

## MILITARY COTS EMI FILTER

<b>-500 to +500V</b> Input	<b>4A</b> Output Current	<b>180mΩ @ 100°C</b> Max DC Resistance	<b>&gt;80dB @ 500kHz</b> Differential Attenuation
-------------------------------	-----------------------------	---	--

The Mil-COTS series of EMI filters brings SynQor's field proven technology and manufacturing expertise to the industrial power applications marketplace. SynQor's innovative packaging approach ensures survivability in the most hostile environments. Compatible with the industry standard format, these filters have high differential-mode and common-mode attenuation, low DC resistance, and a stabilizing bulk capacitor resistor. They follow conservative component derating guidelines and they are designed and manufactured to the highest standards.

## Mil-COTS



Designed and Manufactured in the USA

### Operational Features

- 4A output current
- Very low DC resistance
- >80dB differential-mode attenuation at 500kHz
- >50dB common-mode attenuation at 500kHz
- Stabilizing bulk capacitor and damping resistor included
- All capacitors are X7R multi-layer ceramic

### Mechanical Features

- Size: 1.54" x 2.39" x 0.50" (39.0 x 60.6 x 12.7mm)
- Total weight: 3.53 oz (100 g)

### Safety Features

- 2500V input/output to case isolation
- Certified 60950-1, 2nd Edition
- CE Marked

### In-Line Manufacturing Process

- AS9100 and ISO 9110:200 certified facility
- Full component traceability

### Screening/Qualification

- Qualification consistent with MIL-STD-883
- Available with S-Grade or M-Grade screening
- Pre-cap inspection per IPC-610, Class III
- Temperature cycling per MIL-STD-883, Method 1010, Condition B, 10 cycles
- Burn-In at 100°C baseplate temperature
- Final visual inspection per MIL-STD-2008

### Fundamental Circuit Diagram

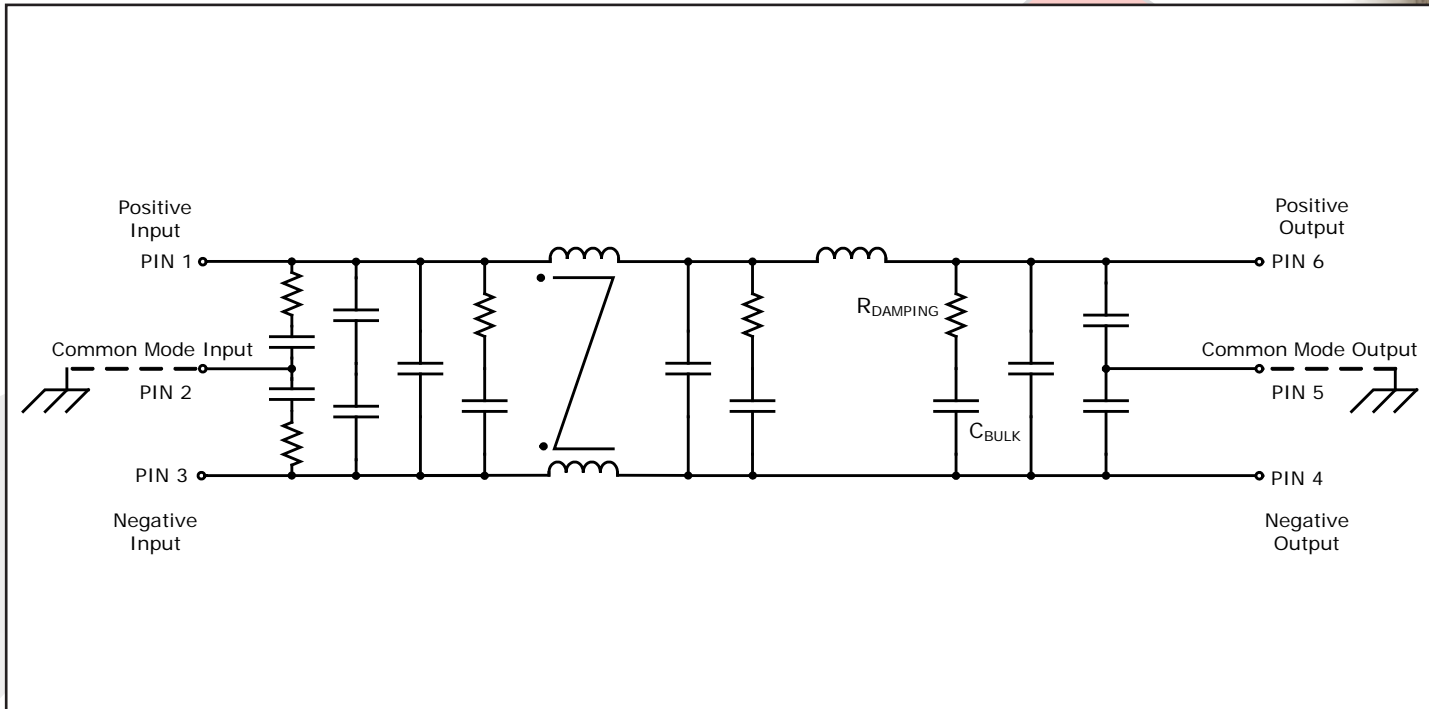

### Typical Connection Diagram

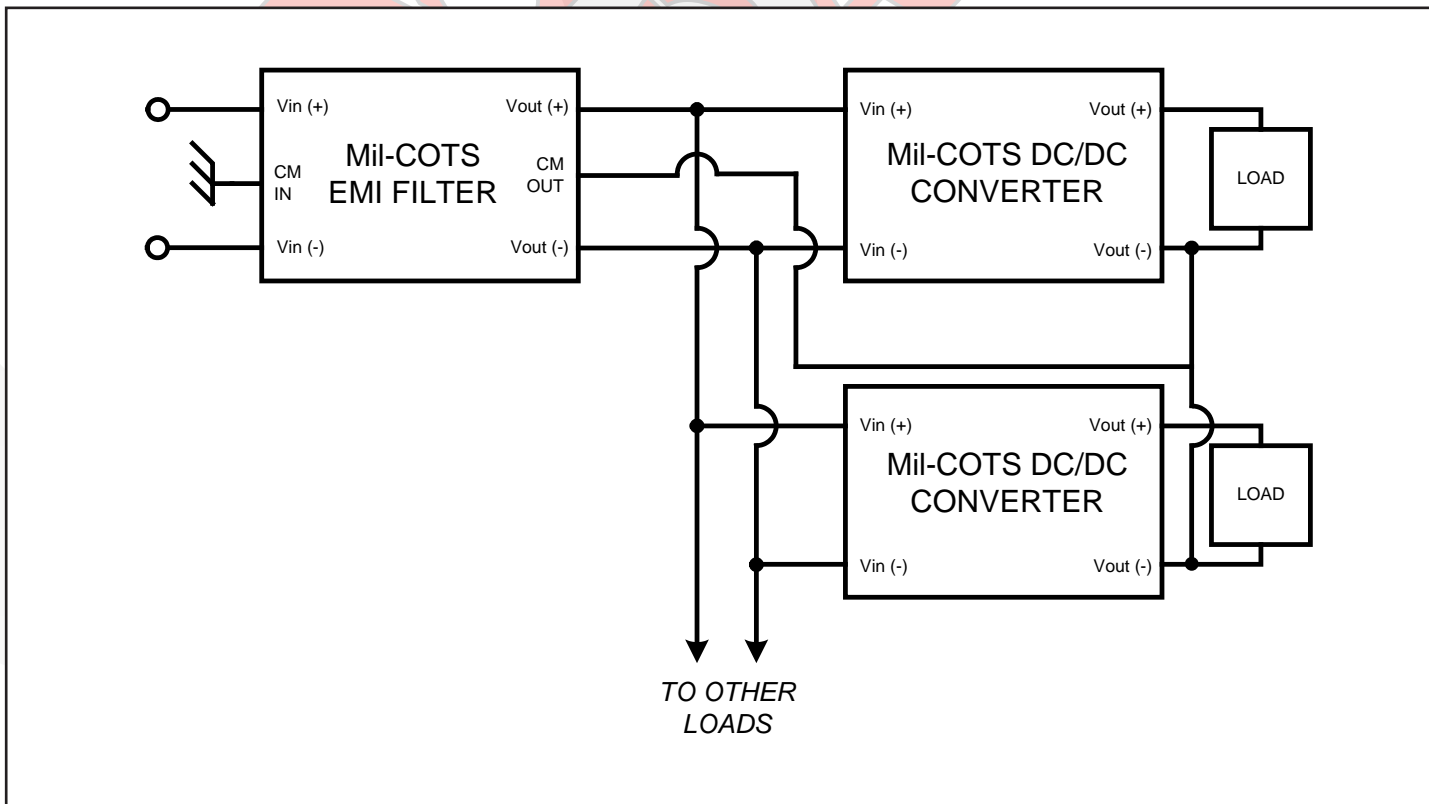



Technical Specification

**MCOTS-F-270-P-QT**

**Current: 4A**

**MCOTS-F-270-P-QT ELECTRICAL CHARACTERISTICS**

|Vin| <= 500V, |Iout| <= 4 A unless otherwise specified

Parameter	Min.	Typ.	Max.	Units	Notes & Conditions
<b>ABSOLUTE MAXIMUM RATINGS</b>					
Input Voltage					
Continuous	-500		500	V	
Transient (≤ 1 s)	-630		630	V	
Isolation Voltage	-2500		2500	V dc	Input/output to common-mode pins
Output Current			4	A	
Operating Case Temperature	-55		100	°C	Baseplate temperature
Storage Case Temperature	-65		135	°C	
Lead Temperature (20 s)			300	°C	
<b>RECOMMENDED OPERATING CONDITIONS</b>					
Input Voltage					
Continuous	-500		500	V	
Transient (≤ 1 s, Rs* = 0Ω)	-630		630	V	* Rs = Source Impedance
Output Current (continuous)	-4		4	A	
<b>ELECTRICAL CHARACTERISTICS</b>					
Output Voltage (continuous)	Vout = Vin - (Iin x Rdc)			V	
DC Resistance Rdc					Total
Tcase = 25°C			146	mΩ	
Tcase = 100°C			180	mΩ	
Power Dissipation					4A output current
Tcase = 25°C			2.33	W	
Tcase = 100°C			2.89	W	
Total Differential-Mode Capacitance		0.544		μF	Measured across input or output pins
Total Common-Mode Capacitance		0.047		μF	Measured between any pin and common-mode pins
Bulk Capacitor		2.44		μF	
Damping Resistor		8.2		Ω	
Noise Attenuation					
Differential-Mode		80		dB	
Common-Mode		50		dB	
Isolation Resistance	100			MΩ	Any pin to common-mode pins
<b>RELIABILITY CHARACTERISTICS</b>					
Calculated MTBF (MIL-STD-217F2)					
GB @ Tcase = 70°C		10		10 <sup>6</sup> Hrs.	
GM @ Tcase = 70°C		0.5		10 <sup>6</sup> Hrs.	
Demonstrated MTBF		TBD		10 <sup>6</sup> Hrs.	See our website for details
<b>WEIGHT CHARACTERISTICS</b>					
Device Weight		100		g	

## Basic Operation and Features

This module is a multi-stage differential-mode and common-mode passive EMI filter designed to interface a power source with one or more Mil-COTS dc-dc converters (or other loads that create EMI). Each stage of this filter is well damped to avoid resonances and oscillations, and only X7R multi-layer ceramic capacitors are used. This Mil-COTS EMI filter includes a large bulk capacitor with a series damping resistor to correct for the unstabilizing effect of a converter's negative input resistance. A white paper discussing this negative input resistance and the need for corrective damping can be found on the SynQor website (see Input System Instability application note).

A typical application would place the Mil-COTS filter close to the input of the dc-dc converter. The Input common-mode pin would be connected to the chassis ground that is common with the system input line filter or other earthed point used for EMI measurement. The output common-mode pin would be connected to the output ground or plane of the power converters with as low inductance a path as possible. There are no connections to the metal baseplate, which may also be connected to the chassis ground if desired.

Do not connect the outputs of multiple Mil-COTS filters in parallel. Connecting filters in this manner may result in slightly unequal currents to flow in the positive and return paths of each filter. These unequal currents may cause the internal common-mode chokes to saturate and thus cause degraded common-mode rejection performance.

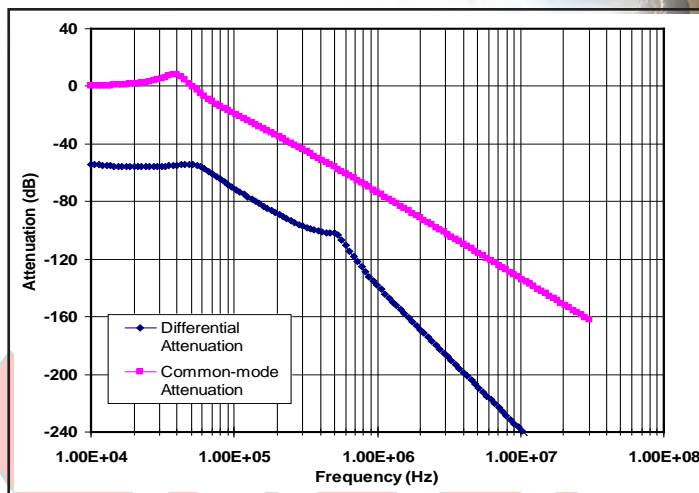
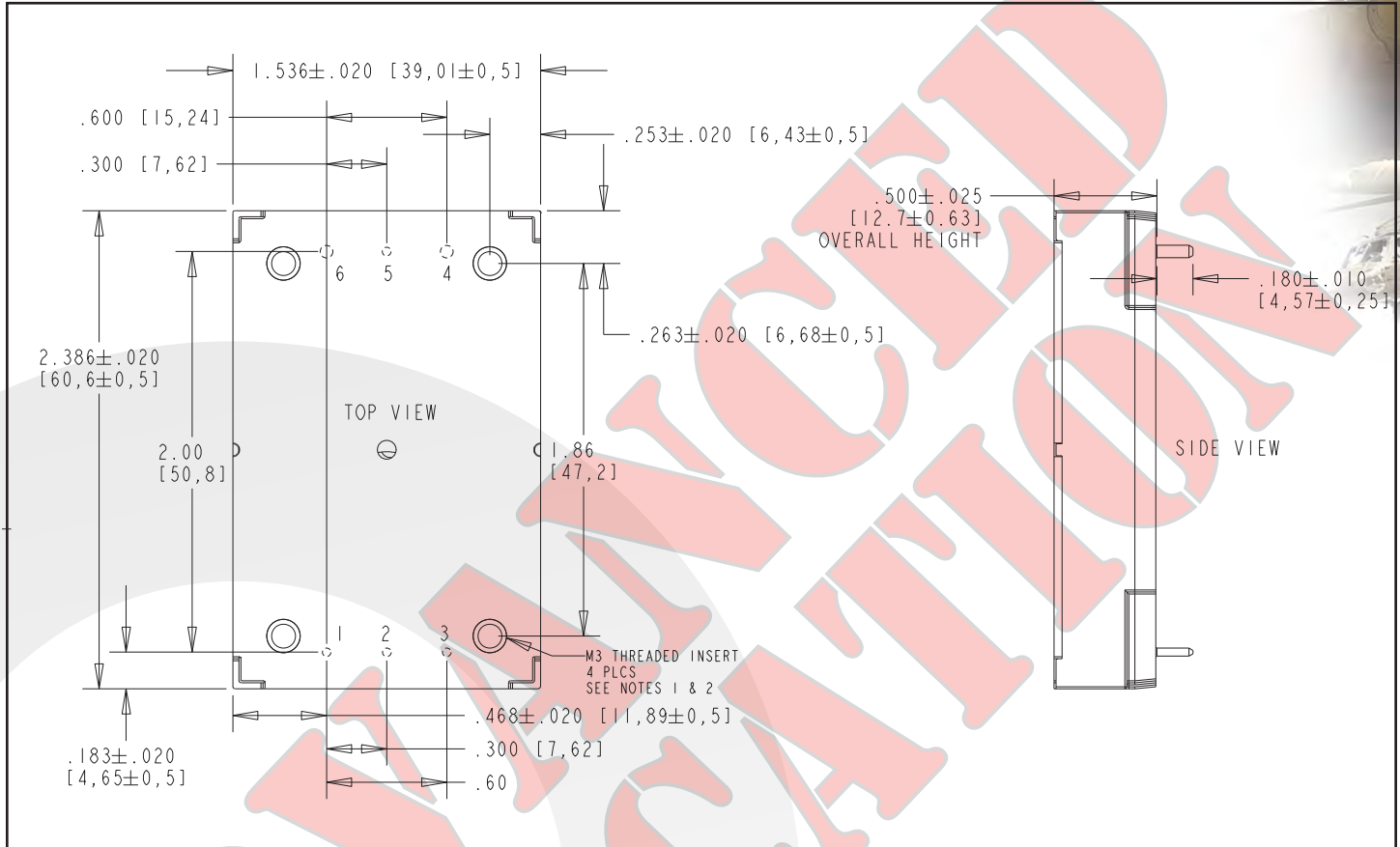

Figure 1: Typical Common Mode and Differential Mode Attenuation provided by the filter as a function of frequency. Both input lines are connected to chassis ground through 50Ω resistors.

### MECHANICAL DRAWING



### NOTES

- Pins 1-3 & 5 are 0.040" (1.02 mm) diameter with 0.080" (2.03 mm) diameter standoff shoulders.
- Pins 4 & 6 are 0.062" (1.57 mm) diameter with 0.100" (2.54 mm) diameter standoff shoulders.
- Recommended pin length is 0.03" (0.76 mm) greater than the PCB thickness.
- All Pins: Material - Copper alloy  
Finish - Matte tin over nickel plate
- M3 screws used to bolt unit's baseplate to other surfaces such as heatsink must not exceed 0.100" (2.54mm) depth below the surface of the baseplate.
- Applied torque per screw should not exceed 6in-lb. (0.7 Nm).
- Baseplate flatness tolerance is 0.004" (.10 mm) TIR for surface.
- All dimensions in inches (mm)  
Tolerances: x.xx +/-0.02 in. (x.x +/-0.5 mm)  
x.xxx +/-0.010 in. (x.xx +/-0.25 mm)
- Weight: 3.53 oz (100 g) typical
- Workmanship: Meets or exceeds current IPC-A-610 Class II

### PIN DESIGNATIONS

Pin No.	Name	Function
1	Vin (+)	Positive input voltage
2	Com In	Common-mode input
3	Vin (-)	Negative input voltage
4	Vout (-)	Negative output voltage
5	Com Out	Common-mode output
6	Vout (+)	Positive output voltage

### Mechanical Drawing

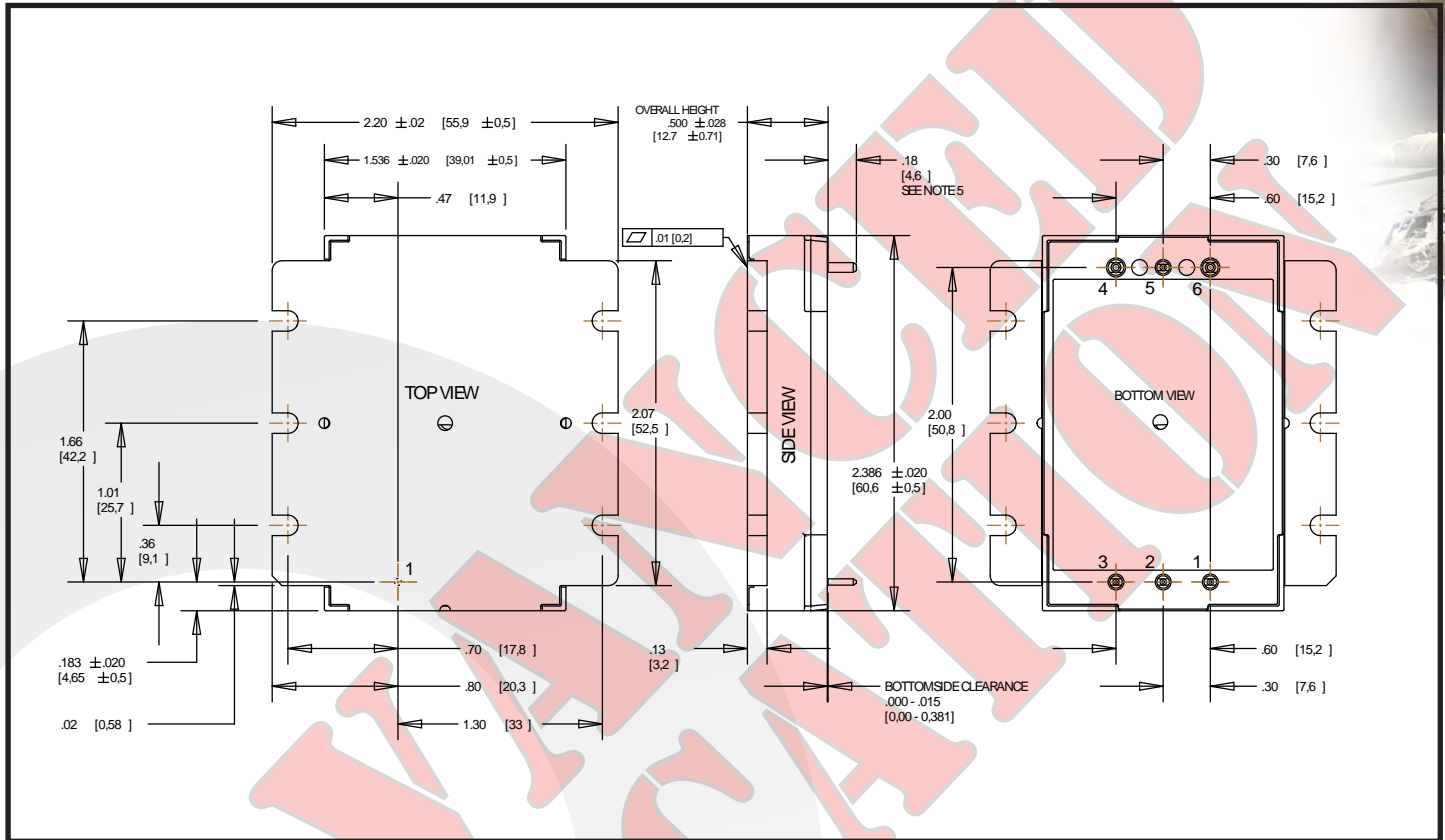

### NOTES

- 1) Use 6 M3 or 4-40 size threaded screws. The screws should be tightened with a torque suitable to get a tight fitting of the converter against the cooling surface.
- 2) Applied torque per screw should not exceed 5in-lb. (3in-lb recommended).
- 3) Baseplate flatness tolerance is 0.004" (.10mm) TIR for surface.
- 4) Pins 1-3 and 5 are 0.040" (1.02mm) diameter, with 0.080" (2.03mm) diameter standoff shoulders.
- 5) Pins 4 and 6 are 0.062" (1.57 mm) diameter with 0.100" (2.54 mm) diameter standoff shoulders.
- 6) All Pins: Material - Copper Alloy- Finish (RoHS 6/6) - Matte Tin over Nickel plate
- 7) Total Weight: 3.53 oz (100 g)
- 8) All dimensions in inches (mm)  
Tolerances: x.xx +/-0.02 in. (x.x +/-0.5mm)  
x.xxx +/-0.010 in. (x.xx +/-0.25mm)
- 9) Workmanship: Meets or exceeds IPC-A-610C Class II
- 10) Recommended pin length is 0.03" (0.76mm) greater than the PCB thickness.
- 11) A thermal interface material is required to assure proper heat transfer from the flanged baseplate to the cooling surface. Thermal grease may be used, or materials such as Thermalloy's Grafoil or Burgquist's HiFlow and Softflow. Other similar products are available from many heatsink manufacturers.

### PIN DESIGNATIONS

Pin No.	Name	Function
1	Vin (+)	Positive input voltage
2	Com In	Common-mode input
3	Vin (-)	Negative input voltage
4	Vout (-)	Negative output voltage
5	Com Out	Common-mode output
6	Vout (+)	Positive output voltage

### Mil-COTS Qualification

Test Name	Details	#Tested (# Failed)	Consistent with MIL-STD-883F Method	Consistent with MIL-STD-883F Method 5005
Life Testing	Visual, mechanical and electrical testing before, during and after 1000 hour burn-in @ full load	15 (0)	Method 1005.8	
Shock-Vibration	Visual, mechanical and electrical testing before, during and after shock and vibration tests	5 (0)		MIL-STD-202, Methods 201A & 213A
Humidity	+85°C, 85% RH, 1000 hours, 2 minutes on/6 hours off	8 (0)	Method 1004.7	
Temperature Cycling	500 cycles of -55°C to +100°C (30 minute dwell at each temperature)	10 (0)	Method 1010.8	Condition A
Solderability	15 pins	15 (0)	Method 2003	
DMT	-65°C to +110°C across full line and load specifications in 5°C steps	7 (0)		
Altitude	70,000 feet (21km) see Note	2 (0)		

Note: A conductive cooling design is generally needed for high altitude applications because of naturally poor convective cooling at rare atmospheres.

### Mil-COTS Screening

Screening	Process Description	S-Grade	M-Grade
Baseplate Operating Temperature		-55°C to +100°C	-55°C to +100°C
Storage Temperature		-65°C to +135°C	-65°C to +135°C
Pre-Cap Inspection	IPC-610, Class III	●	●
Temperature Cycling	Method 1010, Condition B, 10 Cycles		●
Burn-In	100°C Baseplate	12 Hours	96 Hours
Final Electrical Test	100%	25°C	-55°C, +25°C, +100°C
Final Visual Inspection	MIL-STD-2008	●	●

### STANDARDS COMPLIANCE

Parameter	Notes & Conditions
<b>STANDARDS COMPLIANCE</b>	
UL 60950-1 2nd Ed, 2007	
CAN/CSA-C22.2 No. 60950-1:2007	
EN60950-1 Ed 2.0	
CE Marked	2006/95/EC Low Voltage Directive
IEC 61000-4-2	ESD test, 8 kV - NP, 15 kV air - NP (Normal Performance)

Note: An external input fuse must always be used to meet these safety requirements. Contact SynQor for official safety certificates on new releases or download from the SynQor website.



# Technical Specification

**MCOTS-F-270-P-QT**

**Current: 4A**

## Ordering Information/ Part Numbering

Family	Product	Input Voltage	Filter Type	Package	Heatsink Option	Screening Level
MCOTS	F: Filter	28: -40V to +40V 48: -80V to +80V 270: -500V to +500V	P: Passive	QT: Quarter Brick	N: Normal Threaded F: Flanged	S: S-Grade M: M-Grade

Example MCOTS-F-270-P-QT-N-S

Not all combinations make valid part numbers, please contact SynQor for availability. See the Product Summary web page for more options.

### Application Notes

A variety of application notes and technical white papers can be downloaded in pdf format from our website.

### PATENTS

SynQor holds the following U.S. patents, one or more of which apply to this product: Additional patent applications may be pending or filed in the future.

5,999,417	6,222,742	6,545,890	6,577,109
6,594,159	6,731,520	6,894,468	6,896,526
6,927,987	7,050,309	7,072,190	7,085,146
7,119,524	7,269,034	7,272,021	7,272,023
7,558,083	7,564,702		

### Contact SynQor for further information:

**Phone:** 978-849-0600  
**Toll Free:** 888-567-9596  
**Fax:** 978-849-0602  
**E-mail:** [mqnbofae@synqor.com](mailto:mqnbofae@synqor.com)  
**Web:** [www.synqor.com](http://www.synqor.com)  
**Address:** 155 Swanson Road  
 Boxborough, MA 01719  
 USA

#### Warranty

SynQor offers a two (2) year limited warranty. Complete warranty information is listed on our website or is available upon request from SynQor.

Information furnished by SynQor is believed to be accurate and reliable. However, no responsibility is assumed by SynQor for its use, nor for any infringements of patents or other rights of third parties which may result from its use. No license is granted by implication or otherwise under any patent or patent rights of SynQor.