

High Efficiency, Isolated DC/DC Converter, with Baseplate

This technical addendum contains additional specifications for the baseplated version of the PowerQor Peta half-brick series of converters. This unit is manufactured by adding an industry standard size baseplate to the non-baseplated half-brick converter using standard mounting techniques. The baseplated version allows for optional heatsinking in severe thermal environments or for mounting to a cold plate. Please refer to the HP Axx specification sheets for all specifications that are not included in this addendum.

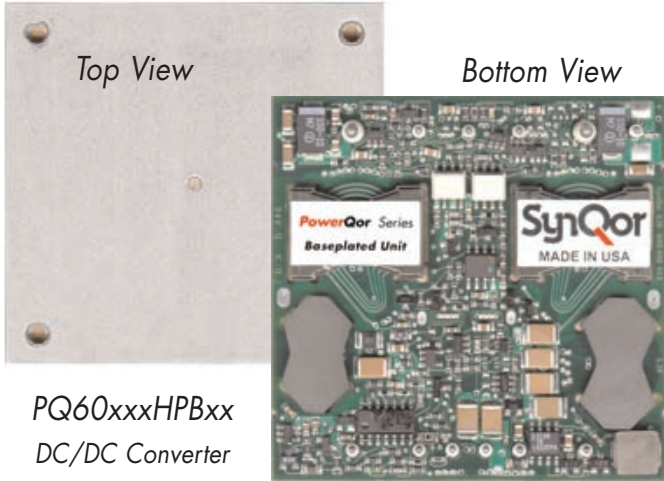

PQ60xxxHPBxx
DC/DC Converter

MECHANICAL LAYOUT

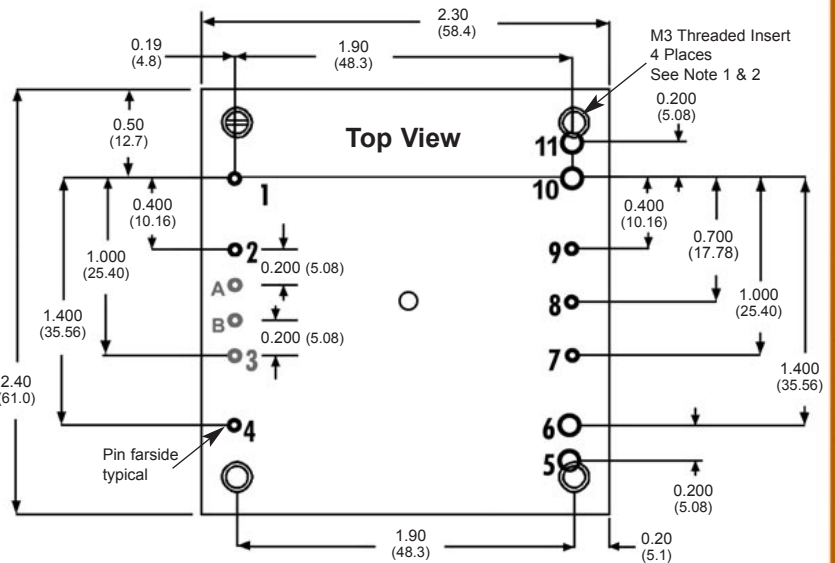
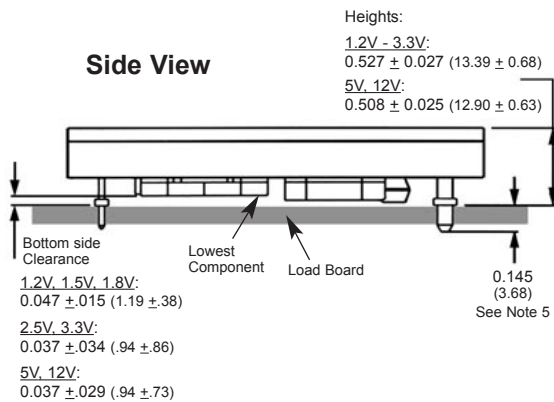

Pins A, B and 3 are optional and only included in full feature versions of the 1.2V - 1.8V modules. Pins 5 and 11 are only included in 3.3V or lower units.

NOTES

- M3 screws used to bolt unit's baseplate to other surfaces (such as heatsink) must not exceed 0.125" (3.18 mm) depth below the surface of the baseplate
- Applied torque per screw should not exceed 3in-lb. (0.33 Nm).
- Baseplate flatness tolerance is 0.004" (.10mm) TIR for surface
- Pins 3, A & B only included in full-feature models (1.2V-1.8V)
- Other pin extension lengths available
- Pins 1-4, 7-9, A, B are 0.040" (1.02mm) diameter with 0.080" (2.03mm) diameter standoff shoulders
- Pins 5, 6, 10, 11 are 0.080" (2.03mm) diameter with 0.125" (3.18mm) diameter standoff shoulders
- Undimensioned components shown are for visual reference only.
- All Pins: Material = copper alloy, Finish = gold over nickel plate
- All dimensions in inches (mm)
- Tolerances: x.xx +/-0.02 in. (x.x +/-0.5mm)
x.xxx +/-0.010 in. (x.xx +/-0.25mm)
- Workmanship: Meets or exceeds IPC-A-610C Class II

SPECIFICATIONS (that differ from HP Axx specs)

Weight: 4.3 oz. (123 g)

Maximum Baseplate Temperature Limit: 100°C

All other specifications are identical to non-baseplated PowerQor converters of equivalent input voltage, output voltage and output current.

ATTACHING HEATSINKS

Follow the guidelines given below when attaching a heatsink to a PowerQor converter with baseplate.

1) A thermal interface material is required to assure proper heat transfer from the baseplate to the heatsink. Thermal grease may be used, or materials such as Thermalloy's Grafoil or Bergquist's HiFlow and SoftFace. Other similar products are available from many heatsink manufacturers.

2) Use four M3 threaded machine screws for attachment. The length of the screw will depend on the thickness of the heatsink baseplate. The maximum permissible screw length below the top surface of the baseplate is not to exceed 3.18mm (0.125") in order to prevent damage to any internal components. A recommended minimum screw length to ensure sufficient hold to the baseplate is 2.54mm (0.10").

3) The screws should be tightened with a torque suitable to get a tight fitting of the heatsink against the thermal interface material and the baseplate. The applied torque per screw should not exceed 3 in-lb (0.33 Nm).

Contact SynQor technical support for additional information.

Patents: SynQor is protected under various patents, including but not limited to U.S. Patent numbers 5,999,417; 6,222,742 B1; 6,594,159 B2; 6,545,890 B2.

PART NUMBERING SYSTEM

The part numbering system for SynQor's PowerQor DC/DC converters follows the format shown in the example below. For a complete listing of available part numbers, please refer to the SynQor web site.

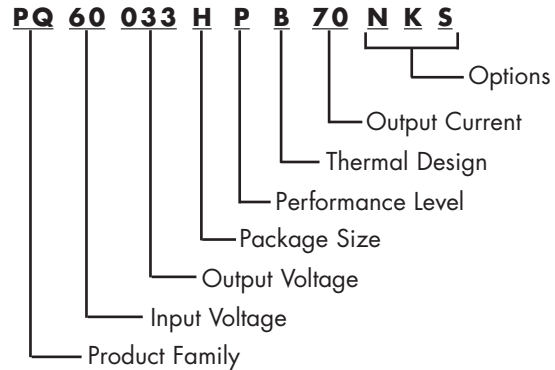

The first 12 characters comprise the base part number and the last 3 characters indicate available options.

Selected PowerQor modules are available with a baseplate. Before ordering baseplated modules, one should consult the factory to ensure that the specific product is available in a baseplated version. The half-brick family of single output converters that have a baseplate should be designated with the letter "B" as the 10th character in the full 15 character part number. The other characters in the part number would follow the same format as a non-baseplated unit to indicate the desired input and output voltage, package size, performance level, rated current, enable logic, pin length and feature set.

When ordering SynQor converters, please ensure that you use the complete 15 character part number.

Contact SynQor for further information:

Phone: 978-849-0600
Toll Free: 888-567-9596
Fax: 978-849-0602
E-mail: sales@synqor.com
Web: www.synqor.com
Address: 155 Swanson Road
Boxborough, MA 01719

Warranty

SynQor offers a three (3) year limited warranty. Complete warranty information is listed on our web site or is available upon request from SynQor.

Information furnished by SynQor is believed to be accurate and reliable. However, no responsibility is assumed by SynQor for its use, nor for any infringements of patents or other rights of third parties which may result from its use. No license is granted by implication or otherwise under any patent or patent rights of SynQor.