

MILITARY FIELD-GRADE 3Φ - 1Φ AC CHANGER

115V L-N 3Φ or 270 Vdc Input	Single-Phase 4000 W / 5000 VA Output	Surge-Rated for 5250 W / 6500 VA Transient (15 s)	115 Vrms L-N, 230 Vrms L-N 50 Hz, 60 Hz, or 400 Hz Output Options	90% Full Load Efficiency
---	---	--	--	---

Sealed Construction, Ultra Low Weight, Compact Size



DESIGNED & MANUFACTURED IN USA

SynQor's Military Field-Grade AC Phase/Frequency Changer units are designed for the extreme environmental and demanding electrical conditions of Military/Aerospace applications. SynQor's MAC incorporates field proven high efficiency designs and rugged packaging technologies. This MAC will accept a 3-Phase AC input, or 270 Vdc input, and change it to a well-conditioned Single-Phase AC output using a two-stage DC link isolated topology. This makes the MAC an ideal solution for both AC and DC sources defined by MIL-STD-704. Options include a selection of output voltage amplitudes, frequencies and an electronic breaker on the AC output to permit fault-tolerant parallel operation for higher power and/or N+M redundant systems.

N+M REDUNDANCY
(optional)

Combine Units for Higher Power, Voltage, 3-Phase AC Output, and/or Redundancy

Features

- Sealed, weather-proof, shock-proof construction
- Two-stage, DC link isolated topology
- 4000 W (5000 VA) output power; 15 s transient to 5250 W (6500 VA)
- Full power operation: -40 °C to +55 °C
- 3-Phase 85-147 Vrms L-N Δ input (draws balanced currents)
- DC 180 - 297 Vdc input
- 0-800 Hz input frequency range
- Pure sinusoidal AC output voltage
- Handles 0.0–1.0 power factor loads and non-linear loads
- Up to 32 units can be combined for higher power, higher voltage, or a 3-Phase AC output
- Capable of N+M redundancy with optional "AC Output Electronic Breaker" (R option) and the appropriate configuration cable
- User I/O and Configuration signal ports
- Battle Mode for over-temperature events
- 1U high rack mount unit (17.00"W x 22.42"D x 1.73"H)
- Low weight: 33 lbs.

Specification Compliance

MAC-4000 units are designed to meet:

- MIL-STD-704 (A-F)
- MIL-STD-1399-300B - Interface Std for Shipboard Systems
- MIL-STD-810G - Environmental Engineering Considerations
- MIL-STD-461F - Electromagnetic Interface

In-Line Manufacturing Process

- AS9100 and ISO 9001 certified facility
- Full component traceability

Options

- 115 Vrms or 230 Vrms AC output
- 50 Hz, 60 Hz, or 400 Hz AC output (software selectable)
- Shipboard version with floating output neutral wire
- N+1 Redundancy

Contents

Technical Specification	2
Block Diagram	4
Application Section	5
Mechanical Features	8
Accessory Options	10
Ordering Information	11

ABSOLUTE MAXIMUM RATINGS

Maximum Input Voltage (2 Minute Excursion)	160 Vrms L-N
	400 Vdc
Line Frequency	800 Hz

AC INPUT OPERATING CHARACTERISTICS

Voltage	3-Phase, 85-147 Vrms L-N
Frequency	DC to 800 Hz
Input Current Total Harmonic Distortion	<2% (4000 W load, 400Hz)
Input Power Factor (Distortion Component)	>0.99 (4000 W load, 60 Hz)
	>0.98 (4000 W load, 400Hz)
Input Current Balance (Highest - Lowest)	<2%
Max. Input Current Per Phase	18 Arms (5250 W load)

DC INPUT OPERATING CHARACTERISTICS

DC Input Voltage - Steady State	180 - 297 Vdc
DC Input Voltage - Transient 1 s	381 Vdc
Maximum Input Current	26 A
Internal DC Fuse Rating	40 A

AC OUTPUT CHARACTERISTICS

Continuous Output Power	4000 W (5000 VA)
Transient Output Power (15 seconds)	5250 W (6500 VA)
AC Output Waveform	Pure Sinusoidal
Voltage Line-Neutral	115 Vrms ± 3%
	230 Vrms ± 3%
Frequency (software selectable)	60 Hz ± 0.5%
	50 Hz ± 0.5%
	400 Hz ± 0.5%
Output Voltage Total Harmonic Distortion	<2%
Load Power Factor	0-1.0 (leading or lagging)
Efficiency	90% (4000 W load)
	88% (2000 W load)

Single-Phase Output

Steady State Load Current	43.5 Arms (115 Vrms)
	21.7 Arms (230 Vrms)
Transient Load Current (15 seconds)	56.5 Arms (115 Vrms)
	28.3 Arms (230 Vrms)
Peak Load Current (Min. Shutdown Threshold)	104 Apk (115 Vrms)
	52 Apk (230 Vrms)

Specifications subject to change without notice.

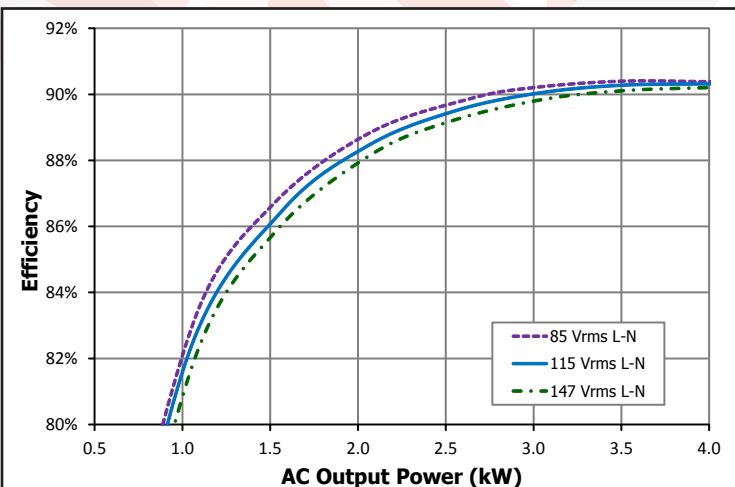

ENVIRONMENTAL CHARACTERISTICS MIL-STD-810G

Temperature Methods 501.5, 502.5

Operating Ambient Temperature	
Full Rated Power	-40 °C to +55 °C
Reduced Power	+55 °C to +70 °C
Storage Temperature	-40 °C to +70 °C

Altitude Method 500.5

Operating	0 - 18,000 ft
Non-operating	0 - 40,000 ft

Environmental Tests

Shock/Drop	Method 516.6, Procedures 1, 4, 6
Temperature Shock	Method 503.5, Procedure 1
Vibration	Method 514.6, CAT 5, 7, 8, 9, 24
Fungus	Method 508.6
Salt Fog	Method 509.5
Sand and Dust	Method 510.5, Procedures 1, 2
Rain	Method 506.5 Procedure 1
Humidity	Method 507.5 Procedure 2
Mechanical Vibrations of Shipboard Equipment	Method 528 Procedure 1

RELIABILITY CHARACTERISTICS MIL-HDBK-217F

MTBF: 450 kHrs	MIL-217F Ground Benign, Ta=25 °C
----------------	----------------------------------

INTERFACE STD FOR SHIPBOARD SYSTEMS MIL-STD-1399B

Type I 115 V L-N 3-Phase Input Power	
Type I 115 V 1-Phase Output Power	
(Order F / R Option to Float Output)	

ELECTROMAGNETIC CAPABILITY MIL-STD-461F

CE101-2	30 Hz - 10 kHz
CE102	10 kHz - 10 MHz
CS101	30 Hz - 150 kHz
CS106	Pulse Transients
CS114 (Curve #5)	10 kHz - 200 MHz
CS115	Impulse Excitation
CS116	10 kHz - 100 MHz
RE101 (Navy Limit)	30 Hz - 100 kHz
RE102 (Navy Topside Limit)	10 kHz - 1 GHz

MECHANICAL CHARACTERISTICS

Chassis Size	17.00" W x 22.42" D x 1.73" H (1U)
Case Material	Aluminum
Weight	33 lbs.

AC Input Connectors

AC Input Connector	CB2-20-4PHA34-FM
--------------------	------------------

AC Output Connectors

115V Single Phase	CB2-20-19SXS34-FM
230V Single Phase	CB2-20-19SXS34-FM

I/O Ports

Configuration I/O Port	HD DB15 Male
User I/O Port	HD DB15 Female
Ethernet Port	Amphenol RJF22N00, Code B

Cooling Exhaust Fans

Sound Pressure Level (SPL)	64 dB(A)
Air Flow	0.92(m³/min) 32.5 CFM

Two fans in system; above specs are for each fan separately.

High Density DB15 Female (15 Pin Connector)

Signal	PIN	Function
TX	2	RS232 DCE Device Transmit
RX	3	RS232 DCE Device Receive
GND	4, 5	Ground reference for all digital inputs and outputs
BATTLE_MODE	6	TTL-Input*, pull "low" to engage Battle Mode to disable internal over temperature protection, has internal pull-up to +5 V
INPUT_GOOD	7	Open collector* output where "low" indicates Input voltage is within range
+5 V	8	Vout with minimal current drive usable as a pull-up voltage for open collector output signals. Load must be < 35 mA
REMOTE_START	12	Drive this line to +5 V with ≥ 5 mA to enable MAC output
SHUTDOWN	13	Drive this line to +5 V with ≥ 5 mA to disable MAC output
OUT_OK	14	Open collector* output where "low" indicates AC Output voltage is within range
OVER_TEMP	15	Open collector* output where "low" indicates that the MAC is at or above its maximum temperature

*With an internal 50 k Pull-up Resistor to 5 V and ESD Protection Diodes



Safety & Qualifications (Pending)

EN 62368-1

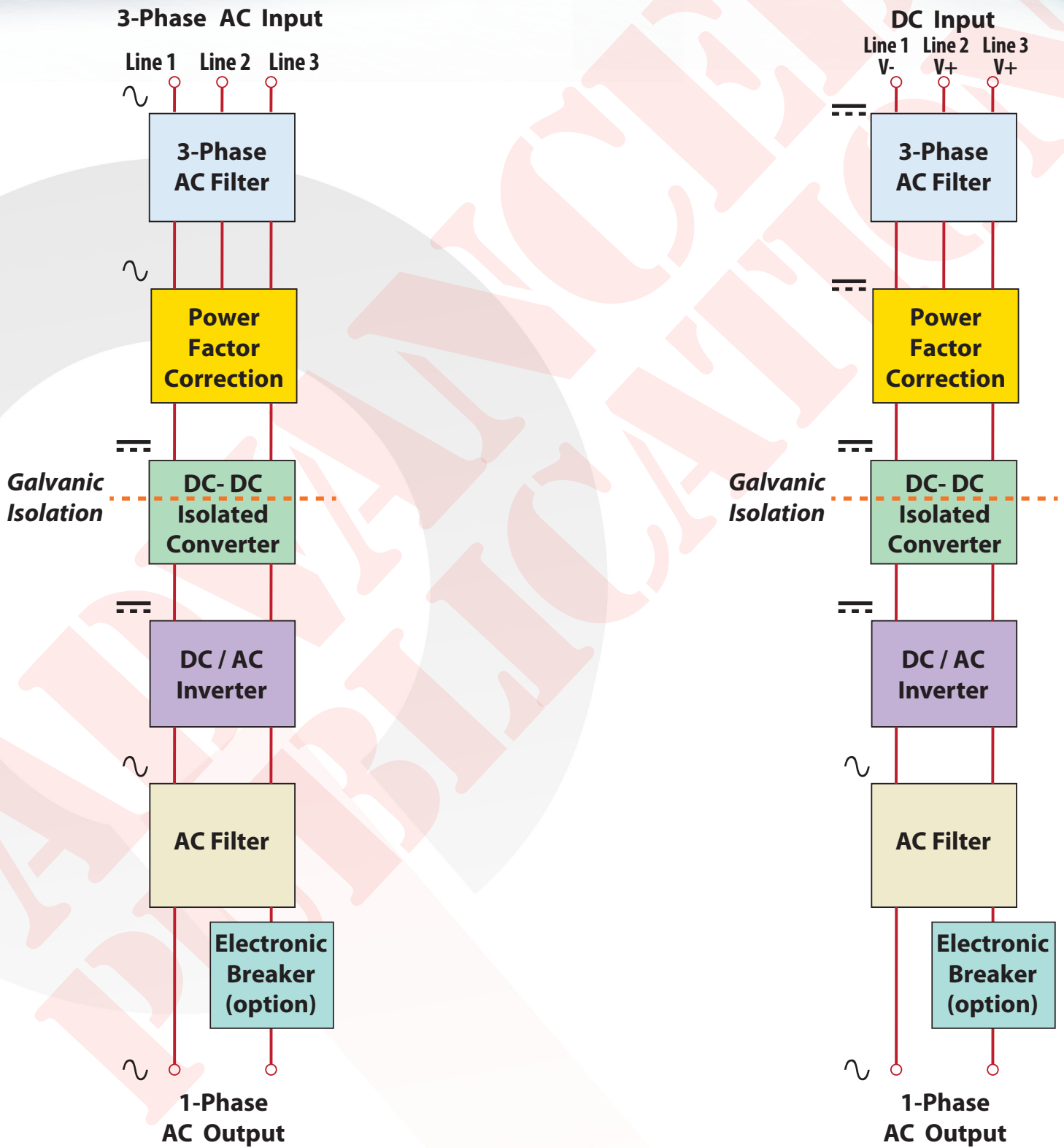

“R” and “F” Options: Paralleling With and Without Redundancy

“F” Option: Expanded Paralleling

With the “F” option, up to 32 MAC units can be placed in parallel. AC output current sharing among the paralleled units is accomplished with a high speed digital configuration cable. The units will share the total load current to within $\pm 2\%$, and for a split-phase or 3-phase system the AC voltages and AC currents will have phase balance within ± 2 degrees.

While up to 32 “F” option units can be placed in parallel, there is no guarantee of redundancy. A failure of any one unit with the “F” option could cause the AC output bus to collapse.

“R” Option: AC Output Electronic Breaker

In addition to paralleling up to 32 units, the “R” option also adds an electronic breaker to the AC output of the MAC to permit fault-tolerant, glitch-free parallel operation. With this option, when several MAC units are connected in parallel at their AC outputs and one unit has an internal fault that might otherwise have pulled down the AC output bus, the electronic breaker will disconnect the failed unit so that the remaining paralleled units can continue to power the bus. This allows the system to be “fault-tolerant”. The disconnect occurs very quickly so that the AC output voltage will remain within its specified parameters as long as the remaining paralleled units can deliver the total load power. This allows the system to continue running “glitch-free”.

The electronic breaker is a single-pole breaker present in the hot-side AC output wire only. The neutral AC output wire is left floating from the MAC chassis to facilitate the paralleling of units into various configurations.

“R” Option: N+M Redundancy

The “R” option makes it possible to set up N+1, or more generally N+M, redundant systems with a total of up to 32 MAC units. In such a system the failure of one unit (or M units) will not cause the overall system to fail. A failed unit can then be replaced to return the redundancy level to its original design. The replacement unit can be inserted into a live, operating system with proper precautions, but for safety reasons it is recommended that the system be turned off first.

Output Power Cable Connection

MAC systems are formed by first connecting the neutral wires of all the individual units together. For single phase systems, the hot wires are also connected together to form a single bank of MAC units. Split-phase systems are formed by connecting the hot output wires into two banks. One bank will have its output voltage phase-shifted 180° from the other. The phase-shift is determined by the configuration cable. Similarly, 3-phase systems are formed by grouping the hot output wires into three banks, each bank having its output voltage phase-shifted by 120° . Again, the phase shift is determined by the configuration cable. Since 3-phase systems are formed by connecting the neutral wires together and phase shifting the hot wires, the AC outputs must be wye-connected to form 3-phase systems. Delta connection of MAC units is not supported. However, once a 3-phase system is formed, loads may be connected as wye or delta.

The diagrams on the following page give examples of how multiple MAC units with the “F” or “R” option can be connected to create higher output power single-phase, split-phase, and 3-phase AC systems. Systems with the “R” option will have N+M redundancy as long as N units are sufficient for the maximum load power per phase. Note, again, that the maximum total number of units that can be arranged in any of these configurations is 32.

Configuration Cables

Any system of “F” or “R” option MAC units requires a specific configuration cable that defines the arrangement of MAC units in the system. The configuration cable determines the phase shift for split-phase and 3-phase systems. The cable also provides high speed digital communication for current sharing on each phase.

Configuration cables for two parallel units and three parallel units in a single-phase system, two unit split-phase systems, and three unit three phase systems are available as standard products. Please contact the factory to purchase configuration cables for systems larger than three MAC units.

Application Figures

Single Phase Output System

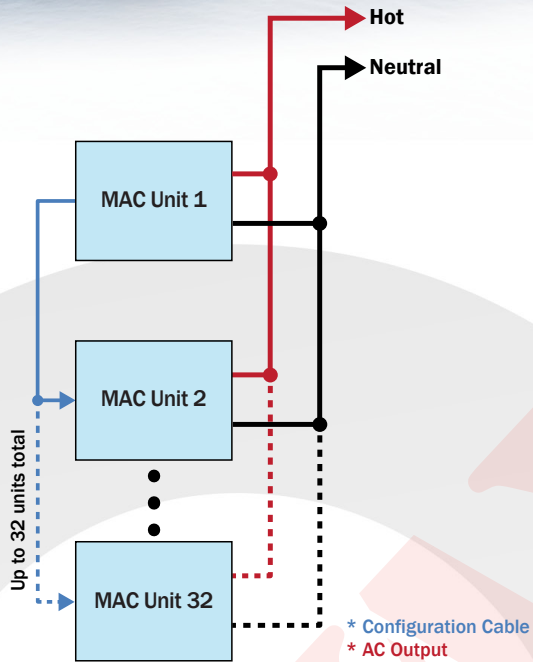

Split Phase Output System

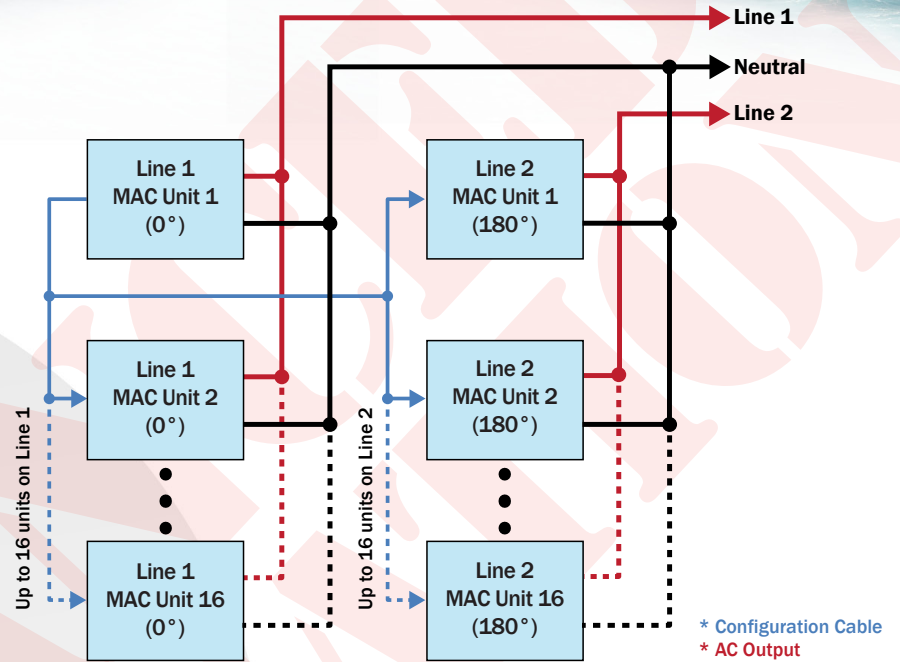

3-Phase Output System (Wye - Connection Only)

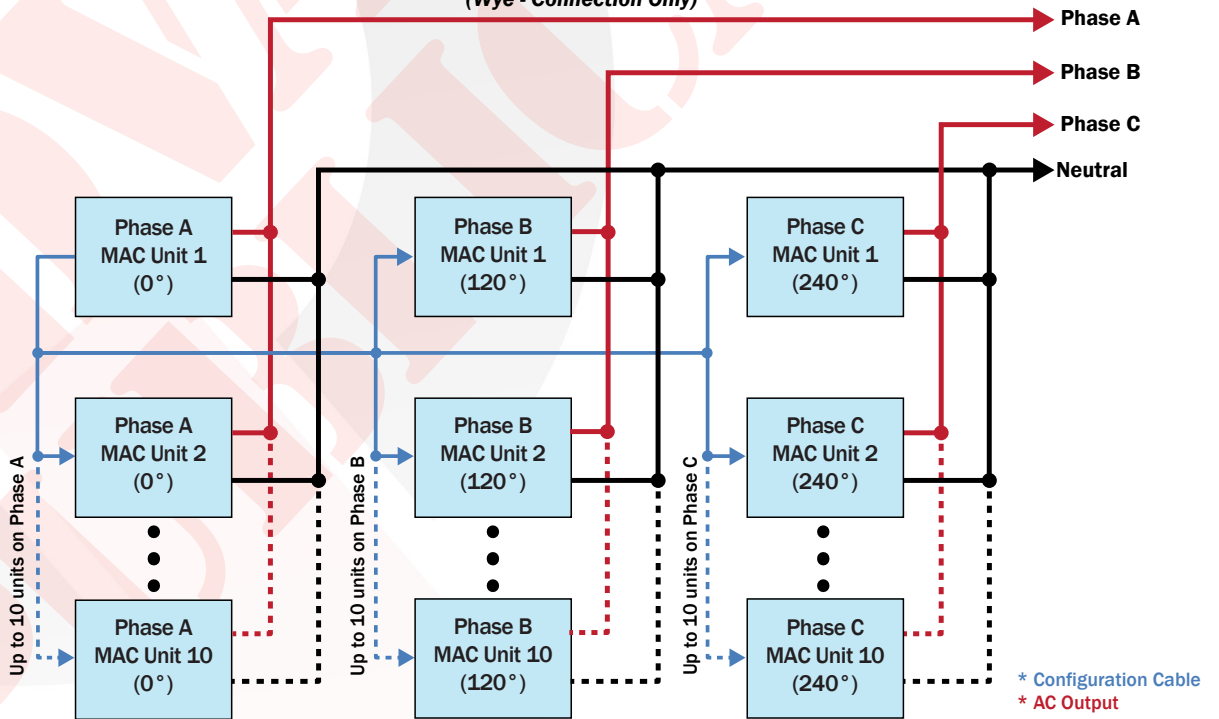

*Contact factory for system specific configuration cables.

The MAC-4000 is designed to accommodate almost all sources as defined by MIL-STD-704. These sources include 115Vac 60Hz, 115Vac 400Hz, and 270Vdc. The only source not supported is 28Vdc. This allows end-use designs to be installed on multiple different platforms without needing to redesign the power section.

The table below shows how to connect the input wires for AC or DC operation.

Pin Number	AC Connection	DC Connection
A	Line 1	DC_IN -
B	Line 2	DC_IN +
C	Line 3	DC_IN +
D	Ground	Ground

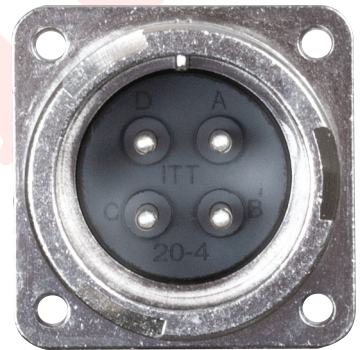
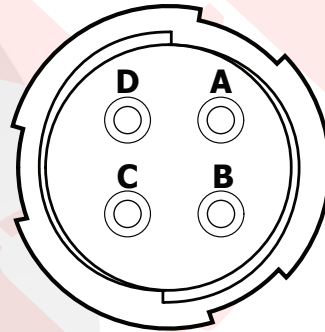

MAC-4000-1U UNIT



MAC-4000-1U UNIT

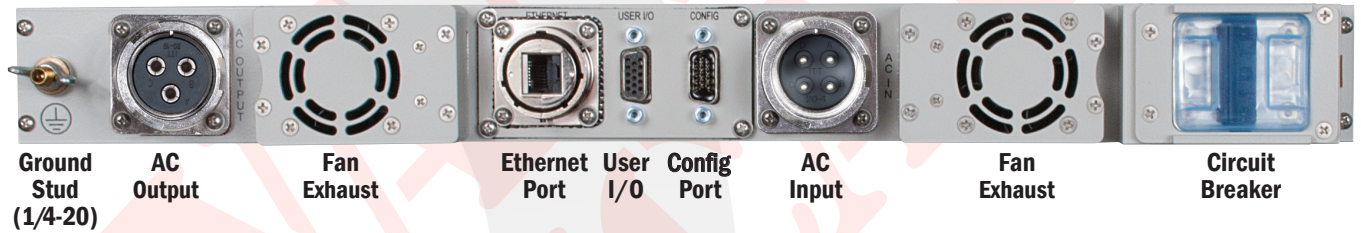

Mechanical Diagram 1U

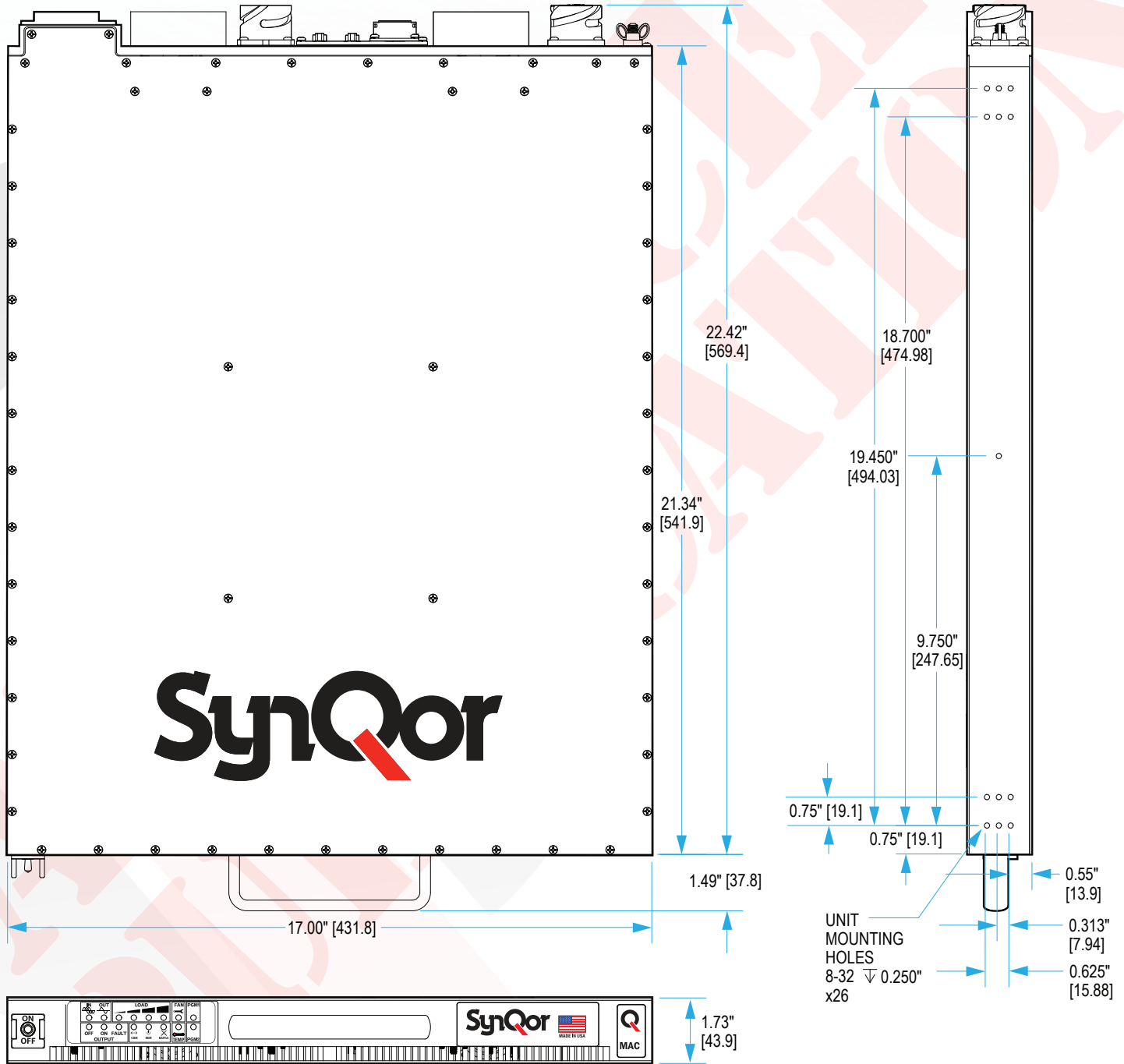

Rail Kits	
Slide Rail Kit ²	SYN-9002
Fixed Bracket Kit ³	SYN-9031
Power Cables (10' long)	
AC Input (Hardwire)	SYN-9118
AC Output (Hardwire)	SYN-9140
Rackmount Transit Cases	
Transit Case, 3U, Gray, with Casters ³	SYN-9410
Transit Case, 3U, Gray, No Casters ³	SYN-9412
Fan Replacement Kit	
Counter-Rotating Replaceable Fan Modules (Pack of 2)	SYN-9452

Notes:

- 1: Other Options also available, check the website or contact power@synqor.com for further information.
- 2: Slide Rail Kit (SYN-9002) is not recommended for transit and ruggedized use.
- 3: Fixed Bracket Kit (SYN-9031) with Transit Case (SYN-9410 or SYN-9412) is required for transit and ruggedized use (qualified to pass MIL-STD-810G Loose Cargo and Transit Drop requirements).

User Communications (I/O) Cables	
HD DB15M to DB9F (RS232, 10')	SYN-9301
HD DB15M to DB15M (RS232 and Digital I/O, 10')	SYN-9305
Mil-Circular to RJ45 (Ethernet, 10')	SYN-9321
Configuration Cables	
HD DB15F to DB15F (2 Units Parallel, 3')	SYN-9341
HD DB15F to DB15F (3 Units Parallel, 6')	SYN-9343
HD DB15F to DB15F (4 Units Parallel 9')	SYN-9344
HD DB15F to DB15F (5 Units Parallel 15')	SYN-9345
HD DB15F to DB15F (2 Units Series, 3')	SYN-9613
HD DB15F to DB15F (3 Units 3 Phase, 6')	SYN-9617



*Optional
Rackmount Transit Case*

Ordering Information

Base Models			
Model Number	Power	Height (W x D x H)	Weight
MAC-4000-1U-	4000 W 5000 VA	1U (17.00" x 22.42" x 1.73")	33 lbs.

Base Models	Options								Options	
	Line to Neutral Input Voltage	Number of Input Phases	Input Freq Range	AC Output Voltage	AC Output Neutral Wire	AC Output Set Point Freq	Output Config	Additional Options	Line to Neutral Input Voltage	Number of Input Phases
MAC-4000-1U-	1	T	W	1 2	G F R	5 6 4	S	-E 00 CE	1 115 Vac L-N / 200 Vac L-L 270 Vdc	T 3-Phase
									W 0 - 800 Hz	
									1 115 V 2 230 V	
									G Grounded F Floating* R AC Output Electronic Breaker*	
									5 50 Hz 6 60 Hz 4 400 Hz	
									S One Single-Phase Output	
									-E Ethernet/SNMP with Config Loading	
									00 No CE Marking CE CE Marking	

Not all combinations make valid part numbers, please contact SynQor for availability. See the Product Summary web page for more options.

*Notes:

Order "F: Floating" option when configuring the AC output for multi-unit combinations of up to 32 units.

Order "R: AC Output Electronic Breaker" option for fault-tolerant, glitch-free parallel systems of up to 32 units with N+M redundancy. The AC output neutral wire will not be connected to the chassis for either the F option or R option.

Example:

MAC-4000-1U-1TW2G6S-E00

Contact SynQor for further information and to order:

Phone: 978-849-0600 Fax: 978-849-0602

E-mail: power@synqor.com Web: www.synqor.com

Address: 155 Swanson Road, Boxborough, MA 01719 USA

WARRANTY

SynQor offers a one (1) year limited warranty. Complete warranty information is listed on our website or is available upon request from SynQor.

PATENTS

SynQor holds numerous U.S. patents, one or more of which apply to most of its power conversion products. Any that apply to the product(s) listed in this document are identified by markings on the product(s) or on internal components of the product(s) in accordance with U.S. patent laws. SynQor's patents include the following:

7,765,687 7,787,261
8,149,597 8,644,027