



Military COTS 3-Phase AC Line Filter

85 to 140 Vrms (L-N) Input Voltage	6 Arms Output Current	2.0 kW @ 115 Vrms (L-N) Output Power	145 mΩ @ 100°C Max Resistance per Phase	55 dB @ 200 kHz Diff. Mode Attenuation (at 4.5 Arms per Phase)
--	--	--	--	---

Full Power Operation: -55 °C to +100 °C

*Mil*COTS™

This MilCOTS 3-phase EMI Line Filter is an essential building block of an AC-DC power supply. It is designed to be used in front of each of multiple SynQor MPFC-115-3PH-270P-FP 3-phase PFC modules in a paralleled application. This filter provides high differential-mode attenuation, but does not contain any common-mode filtering. Separate external common-mode filtering is required to meet MIL-STD-461 EMI requirements. This module is designed to comply with a wide range of military standards and is manufactured in the United States.



MACF-115-3PH-UNVD-QT-N-M

Operational Features

- -55 °C to +100 °C baseplate temperature
- 6 Arms output current
- Very low series resistance
- 55 dB @ 200 kHz diff. mode attenuation (4.5 Arms per phase)
- Meets common EMC standards in properly designed system with SynQor's MPFC module and MCOTS 270 converters

Mechanical Features

- Standard Size: 2.39" x 1.54" x 0.50" (60.6 x 39.0 x 12.7 mm)
- Total weight: 3.3 oz (94 g)
- Flanged baseplate version available

In-Line Manufacturing Process

- AS9100 and ISO 9001 certified facility
- Full component traceability

Compliance Features

- MACF Series filters (with MPFC & MCOTS converters) are designed to meet:
- MIL-STD-704 (A-F) w/ leading power factor
 - MIL-STD-461 (C, D, E, F)
 - MIL-STD-1399
 - MIL-STD-810G

Contents

	Page No.
Technical Diagrams	2
Electrical Characteristics	3
Operation and Features	4
Standards & Qualification Testing	5
Encased Mechanical Diagram	6
Flanged Mechanical Diagram	7
Ordering Specifications	8



Technical Diagrams

Fundamental Circuit Diagram

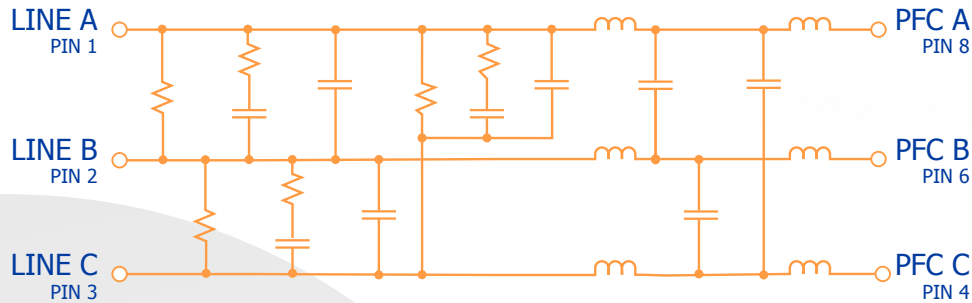

Typical Application Diagram

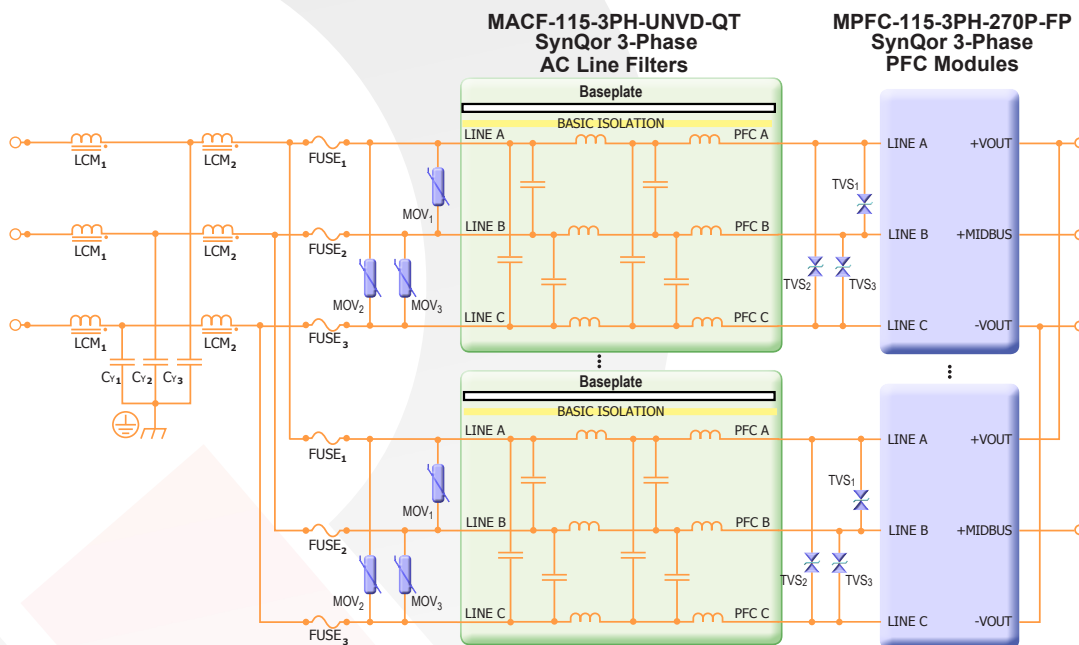

Suggested Parts:

- MOV 1-3 : 300 Vrms, 60 J ; EPCOS S10K300E2
- TVS 1-3 : 430 Vpk, 20 J; Littelfuse AK3-430C or Bourns PTVS-430C-TH
- Fuse 1-3 : 250 Vrms, 10 A; Littelfuse 0216010.XEP
- CY 1-3 : 2 x 4.7 nF = 9.6 nF, X7R, 2220, Y2; Murata GA355DR7GF472KW01L
- LCM 1-2 : For recommended construction see Table 1 in MPFC-115-3PH-270-FP datasheet



MACF-115-3PH-UNVD-QT

Technical Specification

MACF-115-3PH-UNVD-QT Electrical Characteristics

Operating Conditions: Vin = 115 Vrms L-N (199 Vrms L-L) @ 400 Hz; 4.5 Arms per phase; baseplate temperature 25 °C unless otherwise noted. Full operating baseplate temperature is -55 °C to 100 °C. Specifications subject to change without notice.

Parameter	Min.	Typ.	Max.	Units	Notes & Conditions
ABSOLUTE MAXIMUM RATINGS					
Input Voltage					
Operating			200	Vrms L-N	Continuous (346 Vrms L-L)
Operating Transient Protection			900	Vpk L-L	100 ms transient
Isolation Voltage			2150	Vdc	Input/Output to baseplate
Operating Case Temperature	-55		100	°C	Baseplate temperature
Storage Case Temperature	-65		135	°C	
RECOMMENDED OPERATING CONDITIONS					
Input Voltage (Continuous)	85	115	140	Vrms L-N	147 to 242 Vrms L-L
Input Frequency	45		800	Hz	
Output Current Range			6.0	Arms	Per phase
ELECTRICAL CHARACTERISTICS					
Series Resistance Rs					Per phase
Tcase = 25 °C		90		mΩ	
Tcase = 100 °C			145	mΩ	
Total Power Dissipation					
Zero Load, 400 Hz		2.2		W	
Zero Load, 60 Hz		0.5		W	
6 Arms (per phase) @ 400 Hz, Tcase = 25 °C		12		W	
6 Arms (per phase) @ 400 Hz, Tcase = 100 °C			18	W	Guaranteed by design
Differential-Mode Line-Line Capacitance		0.35		μF	Three such capacitors form Δ line network
Internal Resistance (line-line)		1.5		MΩ	Discharges capacitors for safe handling
Reactive Power (per phase)		35		VAR	At 400 Hz; scales with line frequency
Common-Mode Capacitance (per phase)		0		nF	
Differential-Mode Attenuation, 200 kHz		55		dB	At 4.5 Arms per phase, See Figure A
Common-Mode Attenuation, 200 kHz		0		dB	External common mode filter required
Isolation Resistance	100			MΩ	Any pin to PE GND
RELIABILITY CHARACTERISTICS					
Calculated MTBF (MIL-217) MIL-HDBK-217F		99		10 ⁶ Hrs.	Ground Benign, Tb = 70 °C
Calculated MTBF (MIL-217) MIL-HDBK-217F		9.8		10 ⁶ Hrs.	Ground Mobile, Tb = 70 °C
Field Demonstrated MTBF				10 ⁶ Hrs.	See our website for details



BASIC OPERATION AND FEATURES

This MilCOTS AC Line Filter is a multi-stage differential-mode-only passive EMI filter designed to work with a SynQor MPFC-115-3PH-270P-FP MPFCQor 3-Phase PFC module, specifically for paralleled applications.

This filter has no internal common-mode attenuation. As shown in the "Typical Connection Diagram" on page 2, common-mode filtering for direct-paralleled applications should be implemented externally, upstream of where the AC lines branch off to each individual filter/PFC unit.

Common mode filters cannot be paralleled in non-isolated applications because even small imbalances in branch current can result in core saturation. If the output of each PFC module is individually isolated by downstream DC/DC converters before being placed in parallel, then half-brick MACF-115-3PH-UNV-HT filters may be used in lieu of the external common mode stage. The half-brick '-UNV' model integrates both differential-mode and common mode filtering, and individual downstream isolation prevents the filter from experiencing any offset in the sum of line currents.

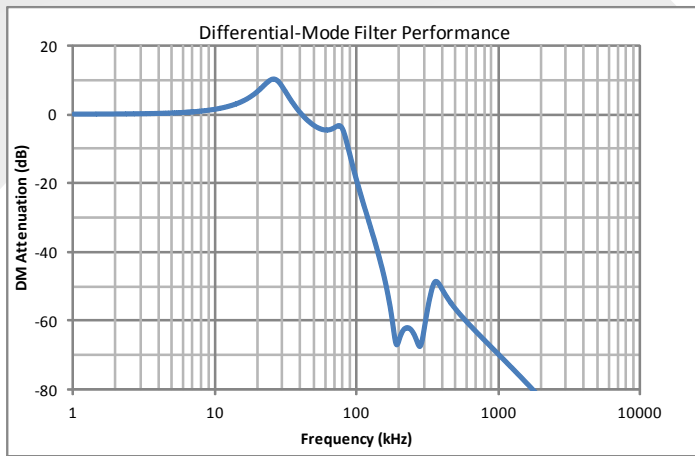
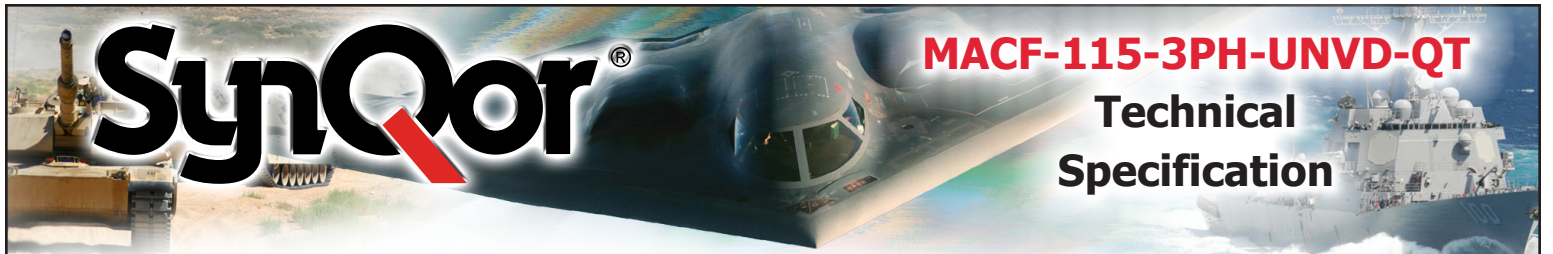

Figure A: Typical Differential-Mode (DM) attenuation as a function of frequency. LISN equivalent resistance is 50Ω.

Figure B:



Standards & Qualification Testing

Mil-COTS MIL-STD-810G Qualification Testing

MIL-STD-810G Test	Method	Description
Fungus	508.6	Table 508.6-I
Altitude	500.5 - Procedure I	Storage: 70,000 ft / 2 hr duration
	500.5 - Procedure II	Operating: 70,000 ft / 2 hr duration; Ambient Temperature
Rapid Decompression	500.5 - Procedure III	Storage: 8,000 ft to 40,000 ft
Acceleration	513.6 - Procedure II	Operating: 15 g
Salt Fog	509.5	Storage
High Temperature	501.5 - Procedure I	Storage: 135 °C / 3 hrs
	501.5 - Procedure II	Operating: 100 °C / 3 hrs
Low Temperature	502.5 - Procedure I	Storage: -65 °C / 4 hrs
	502.5 - Procedure II	Operating: -55 °C / 3 hrs
Temperature Shock	503.5 - Procedure I - C	Storage: -65 °C to 135 °C; 12 cycles
Rain	506.5 - Procedure I	Wind Blown Rain
Immersion	512.5 - Procedure I	Non-Operating
Humidity	507.5 - Procedure II	Aggravated cycle @ 95% RH (Figure 507.5-7 aggravated temp - humidity cycle, 15 cycles)
Random Vibration	514.6 - Procedure I	10 - 2000 Hz, PSD level of 1.5 g ² /Hz (54.6 g _{rms}), duration = 1 hr/axis
Shock	516.6 - Procedure I	20 g peak, 11 ms, Functional Shock (Operating no load) (saw tooth)
	516.6 - Procedure VI	Bench Handling Shock
Sinusoidal vibration	514.6 - Category 14	Rotary wing aircraft - helicopter, 4 hrs/axis, 20 g (sine sweep from 10 - 500 Hz)
Sand and Dust	510.5 - Procedure I	Blowing Dust
	510.5 - Procedure II	Blowing Sand

Mil-COTS Converter and Filter Screening

Screening	Process Description	S-Grade	M-Grade
Baseplate Operating Temperature		-55 °C to +100 °C	-55 °C to +100 °C
Storage Temperature		-65 °C to +135 °C	-65 °C to +135 °C
Pre-Cap Inspection	IPC-A-610, Class III	•	•
Temperature Cycling	MIL-STD-883F, Method 1010, Condition B, 10 Cycles		•
Burn-In	100 °C Baseplate	12 Hours	96 Hours
Final Electrical Test	100%	25 °C	-55 °C, +25 °C, +100 °C
Final Visual Inspection	MIL-STD-883F, Method 2009	•	•



Encased Mechanical Diagram

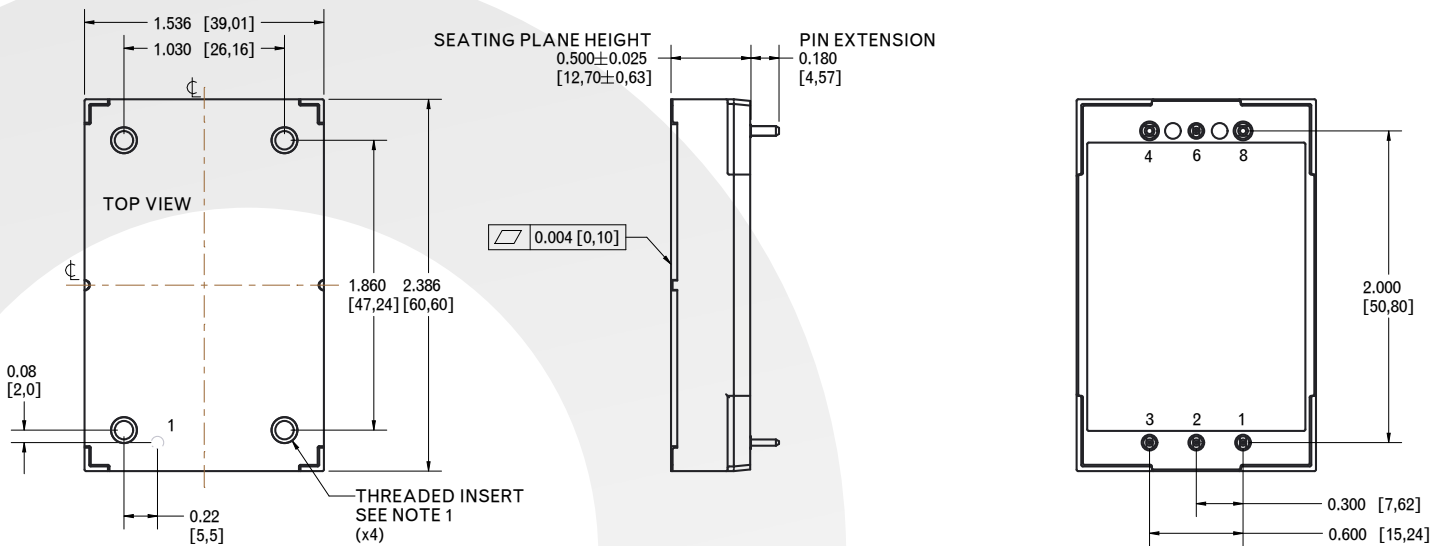

NOTES

- 1) Applied torque per M3 screw is not to exceed 6 in-lb
- 2) Screw is not to exceed 0.100" (2.54mm) below the surface of the baseplate.
- 3) Baseplate flatness tolerance is 0.004" (.10 mm) TIR for surface.
- 4) Pins 1-3, 6 are 0.040" (1.02 mm) diameter with 0.080" (2.03 mm) diameter standoffs.
- 5) Pins 4 and 8 are 0.062" (1.57 mm) diameter with 0.100" (2.54 mm) diameter standoffs.
- 6) All Pins: Material - Copper Alloy
Finish: Matte Tin over Nickel plate
- 7) Total weight: 3.3 oz (94 g)
- 8) All dimensions in inches (mm)
Tolerances: x.xx +/-0.02 in. (x.x +/-0.5 mm)
x.xxx +/-0.010 in. (x.xx +/-0.25 mm)

PIN DESIGNATIONS

Pin	Label	Function
1	LINE A	AC Line Input A
2	LINE B	AC Line Input B
3	LINE C	AC Line Input C
4	PFC C	Filter Output C
6	PFC B	Filter Output B
8	PFC A	Filter Output A



Flanged Mechanical Diagram

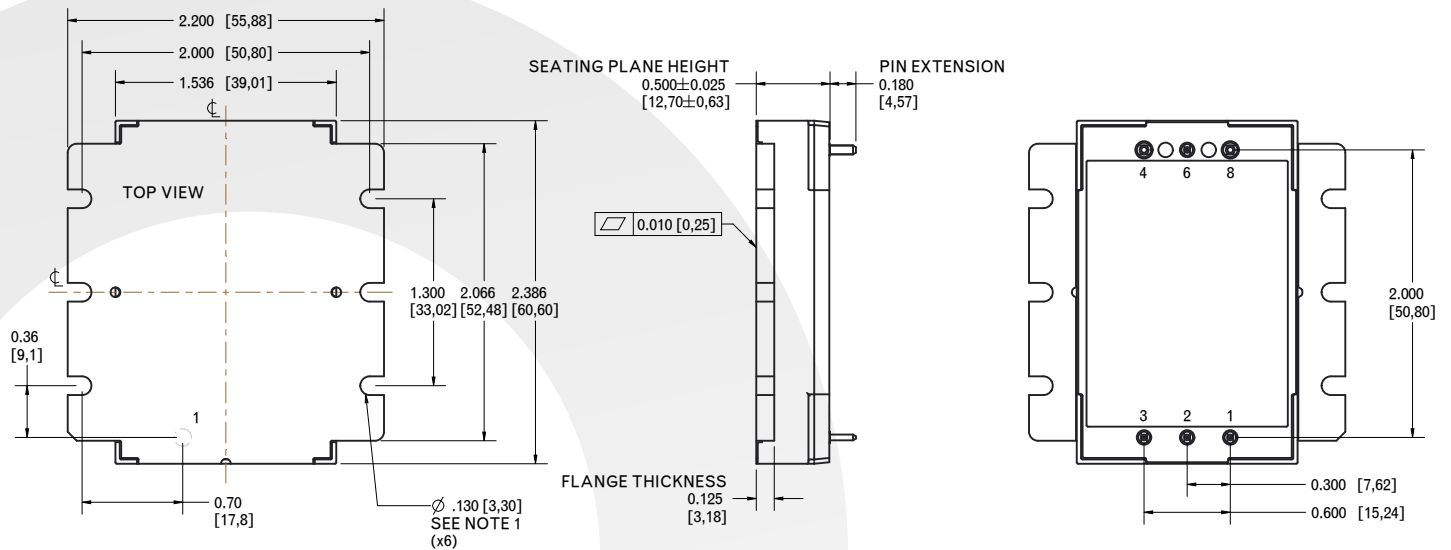

NOTES

- 1) Applied torque per M3 or 4-40 screw is not to exceed 6 in-lb
- 2) Baseplate flatness tolerance is 0.010" (.25 mm) TIR for surface.
- 3) Pins 1-3, 6 are 0.040" (1.02 mm) diameter with 0.080" (2.03 mm) diameter standoffs.
- 4) Pins 4 and 8 are 0.062" (1.57 mm) diameter with 0.100" (2.54 mm) diameter standoffs.
- 5) All Pins: Material - Copper Alloy
Finish: Matte Tin over Nickel plate
- 6) Total weight: 3.5 oz (100 g)
- 7) All dimensions in inches (mm)
Tolerances: x.xx +/-0.02 in. (x.x +/-0.5 mm)
x.xxx +/-0.010 in. (x.xx +/-0.25 mm)

PIN DESIGNATIONS

Pin	Label	Function
1	LINE A	AC Line Input A
2	LINE B	AC Line Input B
3	LINE C	AC Line Input C
4	PFC C	Filter Output C
6	PFC B	Filter Output B
8	PFC A	Filter Output A



MACF-115-3PH-UNVD-QT

Technical Specification

Ordering Specifications

Family	Input Voltage	Phase	Filter Configuration	Package	Thermal Design	Screening Level
MACF	115	3PH	UNVD	QT	N	S
MACF: AC Line Filter	115: 85 to 140 Vrms (L-N)	3PH: 3-Phase	UNVD: 45 - 800 Hz DM-only*	QT: Quarter-Brick Tera	N: Encased Threaded F: Flanged	S: S-Grade M: M-Grade

* This product offers only Differential-Mode filtering. Both DM and CM (Common-Mode) filtering are offered in the half brick MACF-115-3PH-UNV-HT.
 Part Number Example: **MACF-115-3PH-UNVD-QT-N-M**

APPLICATION NOTES

A variety of application notes and technical white papers can be downloaded in pdf format from our [website](#).

ORDERING INFORMATION

Not all combinations make valid part numbers, please contact SynQor for availability.

Contact SynQor for further information and to order:

Phone: 978-849-0600
Toll Free: 888-567-9596
Fax: 978-849-0602
E-mail: power@synqor.com
Web: www.synqor.com
Address: 155 Swanson Road
 Boxborough, MA 01719
 USA

PATENTS

SynQor holds numerous U.S. patents, one or more of which apply to most of its power conversion products. Any that apply to the product(s) listed in this document are identified by markings on the product(s) or on internal components of the product(s) in accordance with U.S. patent laws. SynQor's patents include the following:

6,545,890	6,594,159	6,894,468	6,896,526	6,927,987	7,050,309
7,085,146	7,119,524	7,765,687	7,787,261	8,149,597	8,644,027

WARRANTY

SynQor offers a two (2) year limited warranty. Complete warranty information is listed on our website or is available upon request from SynQor.