

## MILITARY COTS DC-DC CONVERTER

<b>34-75V</b> Continuous Input	<b>34-100V</b> Transient Input	<b>15V</b> Output	<b>3.3A</b> Output	<b>87% @ 1.65A / 87% @ 3.3A</b> Efficiency
-----------------------------------	-----------------------------------	----------------------	-----------------------	---

**Full Power Operation: -55°C to +100°C**

The MilQor® series of Mil-COTS DC-DC converters brings SynQor's field proven high-efficiency synchronous rectification technology to the Military/Aerospace industry. SynQor's ruggedized encased packaging approach ensures survivability in demanding environments. Compatible with the industry standard format, these converters operate at a fixed frequency, and follow conservative component derating guidelines. They are designed and manufactured to comply with a wide range of military standards.

# MilCOTS™



Designed and Manufactured in the USA

### Safety Features

- 2250 V, 30 MΩ input-to-output isolation
- Certified 62368-1 requirement for basic insulation (see Standards and Qualifications page)

### Mechanical Features

- Industry standard sixteenth-brick pin-out configuration
- Size: 1.04" x 1.44" x 0.50" (26.3 x 36.5 x 12.7 mm)
- Total weight: 1.10 oz (31.2 g)
- Flanged baseplate version available

### Control Features

- On/Off control referenced to input return
- Remote sense for the output voltage
- Output voltage trim range of +10%, -10%

### Specification Compliance

MCOTS series converters (with an MCOTS filter) are designed to meet:

- MIL-HDBK-704 (A-F)
- RTCA/DO-160E Section 16
- MIL-STD-1275 (B,D)
- DEF-STAN 61-5 (Part 6)/(5 or 6)
- MIL-STD-461 (C, D, E, F)

### Operational Features

- High efficiency, 87% at full rated load current
- Operating input voltage range: 34-75V
- Fixed frequency switching provides predictable EMI
- No minimum load requirement

### Protection Features

- Input under-voltage lockout
- Input over-voltage shutdown
- Thermal shutdown
- Output current limit and short circuit protection
- Active back bias limit
- Output over-voltage protection

### Screening/Qualification

- AS9100 and ISO 9001 certified facility
- Qualified to MIL-STD-810
- Available with S-Grade or M-Grade screening
- Pre-cap inspection per IPC-A-610, Class III
- Temperature cycling per MIL-STD-883, Method 1010, Condition B, 10 cycles
- Burn-In at 100 °C baseplate temperature
- Final visual inspection per MIL-STD-883, Method 2009
- Full component traceability



# SynQor®

## Technical Specification

**MCOTS-C-48-15-SG**

**Output: 15V**

**Current: 3.3A**

### BLOCK DIAGRAM

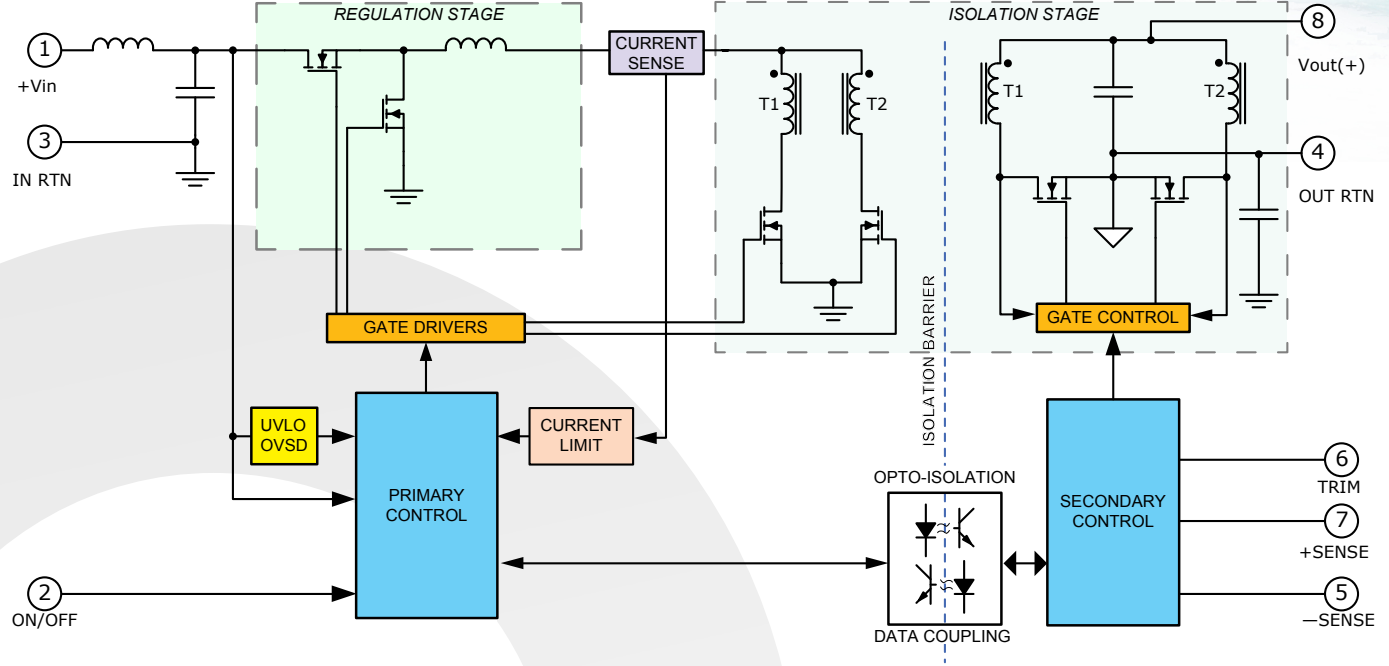

### TYPICAL CONNECTION DIAGRAM

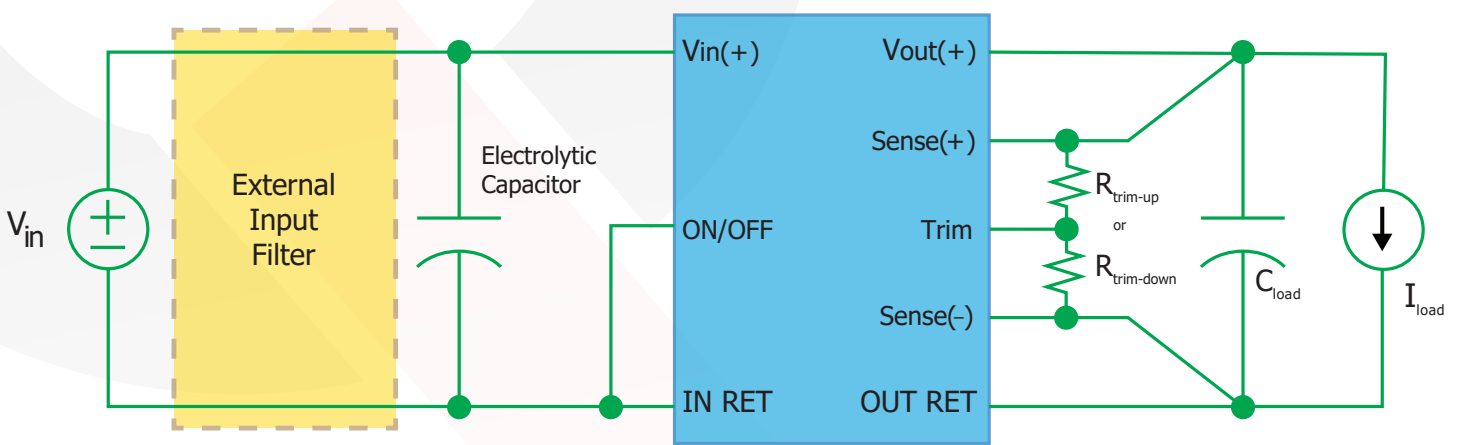

## MCOTS-C-48-15-SG ELECTRICAL CHARACTERISTICS

Tb = 25 °C, Vin = 48 Vdc unless otherwise noted; full operating temperature range is -55 °C to +100 °C baseplate temperature with appropriate power derating. Specifications subject to change without notice.

Parameter	Min.	Typ.	Max.	Units	Notes & Conditions
<b>ABSOLUTE MAXIMUM RATINGS</b>					
Input Voltage					
Non-Operating	-1		100	V	Continuous
Operating			75	V	Continuous
Operating Transient Protection			100	V	100 ms
Isolation Voltage					
Input to Output			2250	V dc	
Input to Base-Plate			2250	V dc	
Output to Base-Plate			2250	V dc	
Operating Temperature	-55		100	°C	Baseplate temperature
Storage Temperature	-65		135	°C	
Voltage at ON/OFF input pin	-2		8	V	
<b>INPUT CHARACTERISTICS</b>					
Operating Input Voltage Range	34	48	75	V	
Input Under-Voltage Lockout					
Turn-On Voltage Threshold	31.2	32.5	33.9	V	
Turn-Off Voltage Threshold	29.6	31	32.2	V	
Lockout Voltage Hysteresis		1.5		V	
Recommended External Input Capacitance		100		µF	Typical ESR 0.2-1.0 Ω; See Note 4
Input Filter Component Values (L\C)		1.0\3.9		µH\µF	Internal values; see Figure E
Maximum Input Current			2.1	A	Vin min; trim up; in current limit
No-Load Input Current		70	90	mA	
Disabled Input Current		10	14	mA	
Response to Input Transient		200		mV	250 V/ms; See Figure 12
Input Terminal Ripple Current		70		mA	RMS
Recommended Input Fuse			20	A	Fast acting external fuse recommended
<b>OUTPUT CHARACTERISTICS</b>					
Output Voltage Set Point	14.85	15.00	15.15	V	
Output Voltage Regulation					
Over Line		±0.1	±0.3	%	
Over Load		±0.1	±0.3	%	
Over Temperature	-225		225	mV	
Total Output Voltage Range	14.625		15.375	V	Over sample, line, load, temperature & life
Output Voltage Ripple and Noise					20 MHz bandwidth; See Note 1
Peak-to-Peak	0	80	160	mV	Full load
RMS		25	50	mV	Full load
Operating Output Current Range	0		3.3	A	Subject to thermal derating
Output DC Current-Limit Inception	3.5	4.2	4.9	A	Output Voltage 20% Low
Output DC Current-Limit Shutdown Voltage		12.0		V	
Back-Drive Current Limit while Enabled		0.9		A	Negative current drawn from output
Back-Drive Current Limit while Disabled		5		mA	Negative current drawn from output
Maximum Output Capacitance			1200	µF	Vout nominal at full load (resistive); See Note 2
Output Voltage during Load Current Transient					
Step Change in Output Current (0.1 A/µs)		350		mV	50% to 75% to 50% Iout max
Settling Time		200		µs	To within 1% Vout nom
Output Voltage Trim Range	-10		10	%	Across Pins 8&4; Figure C
Output Voltage Remote Sense Range			10	%	Across Pins 8&4
Output Over-Voltage Protection	17.9	18.9	20.0	V	Over full temp range
<b>EFFICIENCY</b>					
100% Load		86.5		%	See Figure 1 for efficiency curve
50% Load		87		%	See Figure 1 for efficiency curve



**MCOTS-C-48-15-SG**

**Output: 15V**

**Current: 3.3A**

# Technical Specification

## MCOTS-C-48-15-SG ELECTRICAL CHARACTERISTICS

Tb = 25 °C, Vin = 48 Vdc unless otherwise noted; full operating temperature range is -55 °C to +100 °C baseplate temperature with appropriate power derating. Specifications subject to change without notice.

Parameter	Min.	Typ.	Max.	Units	Notes & Conditions
<b>DYNAMIC CHARACTERISTICS</b>					
Turn-On Transient					
Turn-On Time		40		ms	Full load, Vout=90% nom.
Typical Start-Up Inhibit Period	100	120	150	ms	Figure F
Initial Start-Up Inhibit Period		15		ms	Figure F
Output Voltage Overshoot		0		%	Maximum Output Capacitance
<b>ISOLATION CHARACTERISTICS</b>					
Isolation Voltage (dielectric strength)					See Absolute Maximum Ratings
Isolation Resistance		30		MΩ	
Isolation Capacitance (input to output)		N/A		pF	See Note 5
<b>TEMPERATURE LIMITS FOR POWER DERATING CURVES</b>					
Semiconductor Junction Temperature			125	°C	Package rated to 150 °C
Board Temperature			125	°C	UL rated max operating temp 130 °C
Transformer Temperature			125	°C	
Maximum Baseplate Temperature, Tb			100	°C	
<b>FEATURE CHARACTERISTICS</b>					
Switching Frequency		500		kHz	Isolation stage switching freq. is half this
ON/OFF Control					
Off-State Voltage	1.5		8	V	
On-State Voltage	-2		1	V	
ON/OFF Control					
Pull-Up Voltage		5		V	Application notes Figures A & B
Pull-Up Resistance		82.5		kΩ	
Over-Temperature Shutdown OTP Trip Point		125		°C	Average PCB Temperature
Over-Temperature Shutdown Restart Hysteresis		10		°C	
<b>RELIABILITY CHARACTERISTICS</b>					
Calculated MTBF per MIL-HDBK-217F		3.8		10 <sup>6</sup> Hrs.	Ground Benign, 70°C Tb
Calculated MTBF per MIL-HDBK-217F		0.68		10 <sup>6</sup> Hrs.	Ground Mobile, 70°C Tb

Note 1: Output is terminated with 1 μF ceramic and 15 μF low-ESR tantalum capacitors.

Note 2: For applications requiring reduced output voltage ripple and noise, consult SynQor applications support (email: support@synqor.com)

Note 3: Recommended minimum output capacitance is defined in figure 17. The product will function without any external capacitance but may exceed the output ripple specifications.

Note 4: Contact SynQor Applications Support for Power derating curves with different thermal solutions (e-mail: support@synqor.com).

Note 5: An input capacitor with series resistance is necessary to provide system stability. See "Input System Instability" in the applications section

Note 6: Isolation capacitance can be added external to the module

## STANDARDS COMPLIANCE

Parameter	Notes & Conditions
<b>STANDARDS COMPLIANCE</b>	
UL 62368-1	Pending
CAN/CSA-C22.2 No. 62368-1	Basic Insulation
EN 62368	

Note: An external input fuse must always be used to meet these safety requirements. Contact SynQor for official safety certificates on new releases or download from the SynQor website.

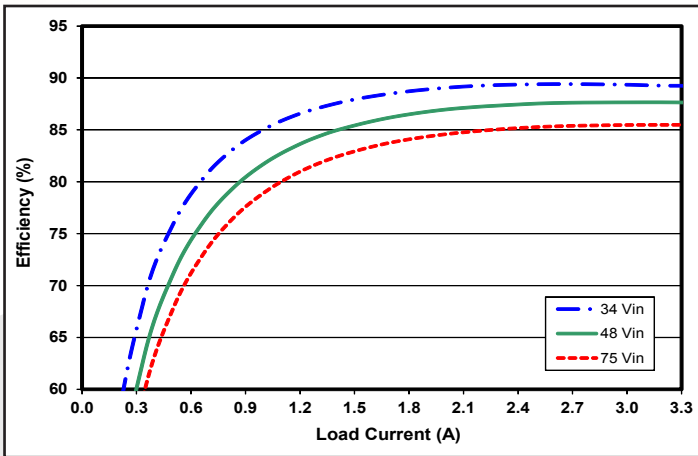

Figure 1: Efficiency at nominal output voltage vs. load current for minimum, nominal, and maximum input voltage at 25°C.

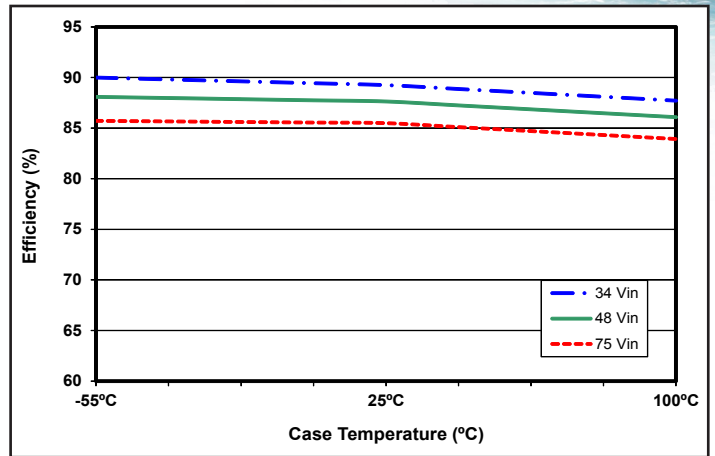

Figure 2: Efficiency at nominal output voltage and 100% rated power vs. case temperature for minimum, nominal, and maximum input voltage.

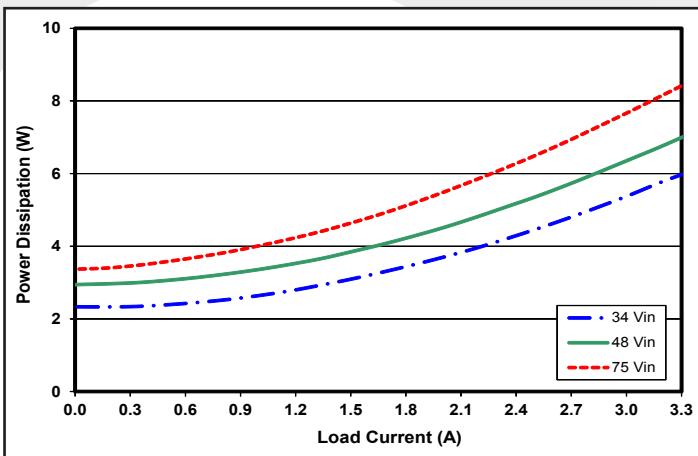

Figure 3: Power dissipation at nominal output voltage vs. load current for minimum, nominal, and maximum input voltage at  $T_{case}=25^{\circ}C$ .

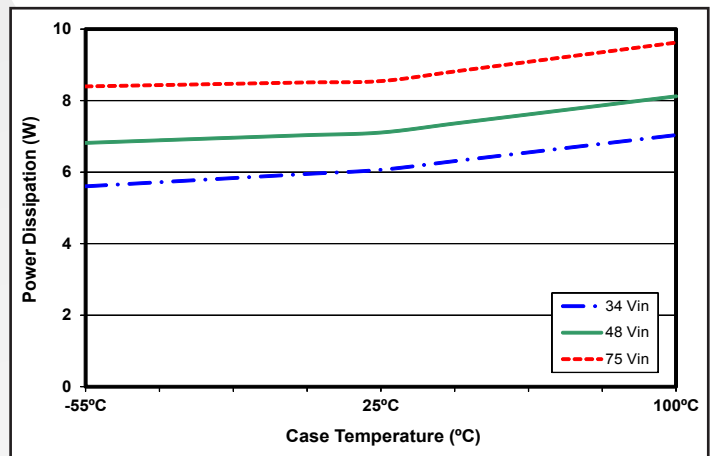

Figure 4: Power dissipation at nominal output voltage and 100% rated power vs. case temperature for minimum, nominal, and maximum input voltage.

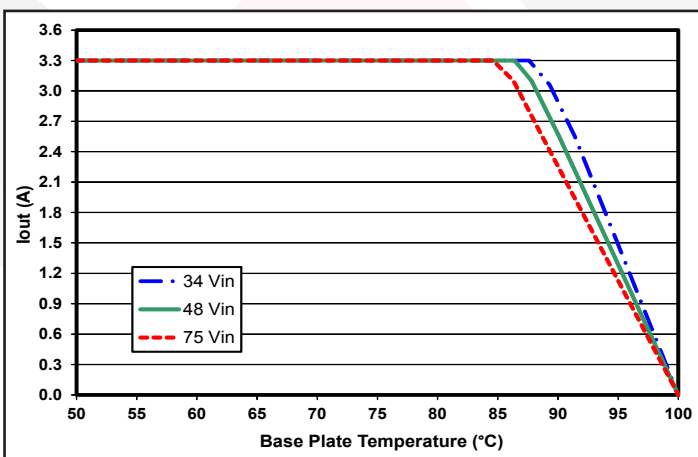

Figure 5: Maximum output current vs. baseplate temperature. Airflow rate of 300 LFM with air flowing from Vin(-) to Vin(+). See Note 3.

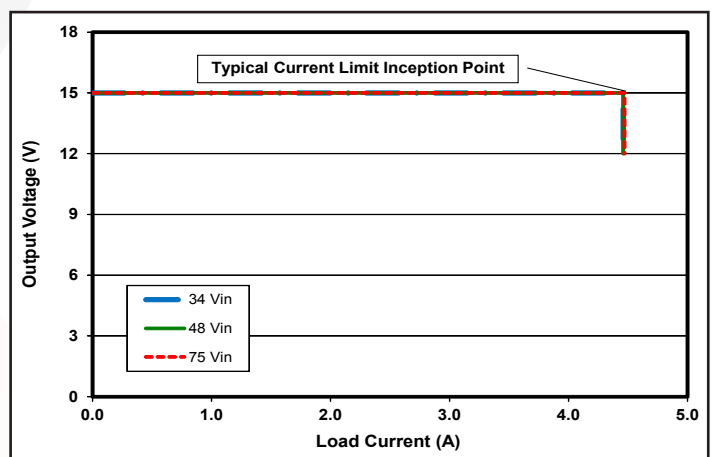

Figure 6: Output voltage vs. load current showing typical current limit inception curves. See Current Limit section in the Application Notes.



**MCOTS-C-48-15-SG**

**Output: 15V**

**Current: 3.3A**

**Technical Specification**

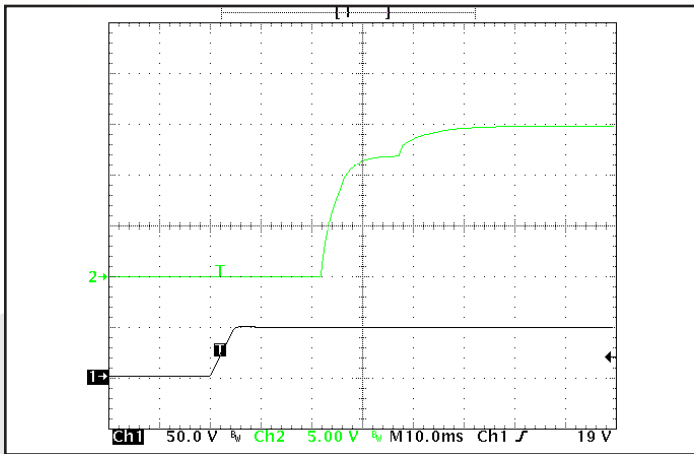

Figure 7: Turn-on transient at full load initiated by Nominal  $V_{in}$ . ON/OFF Pin previously low. Ch 1:  $V_{in}$  (50V/div). Ch 2:  $V_{out}$  (5V/div), Time (10ms/div).

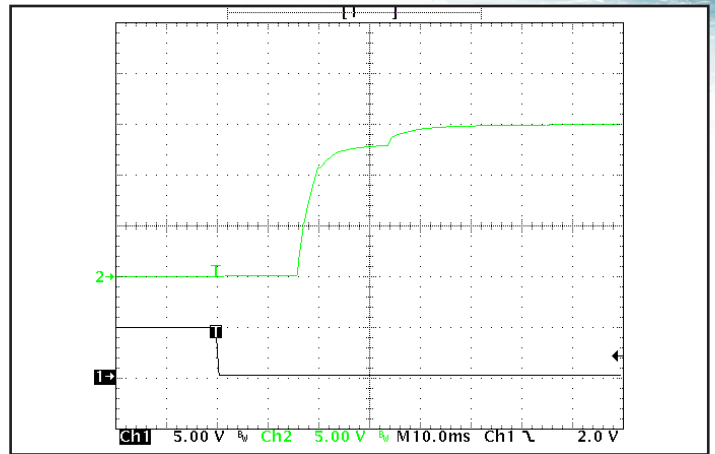

Figure 8: Typical startup waveform. Input voltage pre-applied, Ch 1: ON/OFF Pin (5V/div). Ch 2:  $V_{out}$  (5V/div), Time (10ms/div).

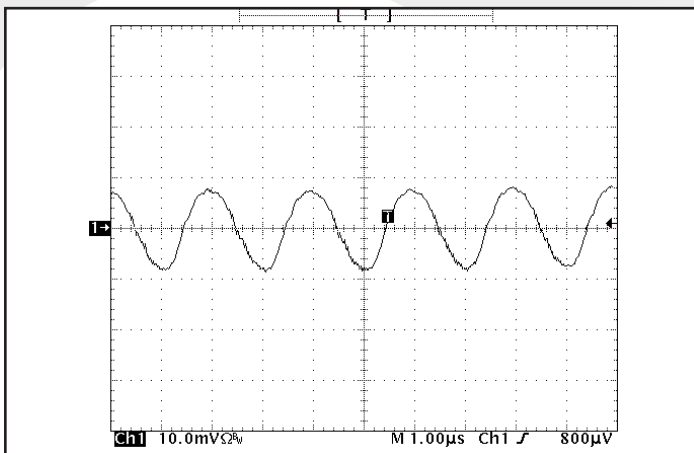

Figure 9: Input terminal current ripple,  $i_c$ , at full rated output current and nominal input voltage with SynQor MCOTS filter module (100 mA/div). Bandwidth: 20MHz. See Figure 17. Time (1µs/div).

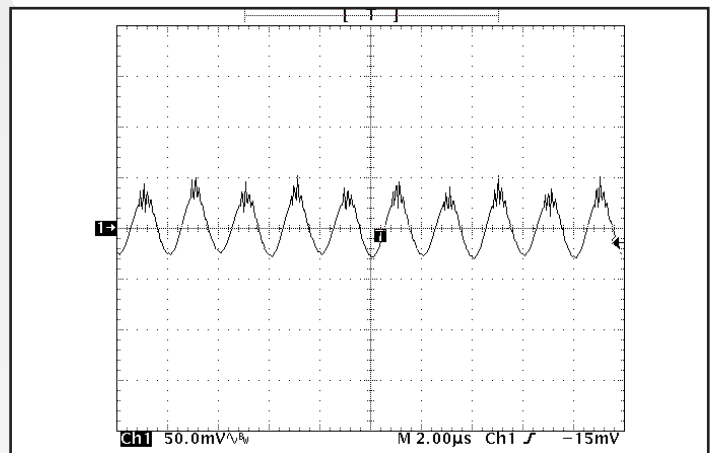

Figure 10: Output voltage ripple,  $V_{out}$ , at nominal input voltage and rated load current (50 mV/div). Load capacitors: 1µF ceramic and 15µF tantalum. Bandwidth: 20 MHz. See Figure 17. Time (2µs/div).

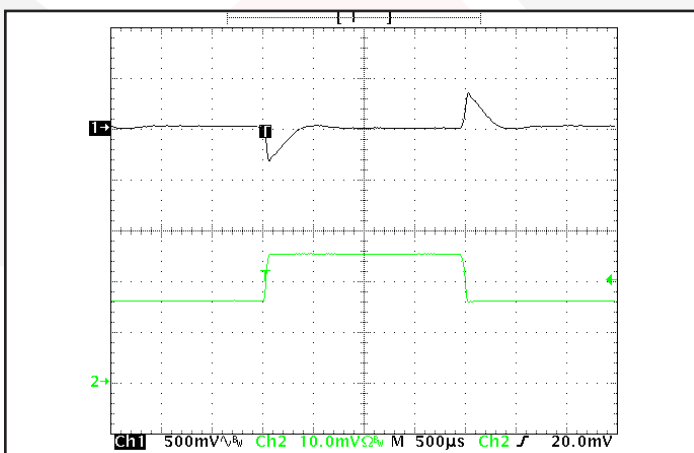

Figure 11: Output voltage response to step-change in load current (50%-75%-50% of  $I_{out(max)}$ ;  $di/dt = 0.1 A/\mu s$ ). Load capacitors: 1µF ceramic and 15µF tantalum. Ch 1:  $V_{out}$  (500mV/div), Ch 2:  $I_{out}$  (1A/div), Time (500µs/div).

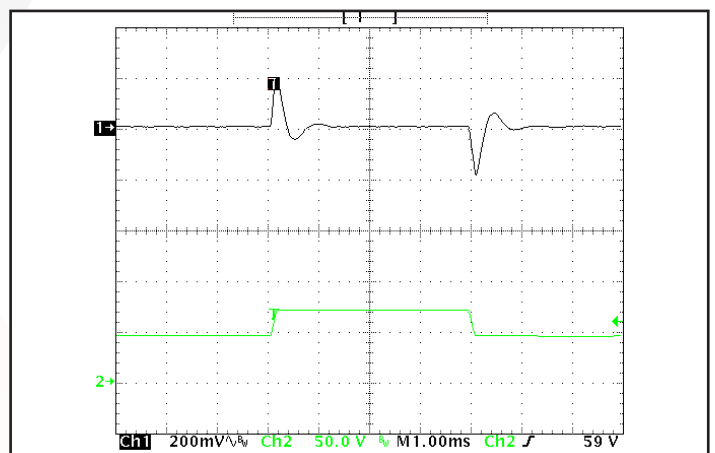

Figure 12: Output voltage response to step-change in input voltage (250V/ms). Load capacitors: 1µF ceramic and 15µF tantalum. Ch 1:  $V_{out}$  (200mV/div), Ch 2:  $V_{in}$  (50V/div), Time (1ms/div).

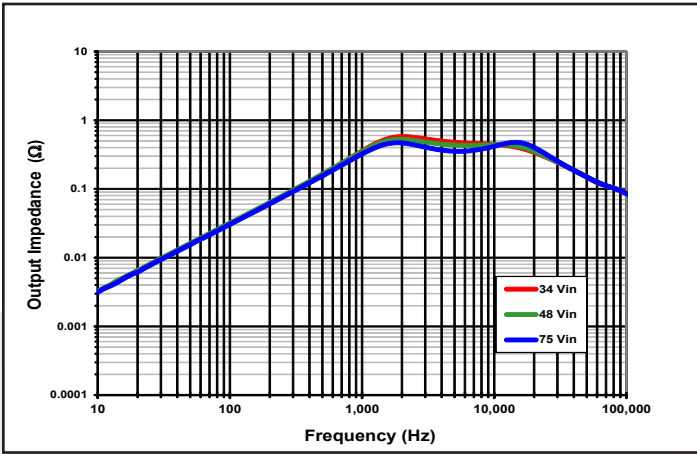

Figure 13: Magnitude of incremental output impedance ( $Z_{out} = v_{out}/i_{out}$ ) for minimum, nominal, and maximum input voltage at full rated power.

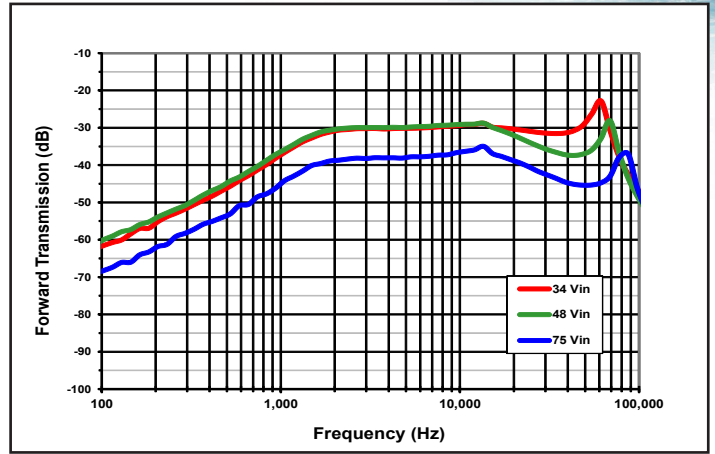

Figure 14: Magnitude of incremental forward transmission ( $FT = v_{out}/v_{in}$ ) for minimum, nominal, and maximum input voltage at full rated power.

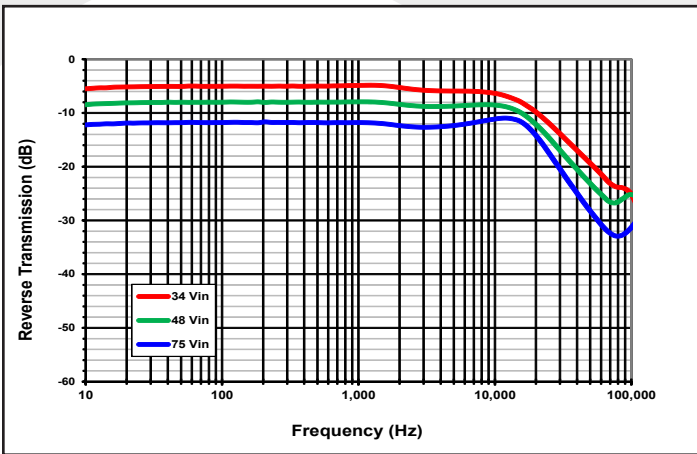

Figure 15: Magnitude of incremental reverse transmission ( $RT = i_{in}/i_{out}$ ) for minimum, nominal, and maximum input voltage at full rated power.

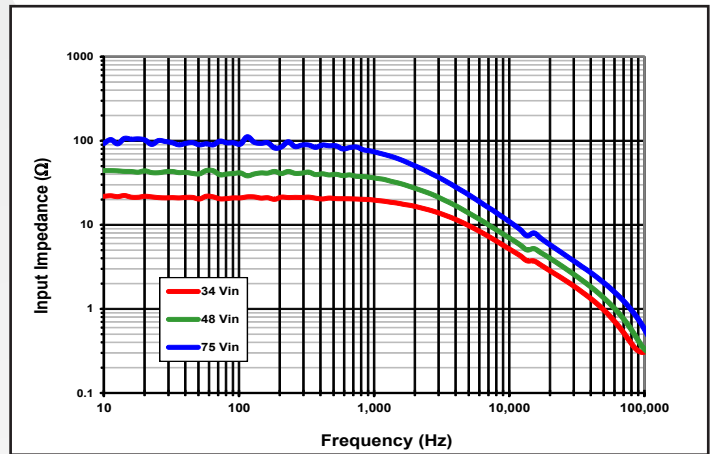

Figure 16: Magnitude of incremental input impedance ( $Z_{in} = v_{in}/i_{in}$ ) for minimum, nominal, and maximum input voltage at full rated power.

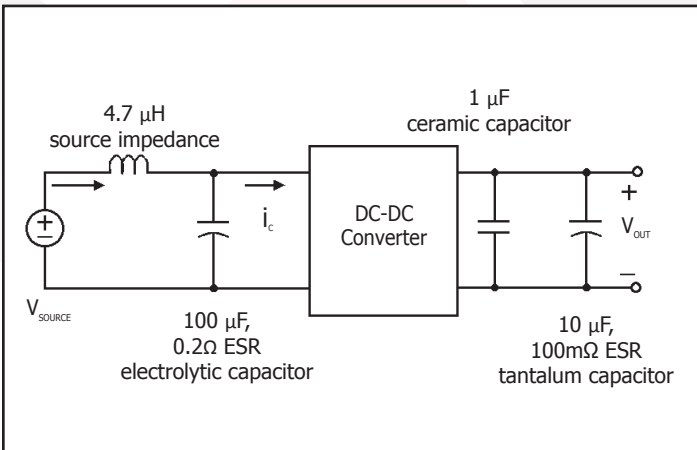

Figure 17: Test set-up diagram showing measurement points for Input Terminal Ripple Current (Figure 9) and Output Voltage Ripple (Figure 10).

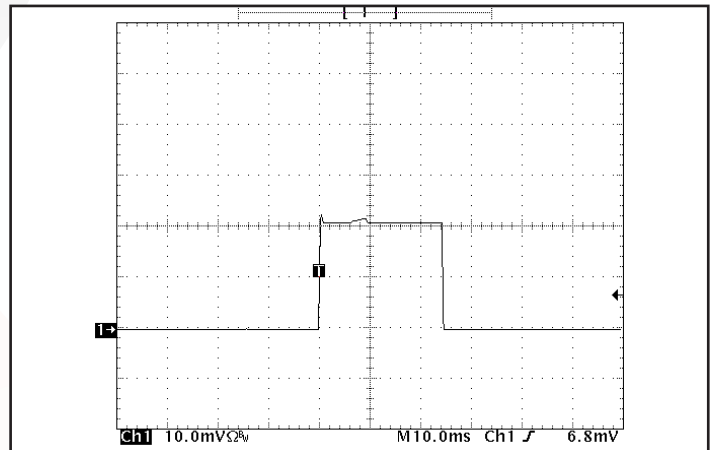

Figure 18: Load current (5A/div) as a function of time (10ms/div and 100ms/div) when the converter attempts to turn on into a 1 mΩ short circuit.



**MCOTS-C-48-15-SG**

**Output: 15V**

**Current: 3.3A**

# Technical Specification

## BASIC OPERATION AND FEATURES

This converter switches at a fixed frequency for predictable EMI performance. Rectification of the transformer's output is accomplished with synchronous rectifiers. These devices, which are MOSFETs with a very low on-state resistance, dissipate far less energy than Schottky diodes. This is the primary reason that the converter has such high efficiency, even at very low output voltages and very high output currents.

These converters are offered totally encased to withstand harsh environments and thermally demanding applications. Dissipation throughout the converter is so low that it does not require a heatsink for operation in many applications; however, adding a heatsink provides improved thermal derating performance in extreme situations.

This series of converters use the industry standard footprint and pin-out configuration.

## CONTROL FEATURES

**REMOTE ON/OFF (Pin 2):** The ON/OFF input, Pin 2, permits the user to control when the converter is on or off. This input is referenced to the return terminal of the input bus, Vin(-). The ON/OFF signal is active low (meaning that a low turns the converter on). Figure A details four possible circuits for driving the ON/OFF pin. Figure B is a detailed look of the internal ON/OFF circuitry.

**REMOTE SENSE(±) (Pins 7 and 5):** The SENSE(±) inputs correct for voltage drops along the conductors that connect the converter's output pins to the load.

Pin 7 should be connected to Vout(+) and Pin 5 should be connected to Vout(-) at the point on the board where regulation is desired. A remote connection at the load can adjust for a voltage drop only as large as that specified in this datasheet, that is

$$[V_{out(+)} - V_{out(-)}] - [V_{sense(+)} - V_{sense(-)}] \leq \text{Sense Range } \% \times V_{out}$$

Pins 7 and 5 must be connected for proper regulation of the output voltage. If these connections are not made, the converter will deliver an output voltage that is slightly higher than its specified value.

**Note:** the output over-voltage protection circuit senses the voltage across the output (pins 8 and 4) to determine when it should trigger, not the voltage across the converter's sense leads (pins 7 and 5). Therefore, the resistive drop on the board should be small enough so that output OVP does not trigger, even during load transients.

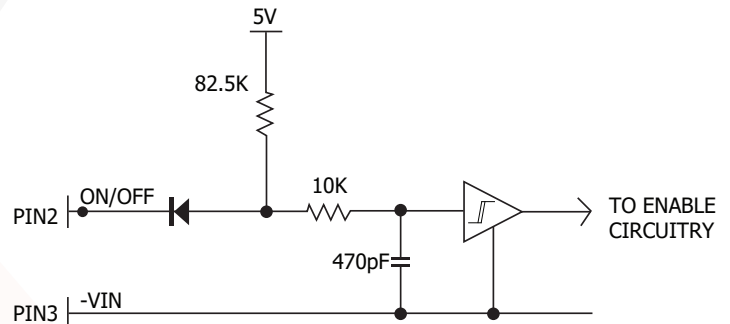
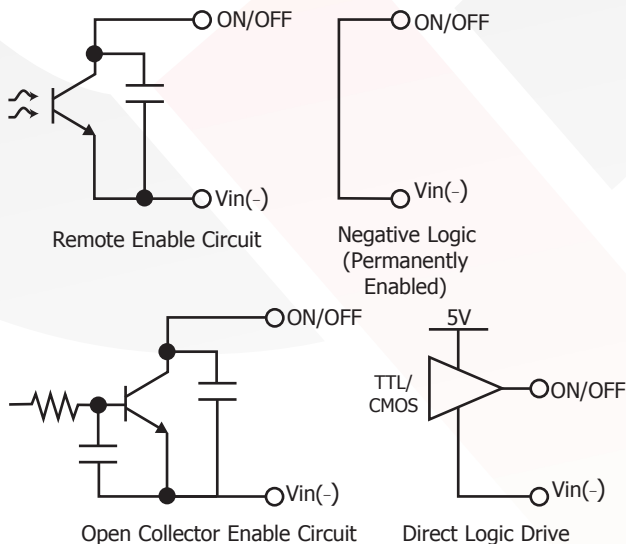

Figure A: Various circuits for driving the ON/OFF pin.

Figure B: Internal ON/OFF pin circuitry





**MCOTS-C-48-15-SG**

**Output: 15V**

**Current: 3.3A**

# Technical Specification

**OUTPUT VOLTAGE TRIM (Pin 6):** The TRIM input permits the user to adjust the output voltage across the sense leads up or down according to the trim range specifications.

To decrease the output voltage, the user should connect a resistor between Pin 6 and Pin 5 (SENSE(-) input). For a desired decrease of the nominal output voltage, the value of the resistor should be

$$R_{\text{trim-down}} = \left( \frac{511}{\Delta\%} \right) - 10.22 \text{ (k}\Omega\text{)}$$

where

$$\Delta\% = \left| \frac{V_{\text{nominal}} - V_{\text{desired}}}{V_{\text{nominal}}} \right| \times 100\%$$

To increase the output voltage, the user should connect a resistor between Pin 6 and Pin 7 (SENSE(+) input). For a desired increase of the nominal output voltage, the value of the resistor should be

$$R_{\text{trim-up}} = \left( \frac{5.11V_{\text{out}} \times (100 + \Delta\%)}{1.225 \Delta\%} - \frac{511}{\Delta\%} - 10.22 \right) \text{ (k}\Omega\text{)}$$

where  $V_{\text{out}}$  = Nominal Output Voltage

Trim graphs show the relationship between the trim resistor value and Rtrim-up and Rtrim-down, showing the total range the output voltage can be trimmed up or down.

Note: the TRIM feature does not affect the voltage at which the output over-voltage protection circuit is triggered. Trimming the output voltage too high may cause the over-voltage protection circuit to engage, particularly during transients.

It is not necessary for the user to add capacitance at the Trim pin. The node is internally bypassed to eliminate noise.

**Total DC Variation of  $V_{\text{out}}$ :** For the converter to meet its full specifications, the maximum variation of the dc value of  $V_{\text{out}}$ , due to both trimming and remote load voltage drops, should not be greater than that specified for the output voltage trim range.

## PROTECTION FEATURES

**Input Under-Voltage Lockout:** The converter is designed to turn off when the input voltage is too low, helping avoid an input system instability problem, described in more detail in the application note titled "Input System Instability" on our website. The lockout circuitry is a comparator with dc hysteresis. When the input voltage is rising, it must exceed the typical Turn-On Voltage Threshold value (listed on the specifications page) before the converter will turn on. Once the converter is on, the input voltage must fall below the typical Turn-Off Voltage Threshold value before the converter will turn off.

**Input Over-Voltage Shutdown:** The converter also has an over-voltage feature that ensures the converter will be off if the input voltage is too high. It also has a hysteresis to ensure proper operation.

**Output Over-Voltage Limit:** If the voltage across the output pins exceeds the Output Over-Voltage Protection threshold, the converter will immediately stop switching. This prevents damage to the load circuit due to 1) excessive series resistance in output current path from converter output pins to sense point, 2) a release of a short-circuit condition, or 3) a release of a current limit condition. Load capacitance determines exactly how high the output voltage will rise in response to these conditions. After 120 ms the converter will automatically restart.

**Over-Temperature Shutdown:** A temperature sensor on the converter senses the average temperature of the module. The thermal shutdown circuit is designed to turn the converter off when the temperature at the sensed location reaches the Over-Temperature Shutdown value. It will allow the converter to turn on again when the temperature of the sensed location falls by the amount of the Over-Temperature Shutdown Restart Hysteresis value.

**Output Current Limit:** If the output current exceeds the Output Current Limit threshold, the converter turns off. The converter then enters a "hiccup" mode where it repeatedly turns on and off with a 120ms (typical) off time at small duty cycle until the short circuit condition is removed. This prevents excessive heating of the converter or the load board.

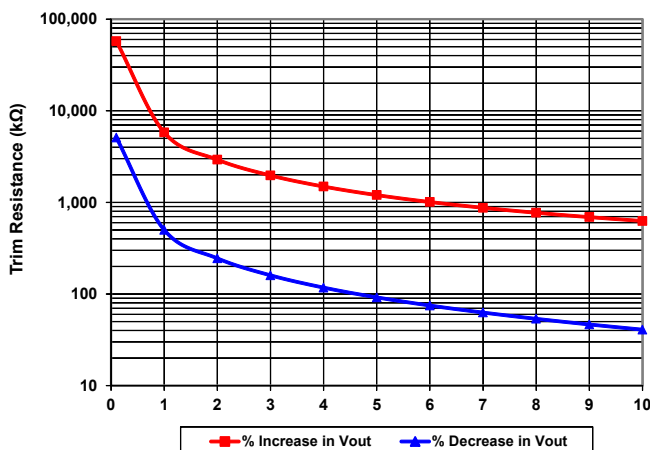
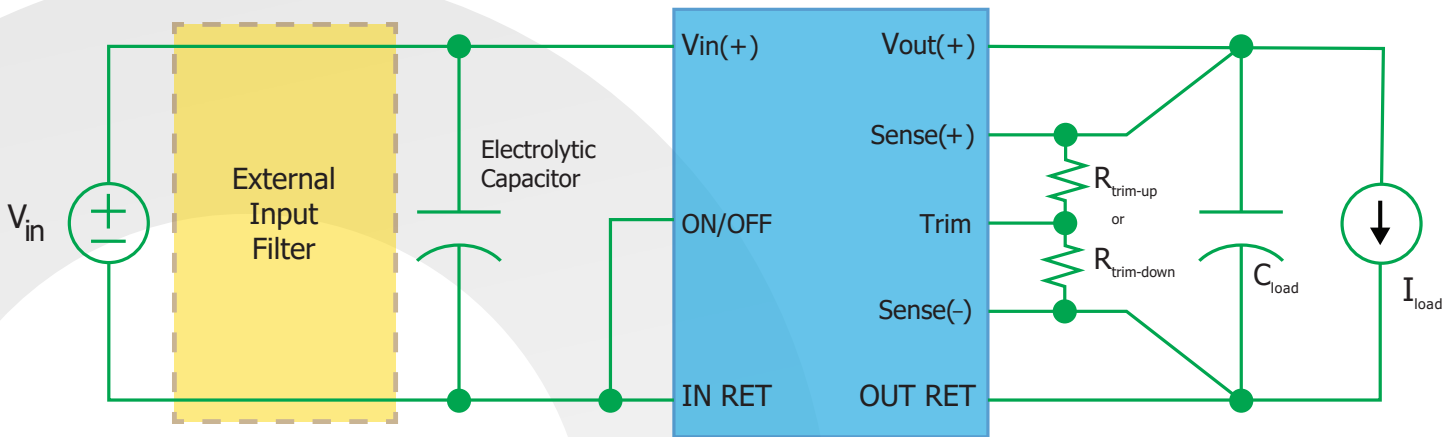

Figure C: Trim graph for trim-up, trim down.

## APPLICATION CONSIDERATIONS

**Input System Instability:** This condition can occur because any dc-dc converter appears incrementally as a negative resistance load. A detailed application note titled "Input System Instability" is available on the SynQor website which provides an understanding of why this instability arises, and shows the preferred solution for correcting it.

**Application Circuits:** Figure D provides a typical circuit diagram which details the input filtering and voltage trimming.



*Figure D: Typical application circuit (negative logic unit, permanently enabled).*

**Input Filtering and External Capacitance:** Figure E provides a diagram showing the internal input filter components. This filter dramatically reduces input terminal ripple current, which otherwise could exceed the rating of the converter's external electrolytic input capacitor. The recommended external input capacitance is specified

in the Input Characteristics section on the Electrical Characteristics page. More detailed information is available in the application note titled "EMI Characteristics" on the SynQor website.

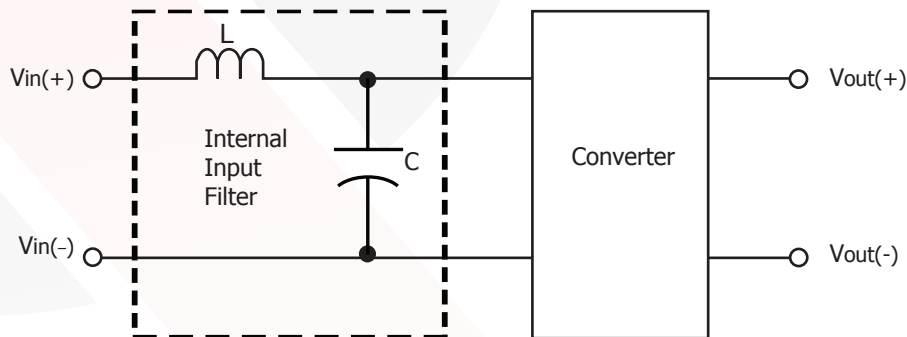

*Figure E: Internal Input Filter Diagram*



# Technical Specification

**Startup Inhibit Period:** The Startup Inhibit Period ensures that the converter will remain off for approximately 120 ms when it is shut down for any reason. When an output short is present, this generates a “hiccup” mode, which prevents the converter from overheating. In all, there are six ways that the converter can be shut down, initiating a Startup Inhibit Period:

- Input Under-Voltage Lockout
- Output Over-Voltage Protection
- Over Temperature Shutdown
- Current Limit
- Short Circuit Protection
- Turned off by the ON/OFF input

Figure F shows three turn-on scenarios, where a Startup Inhibit Period is initiated at  $t_0$ ,  $t_1$ , and  $t_2$ :

Before time  $t_0$ , when the input voltage is below the UVL threshold, the unit is disabled by the Input Under-Voltage Lockout feature. When the input voltage rises above the UVL threshold, the Input Under-Voltage lockout is released, and a Power-up Inhibit Time is initiated. At the end of this delay, the ON/OFF pin is evaluated, and since it is active, the unit turns on.

At time  $t_1$ , the unit is disabled by the ON/OFF pin, and it cannot be enabled again until the Startup Inhibit Period has elapsed.

When the ON/OFF pin goes high after  $t_2$ , the Startup Inhibit Period has elapsed, and the output turns on within the typical Turn-On Time.

**Thermal Considerations:** The maximum operating base-plate temperature,  $T_B$ , is 100 °C. Refer to the thermal derating curve, Figure 5, to see the available output current at baseplate temperatures below 100 °C.

A power derating curve can be calculated for any heatsink that is attached to the base-plate of the converter. It is only necessary to determine the thermal resistance,  $R_{TH_{BA}}$ , of the chosen heatsink between the base-plate and the ambient air for a given airflow rate. This information is usually available from the heatsink vendor. The following formula can then be used to determine the maximum power the converter can dissipate for a given thermal condition:

$$P_{diss}^{max} = \frac{T_B - T_A}{R_{TH_{BA}}}$$

This value of power dissipation can then be used in conjunction with the data shown in Figure 3 to determine the maximum load current (and power) that the converter can deliver in the given thermal condition.

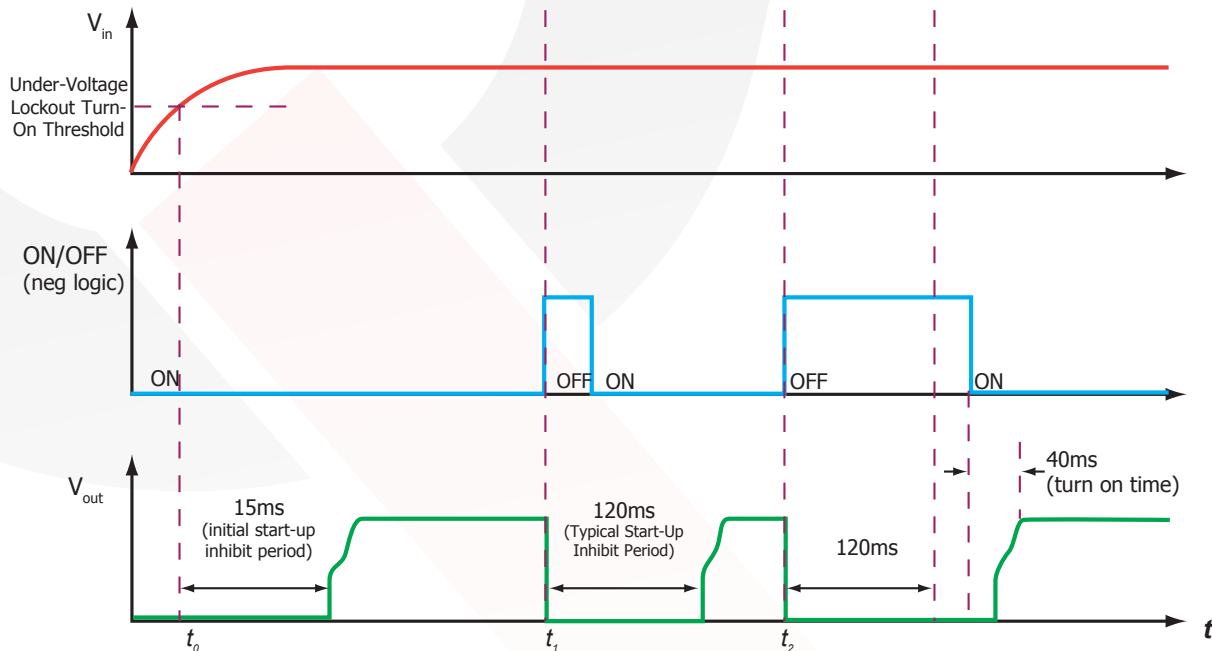
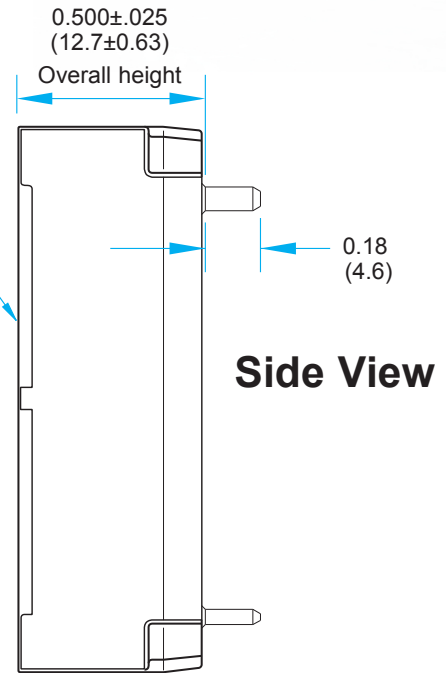
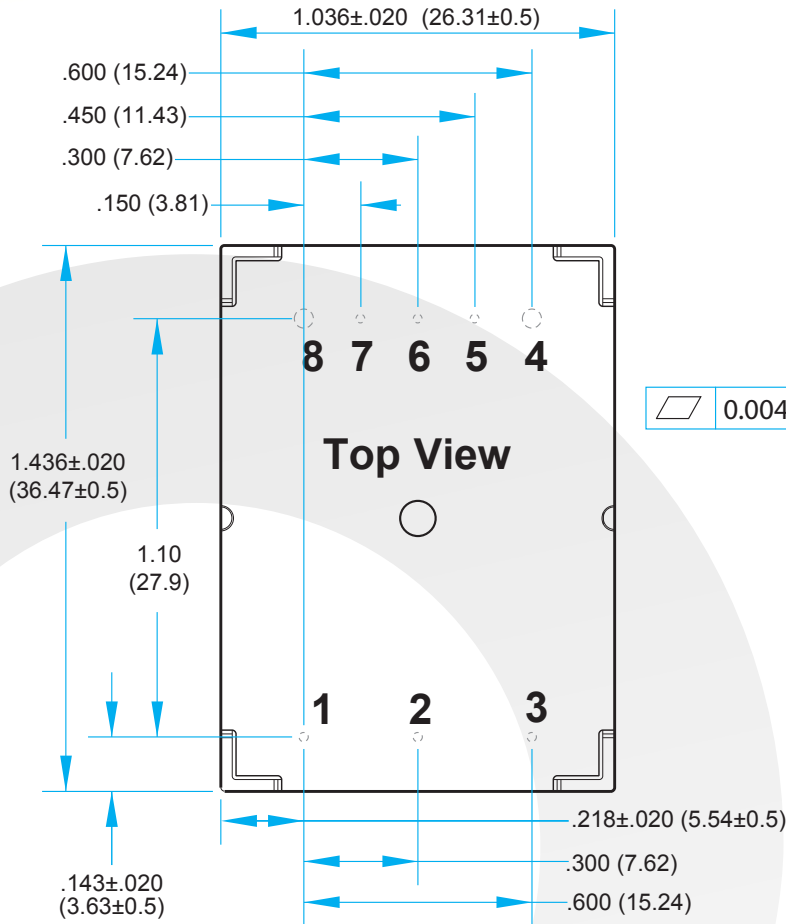

Figure F: Start-up Inhibit Period (turn-on time not to scale)



### NOTES

- 1)Baseplate flatness tolerance is 0.004" (.10mm) TIR for surface.
- 2)Pins 1-3, 5-7 are 0.040" (1.02mm) diameter, with 0.080" (2.03mm) diameter standoff shoulders.
- 3)Pins 4 and 8 are 0.062" (1.57 mm) diameter with 0.100" (2.54 mm) diameter standoff shoulders.
- 4)All Pins: Material – Copper Alloy; Finish – Matte Tin over Nickel plate
- 5)Undimensioned components are shown for visual reference only.
- 6)Weight: 1.10 oz (31.2 g) Typical
- 7)All dimensions in inches (mm)  
Tolerances: x.xx +/-0.02 in. (x.x +/-0.5mm)  
x.xxx +/-0.010 in. (x.xx +/-0.25mm)
- 8)Workmanship: Meets or exceeds IPC-A-610 Class II
- 9)Recommended pin length is 0.03" (0.76mm) greater than the PCB thickness.

### PIN DESIGNATIONS

Pin	Label	Name	Function
1	+VIN	Vin(+)	Positive input voltage
2	ON/OFF	ON/OFF	TTL input to turn converter on and off, referenced to Vin(-), with internal pull up.
3	IN RTN	Vin(-)	Negative input voltage
4	OUT RTN	Vout(-)	Negative output voltage
5	-SNS	SENSE(-)	Negative remote sense(see note 1)
6	TRIM	TRIM	Output voltage trim (see note 2)
7	+SNS	SENSE(+)	Positive remote sense (see note 3)
8	+VOUT	Vout(+)	Positive output voltage

### Notes:

- 1) SENSE(-) should be connected to Vout(-) either remotely or at the converter.
- 2) Leave TRIM pin open for nominal output voltage.
- 3) SENSE(+) should be connected to Vout(+) either remotely or at the converter.

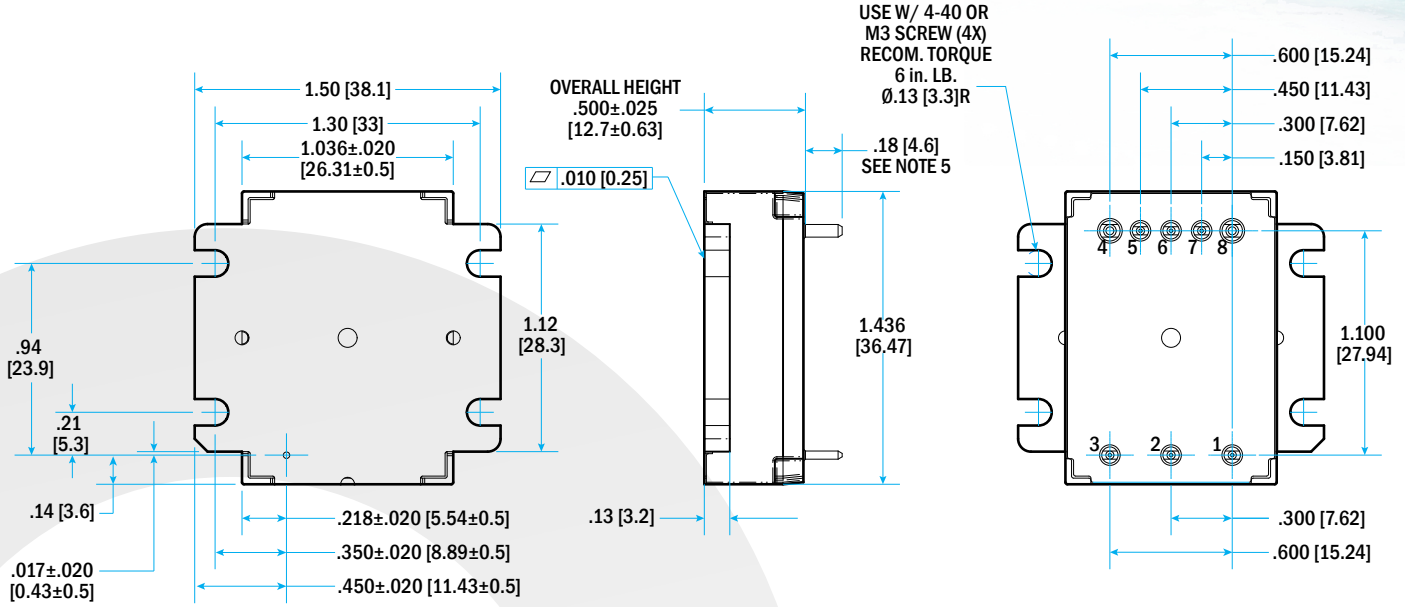

### NOTES

- 1) Applied torque per screw should not exceed 6in-lb
- 2) Baseplate flatness tolerance is 0.01" (.25mm) TIR for surface.
- 3) Pins 1-3, 5-7 are 0.040" (1.02mm) diameter, with 0.080" (2.03mm) diameter standoff shoulders.
- 4) Pins 4 and 8 are 0.062" (1.57 mm) diameter with 0.100" (2.54 mm) diameter standoff shoulders.
- 5) All Pins: Material – Copper Alloy  
Finish - Matte Tin over Nickel plate
- 6) Weight: 1.30 oz (36.9 g) Typical
- 7) Undimensioned components are shown for visual reference only.
- 8) All dimensions in inches (mm)  
Tolerances: x.xx +/-0.02 in. (x.x +/-0.5mm)  
x.xxx +/-0.010 in. (x.xx +/-0.25mm)
- 9) Workmanship: Meets or exceeds IPC-A610 Class II

### PIN DESIGNATIONS

Pin	Label	Name	Function
1	+VIN	Vin(+)	Positive input voltage
2	ON/OFF	ON/OFF	TTL input to turn converter on and off, referenced to Vin(-), with internal pull up.
3	IN RTN	Vin(-)	Negative input voltage
4	OUT RTN	Vout(-)	Negative output voltage
5	-SNS	SENSE(-)	Negative remote sense(see note 1)
6	TRIM	TRIM	Output voltage trim (see note 2)
7	+SNS	SENSE(+)	Positive remote sense (see note 3)
8	+VOUT	Vout(+)	Positive output voltage

#### Notes:

- 1) SENSE(-) should be connected to Vout(-) either remotely or at the converter.
- 2) Leave TRIM pin open for nominal output voltage.
- 3) SENSE(+) should be connected to Vout(+) either remotely or at the converter.

### Mil-COTS Qualification

Test Name	Details	# Tested (# Failed)	Consistent with MIL-STD-883F Method
Life Testing	Visual, mechanical and electrical testing before, during and after 1000 hour burn-in @ full load	15 (0)	Method 1005.8
Shock-Vibration	Visual, mechanical and electrical testing before, during and after shock and vibration tests	5 (0)	MIL-STD-202, Methods 201A & 213B
Humidity	+85 °C, 95% RH, 1000 hours, 2 minutes on / 6 hours off	8 (0)	Method 1004.7
Temperature Cycling	500 cycles of -55 °C to +100 °C (30 minute dwell at each temperature)	10 (0)	Method 1010.8, Condition A
Solderability	15 pins	15 (0)	Method 2003
DMT	-65 °C to +110 °C across full line and load specifications in 5 °C steps	7 (0)	
Altitude	70,000 feet (21 km), see Note	2 (0)	

Note: A conductive cooling design is generally needed for high altitude applications because of naturally poor convective cooling at rare atmospheres.

### Mil-COTS Converter and Filter Screening

Screening	Process Description	S-Grade	M-Grade
Baseplate Operating Temperature		-55 °C to +100 °C	-55 °C to +100 °C
Storage Temperature		-65 °C to +135 °C	-65 °C to +135 °C
Pre-Cap Inspection	IPC-A-610, Class III	•	•
Temperature Cycling	MIL-STD-883F, Method 1010, Condition B, 10 Cycles		•
Burn-In	100 °C Baseplate	12 Hours	96 Hours
Final Electrical Test	100%	25 °C	-55 °C, +25 °C, +100 °C
Final Visual Inspection	MIL-STD-883F, Method 2009	•	•

### Mil-COTS MIL-STD-810G Qualification Testing

MIL-STD-810G Test	Method	Description
Fungus	508.6	Table 508.6-I
Altitude	500.5 - Procedure I	Storage: 70,000 ft / 2 hr duration
	500.5 - Procedure II	Operating: 70,000 ft / 2 hr duration; Ambient Temperature
Rapid Decompression	500.5 - Procedure III	Storage: 8,000 ft to 40,000 ft
Acceleration	513.6 - Procedure II	Operating: 15 g
Salt Fog	509.5	Storage
High Temperature	501.5 - Procedure I	Storage: 135 °C / 3 hrs
	501.5 - Procedure II	Operating: 100 °C / 3 hrs
Low Temperature	502.5 - Procedure I	Storage: -65 °C / 4 hrs
	502.5 - Procedure II	Operating: -55 °C / 3 hrs
Temperature Shock	503.5 - Procedure I - C	Storage: -65 °C to 135 °C; 12 cycles
Rain	506.5 - Procedure I	Wind Blown Rain
Immersion	512.5 - Procedure I	Non-Operating
Humidity	507.5 - Procedure II	Aggravated cycle @ 95% RH (Figure 507.5-7 aggravated temp - humidity cycle, 15 cycles)
Random Vibration	514.6 - Procedure I	10 - 2000 Hz, PSD level of 1.5 g <sup>2</sup> /Hz (54.6 g <sub>rms</sub> ), duration = 1 hr/axis
Shock	516.6 - Procedure I	20 g peak, 11 ms, Functional Shock (Operating no load) (saw tooth)
	516.6 - Procedure VI	Bench Handling Shock
Sinusoidal vibration	514.6 - Category 14	Rotary wing aircraft - helicopter, 4 hrs/axis, 20 g (sine sweep from 10 - 500 Hz)
Sand and Dust	510.5 - Procedure I	Blowing Dust
	510.5 - Procedure II	Blowing Sand



**MCOTS-C-48-15-SG**

**Output: 15V**

**Current: 3.3A**

**Technical Specification**

**Ordering Information/ Part Numbering**

Example MCOTS-C-48-15-SG-N-S

Not all combinations make valid part numbers, please contact SynQor for availability.

Family	Product	Input Voltage	Output Voltage	Package	Thermal Design	Screening Level	Options
MCOTS	C: Converter	28: 16-40V 48: 34-75V	1R8: 1.8V 3R3: 3.3V 05: 5V 07: 7V 12: 12V 15: 15V 28: 28V	SG: Sixteenth Brick Giga	N: Normal F: Flanged	S: S-Grade M: M-Grade	[ ]: Standard Feature

**APPLICATION NOTES**

A variety of application notes and technical white papers can be downloaded in pdf format from our [website](#).

**Contact SynQor for further information and to order:**

Phone: 978-849-0600 Toll Free: 888-567-9596 Fax: 978-849-0602

E-mail: [power@synqor.com](mailto:power@synqor.com) Web: [www.synqor.com](http://www.synqor.com)

Address: 155 Swanson Road, Boxborough, MA 01719 USA

**WARRANTY**

SynQor offers a two (2) year limited warranty. Complete warranty information is listed on our website or is available upon request from SynQor.

**PATENTS**

SynQor holds numerous U.S. patents, one or more of which apply to most of its power conversion products. Any that apply to the product(s) listed in this document are identified by markings on the product(s) or on internal components of the product(s) in accordance with U.S. patent laws. SynQor's patents include the following:

7,050,309    7,765,687    7,787,261  
8,149,597    8,644,027