

MILITARY COTS EMI FILTER

-40V to +40V Continuous Input	40A Output Current	32.5mΩ @ 100°C Max. DC Resistance	>80dB @ 250kHz Differential Attenuation
-----------------------------------------	------------------------------	---------------------------------------------	------------------------------------------------------

FULL POWER OPERATION: -55°C to +100°C

The Mil-COTS series of EMI filters brings SynQor's field proven technology and manufacturing expertise to the military and aerospace industry. SynQor's innovative packaging approach ensures survivability in the most hostile environments. Compatible with the industry standard format, these filters have high differential-mode and common-mode attenuation, low DC resistance, and a stabilizing bulk capacitor resistor. They follow conservative component derating guidelines and they are designed and manufactured to comply with a wide range of military standards. This filter, when combined with Mil-COTS DC-DC converters, is designed to comply with MIL-STD-704, MIL-STD-1275, RTCA/DO-160, DEF-STAN 61-5 and MIL-STD-461 for a 28Vin system.

MilCOTS™

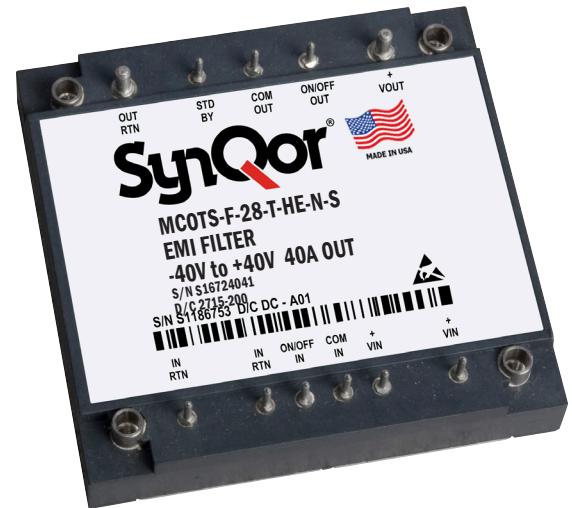

Operational Features

- Transient suppression circuitry to block voltage surges and spikes
- Soft-Start circuitry to limit in-rush charging currents
- Reverse polarity protection with a low-loss synchronous rectifier
- Output power limit for short-circuit protection
- ON/OFF pass-through circuitry
- Standby circuitry to minimize quiescent power draw
- 40 amps output current
- Very low DC resistance
- > 80 dB differential-mode attenuation at 250kHz
- > 36 dB common-mode attenuation at 250kHz
- Stabilizing bulk capacitor and damping resistor included
- All capacitors are temperature stable multi-layer ceramic
- Designed to meet most MIL-STD 461 EMI requirements

In-Line Manufacturing Process

- AS9100 and ISO 9001 Certified Facility
- Full component traceability

Mechanical Features

- Size: 2.49" x 2.39" x 0.51" (63.1 x 60.6 x 13.0 mm)
- Total weight: 4.9 oz. (140 g)
- Flanged baseplate version available

Designed and Manufactured in the USA

Safety Features - Pending

- 2250V input/output to common mode isolation
- Certified 62368-1

Specification Compliance

- MCOTS filters (with MCOTS converters) are designed to meet:
- MIL-HDBK-704-8 (A through F)
 - RTCA/DO-160 Section 16, 17, 18
 - MIL-STD-1275 (B, D) (Full power operation down to 16V_{IN})
 - DEF-STAN 61-5 (part 6)/(5, 6)
 - MIL-STD-461 (C, D, E, F)

Screening/Qualification

- Qualified to MIL-STD-810
- Available with S-Grade or M-Grade screening
- Pre-cap inspection per IPC-A-610, Class III
- Temperature cycling per MIL-STD-883, Method 1010, Condition B, 10 cycles
- Burn-In at 100 °C baseplate temperature
- Final visual inspection per MIL-STD-883, Method 2009



Technical Specification

MCOTS-F-28-T-HE
Current: 40A

Fundamental Circuit Diagram

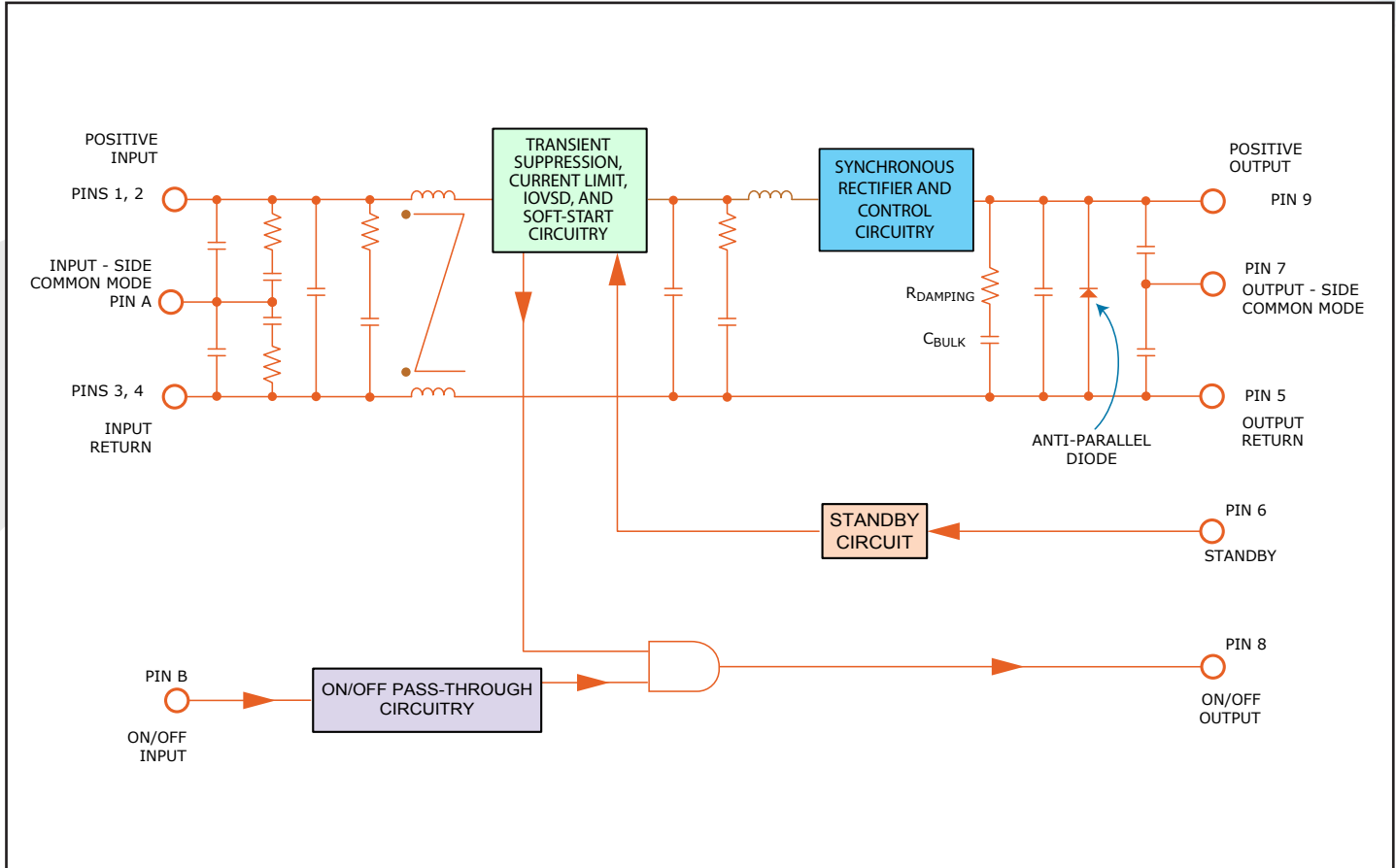

Typical Connection Diagram

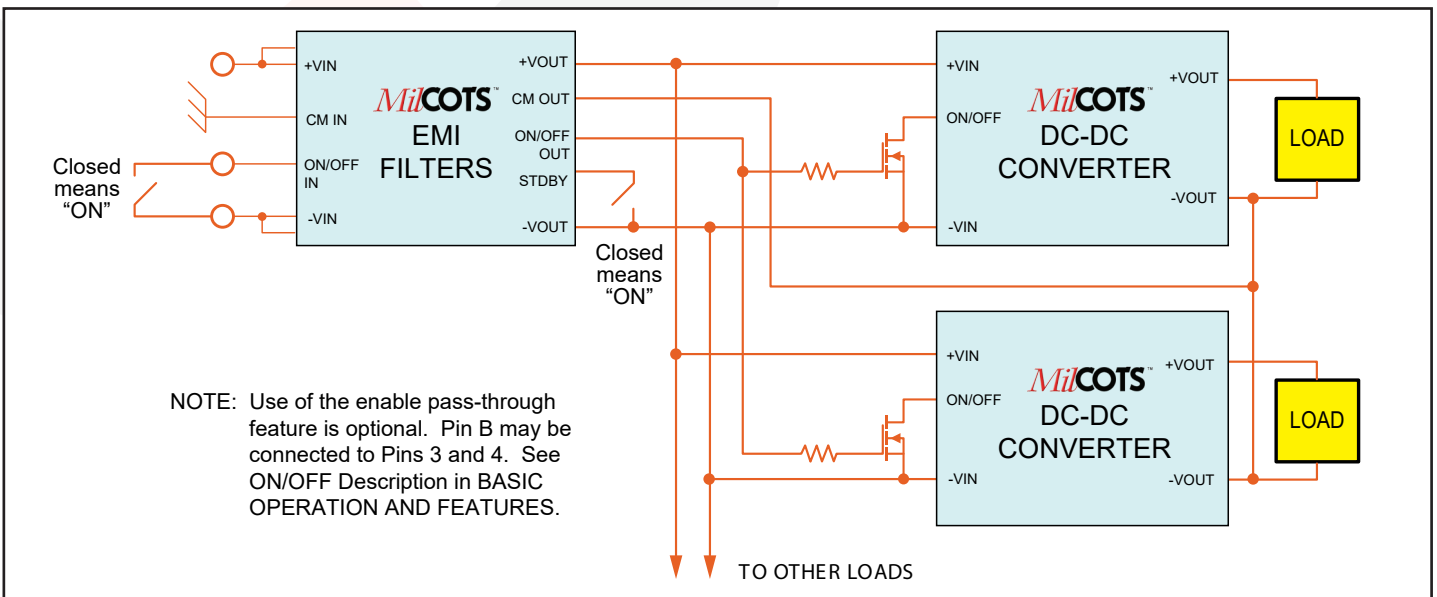



Technical Specification

MCOTS-F-28-T-HE

Current: 40A

MCOTS-F-28-T-HE ELECTRICAL CHARACTERISTICS

Parameter	Min.	Typ.	Max.	Units	Notes & Conditions
Specifications subject to change without notice					
Vin=28V DC ±5%, 25°C, Pout=600W unless otherwise specified					
ABSOLUTE MAXIMUM RATINGS					
Input Voltage					
Continuous	-40		100	V	
Transient (≤ 1 s)	-50		210	V	
Isolation Voltage	-2250		2250	V	Input/Output to Common-mode pins
Output Current			45	A	
Operating Case Temperature	-55		100	°C	Baseplate Temperature
Storage Case Temperature	-65		135	°C	
Voltage at ON/OFF IN, ON/OFF OUT	-0.5		50	V	
Voltage at STDBY	0		5	V	
ELECTRICAL CHARACTERISTICS					
Input Voltage					See INPUT OVER VOLTAGE SHUTDOWN Application Section
Continuous	-40		40	V	
Transient (1 s, Rs* = 0 Ω)	-50		50	V	
Transient (≤ 100 ms, Rs* = 0 Ω)	-50		100	V	
Transient (≤ 1 s, Rs* = 0 Ω)	-50		210	V	
Under-Voltage Lockout					
Turn-On Input Voltage Threshold	14.0	15.5	16.0	V	
Turn-Off Output Voltage Threshold		5.8		V	Iout = 40A
Zero Load Input Current		25		mA	
Standby Mode Input Current		12		mA	
Output Voltage (continuous)	Vout = Vin - (Iin x Rdc) - Vsr			V	
Output Current (continuous)			40	A	Vin = 16V, See Figure C
Output Power (continuous)			600	W	See Figure C & F
DC Resistance (Rdc)					
Tcase = 25°C			28.1	mΩ	
Tcase = 100°C			32.5	mΩ	
Synchronous Rectifier Drop (Vsr)		100		mV	
Power Dissipation (40A output current)					Vin = 16V
Tcase = 25°C			45	W	
Tcase = 100°C			52	W	
Maximum Output Capacitance	0		2.0	mF	See Note 4
Soft-Start Circuitry					
Output current During Soft-Start	0		4	A	See Note 3
Soft-Start Duration Period			20	ms	
Soft-Start Recycle Period		600		ms	
Anti-Parallel Diode					
Forward Current					
Continuous			2.00	A	
Transient (≤ 8 ms)			12.5	A	
Forward Voltage (@ 1 A)	0.60		1.00	V	
Total Differential-Mode Capacitance		157		μF	Measured across input and output pins
Total Common-Mode Capacitance		0.15		μF	Measured between any pin to common-mode pin
Bulk Capacitor		125		μF	
Damping Resistor		0.1		Ω	
Noise Attenuation					See Figure 1

* Rs = Source Impedance



MCOTS-F-28-T-HE

Current: 40A

Technical Specification

MCOTS-F-28-T-HE ELECTRICAL CHARACTERISTICS (Continued)

Parameter	Min.	Typ.	Max.	Units	Notes & Conditions
Specifications subject to change without notice					
Vin=28V DC ±5%, 25°C, Pout=600W unless otherwise specified					
INPUT VOLTAGE SPIKE SUPPRESSION					
Output Voltage Deviation due to a Spike					See Note 2
Input Voltage Spike (Centered on Vin)					
±250V, 100µs, Emax = 15mJ	-10		15	ΔV	MIL-STD-1275 (B, D)
±200V, 10µs, Rs* ≤ 0.5Ω	-10		15	ΔV	MIL-STD-461C (CS06); DEF-STAN 61-5
±400V, 5µs, Rs* ≤ 0.5Ω	-10		15	ΔV	MIL-STD-461C (CS06)
±600V, 10µs, Rs* = 50Ω	-10		15	ΔV	RTCA/DO-160E
INPUT VOLTAGE SURGE SUPPRESSION					
Output Voltage During a Surge					
Input Surge Voltage and Duration					See Note 1
60 V, 550 ms, Rs* = 0 Ω			50	V	MIL-HDBK-704A
80 V, 100 ms, Rs* = 0 Ω			50	V	MIL-HDBK-704A; RTCA/DO-160E
100 V, 80 ms, Rs* = 0 Ω			50	V	MIL-STD-1275 (B, D); DEF-STAN 61-5 (Part 6)/5
110 V, 5 ms, Rs* = 0 Ω	0		50	V	DEF-STAN 61-5 (Part 6)/5
202 V, 350 ms, Rs* = 0 Ω	0		50	V	MIL-STD-1275 (B, D); DEF-STAN 61-5 (Part 6)/6
ISOLATION CHARACTERISTICS					
Isolation Voltage (any pin to common-mode pins)					
Continuous	-2250		2250	V	
Isolation Resistance (any pin to common-mode pins)	30			MΩ	
FEATURE CHARACTERISTICS					
ON/OFF Input					
Off-State Voltage	2		50	V	
Off-State Pin Leakage Current			20	µA	Imax drawn from pin allowed, module off
On-State Voltage	-0.5		0.8	V	
On-State Voltage Pulldown Current	80			µA	Current drain required to ensure logic low
Pull-Up Voltage	3.2	4	4.5	V	See Figure A
ON/OFF Output					
Off-State Resistance			17	Ω	
Off-State Voltage	-100			mV	
On-State Voltage			50	V	
On-State Leakage Current			20	µA	
Standby Input					
Normal-State Voltage	0		3.5	V	
Standby-State Voltage	4		5	V	
Pull-Up Voltage		5		V	
Pull-Up Resistance		50		kΩ	
RELIABILITY CHARACTERISTICS					
Calculated MTBF (MIL-STD-217F2)					
GB @ Tcase = 70°C		4.57		10 ⁶ Hrs.	
GM @ Tcase = 70°C		0.59		10 ⁶ Hrs.	
WEIGHT CHARACTERISTICS					
Device Weight		130		g	

Electrical Characteristics Notes

1. Though beyond the continuous input voltage rating for MCOTS-28 Series Converters, these are within their transient input voltage ratings.
2. Verified by qualification testing and analysis.
3. Soft start is engaged only when the output voltage starts from zero or dips below the Turn-Off Output Voltage Threshold (4V max).
4. Max output capacitance should be selected according to $I_{max} \leq (C_{bulk} + C_{external}) * dv/dt$ where I_{max} is the transient current limit as per shown in Figure C.

* Rs = Source Impedance



Technical Specification

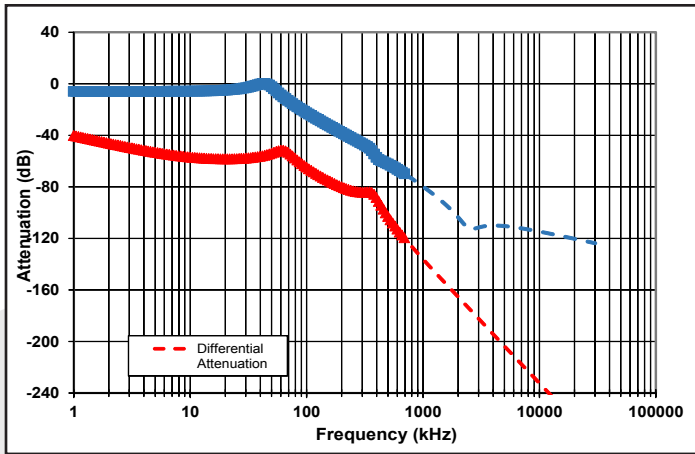

Figure 1: Calculated Common Mode and Differential Mode Attenuation provided by the filter as a function of frequency assuming no other parasitic coupling in the system. Both input lines are assumed to be connected to chassis ground through 50Ω resistors. The common-mode connection is also assumed to be connected to chassis ground.

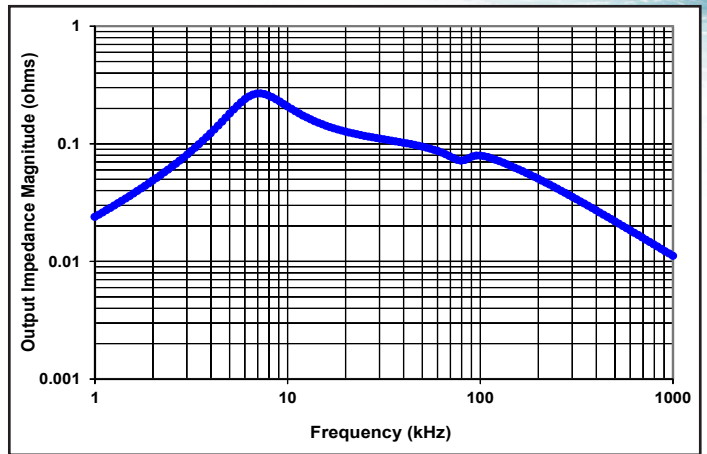

Figure 2: Typical Output Impedance (magnitude) of the filter looking back into its output pins with the input pins connected to a source with zero source impedance.



MCOTS-F-28-T-HE
Current: 40A

Technical Specification

BASIC OPERATION AND FEATURES

The MCOTS-F-28-T is a multi-stage differential-mode and common-mode passive EMI filter designed to interface a power source with one or more SynQor DC-DC converters (or other loads that create EMI). Each stage of this filter is well damped to avoid resonances and oscillations, and only temperature stable multi-layer ceramic capacitors are used. Figure 1 shows the typical differential and common-mode attenuation provided by this filter when the source impedance is 50Ω to chassis ground on each input line.

The MCOTS-F-28-T EMI filter includes a large bulk capacitor with a series damping resistor to correct for the unstabilizing effect of a converter’s negative input resistance. A white paper discussing this negative input resistance and the need for corrective damping can be found on the SynQor website (see Input System Instability application note). Figure 2 shows the magnitude of the filter’s output impedance when the filter input is connected to a stiff voltage source.

When used with SynQor’s DC-DC converters, the MCOTS-F-28-T EMI filter is designed to pass all the relevant MIL-STD-461D/E requirements to their most stringent limits. The MIL-STD-461 Compliance Matrix Table lists these requirements and describes the setup used to pass them. Figures 3 - 6 show results from selected conductive and radiated emissions tests.

TRANSIENT SUPPRESSION: The input voltage surge and spike compliance matrix displays the worst case requirements listed in various 28V Military (Vehicle and Aircraft) and Civil Aircraft standards. The MCOTS-F-28-T EMI filter is designed to handle all of the short duration voltage spike requirements of these standards (with certain assumptions regarding DEF-STAN 61-5). Some of the long duration voltage surge requirements remain within the 50V maximum transient rating of a SynQor MCOTS-C-28 DC-DC converter. The others require the transient suppression circuitry of the MCOTS-F-28-T EMI filter to protect the converter from an over-voltage condition. If MCOTS-C-28E or MCOTS-C-28VE converters are used, voltage surges as high as 80V can be tolerated without the need for this transient suppression circuitry.

The MCOTS-F-28-T EMI filter is also designed to pass the waveform types and applications specified in RTCA/DO-160E Section 22 (Lightning Induced Transient Susceptibility) to Level 4.

REVERSE POLARITY PROTECTION: The MCOTS-F-28-T EMI filter has a series-connected MOSFET that is controlled to function as a diode, but with a very small forward voltage drop ($\leq 4 \text{ m}\Omega \times I_{out}$). This “Synchronous Rectifier” blocks reverse current flow if the filter’s input voltage is mistakenly connected with the wrong polarity. The anti-parallel diode, working with the synchronous rectifier, ensures that the filter’s output voltage goes only slightly negative during this time, and therefore satisfying the minimum input voltage specifications of SynQor’s MCOTS converters.

The synchronous rectifier also performs a useful function during negative polarity spikes and surges, and during brief power interrupts. Since it stops current from flowing negatively through the EMI filter back toward the source, the synchronous rectifier allows the total bulk capacitor (located both within and external to the filter) to better hold up the output voltage during these transients.

ON/OFF: The MCOTS-F-28-T filter has enable pass-through circuitry that bridges an enable signal across the filter’s common-mode impedance. The ON/OFF INPUT pin (pin B) is referenced with respect to the filter’s INPUT RETURN (pins 3 and 4). The ON/OFF OUTPUT pin (pin 8) is referenced with respect to the filter’s OUTPUT RETURN (pin 5). The INPUT RETURN and OUTPUT RETURN may have a different voltage due to common-mode noise and transients.

NOTE: During the time that the MCOTS-F-28-T filter is in its Soft-Start mode the ON/OFF OUTPUT will be held at a logic low. This is done so that all of the filter’s loads can be disabled by this signal during the Soft-Start period. Once the Soft-Start is completed, ON/OFF OUTPUT will follow the state commanded by the ON/OFF INPUT.

Figure A shows the equivalent circuit looking into ON/OFF INPUT. The ON/OFF INPUT pin must be pulled High or left floating to turn an MCOTS converter off. It must be pulled low to turn the converter on.

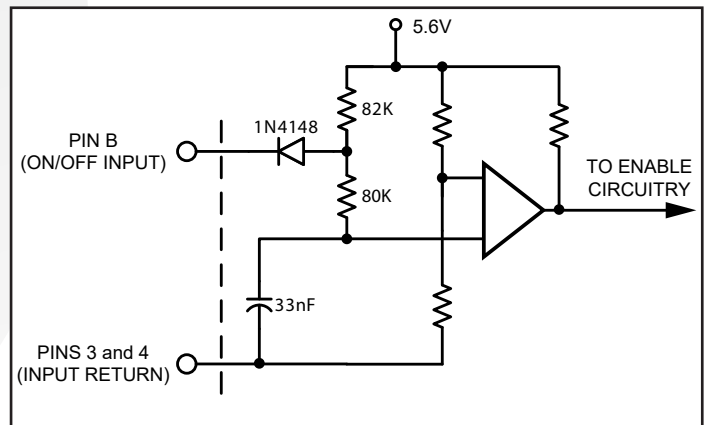

Figure A: Equivalent circuit looking into the ON/OFF INPUT pin with respect to the INPUT RETURN pin.

Figure B shows the equivalent circuit looking into ON/OFF OUTPUT. The n-channel MOSFET in this circuit turns on when power is applied to the filter and ON/OFF INPUT is high. Otherwise, the MOSFET is off. Standard MCOTS converters are enabled when their ON/OFF pin is held low. To interface the enable output of the MCOTS-F-28-T filter with MCOTS converters, add a N-type MOSFET as shown in the typical connection diagram. For improved noise tolerance, a separate MOSFET can be used for each MCOTS converter, with their gates isolated from each other with sense resistors.



Technical Specification

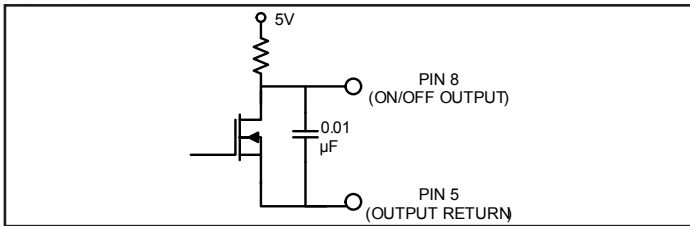

Figure B: Equivalent circuit looking into the ON/OFF OUTPUT pin with respect to the OUTPUT RETURN pin.

If the enable pass-through circuit is not being used, the ON/OFF INPUT pin may be left open or connected to the INPUT RETURN pins.

SOFT-START: The MCOTS-F-28-T filter incorporates Soft-Start circuitry to limit the amount of current drawn from the power source by the charging of large bulk capacitors at the filter's output.

Once the input voltage exceeds the turn-on threshold value, the Soft-Start circuitry controls the filter's output current to be approximately 4A. This mode of operation continues until the filter's output voltage reaches the input voltage, at which time the filter is able to deliver its rated output current. If after the Soft-Start duration period the filter's output has not risen to the input voltage, then the filter will disconnect the output from the input, wait for a time equal to the Soft-Start recycle period, and initiate a new Soft-Start.

Since, during Soft-Start, the filter will deliver only 4A to its output, it is important to limit the load current so that the total bulk capacitance can be fully charged before the Soft-Start duration period is over. To facilitate this, the filter's ON/OFF OUTPUT pin is held low during the Soft-Start mode. This signal can therefore be used to disable the filter's loads during this time. Once the Soft-Start mode is completed, ON/OFF OUTPUT will follow ON/OFF INPUT.

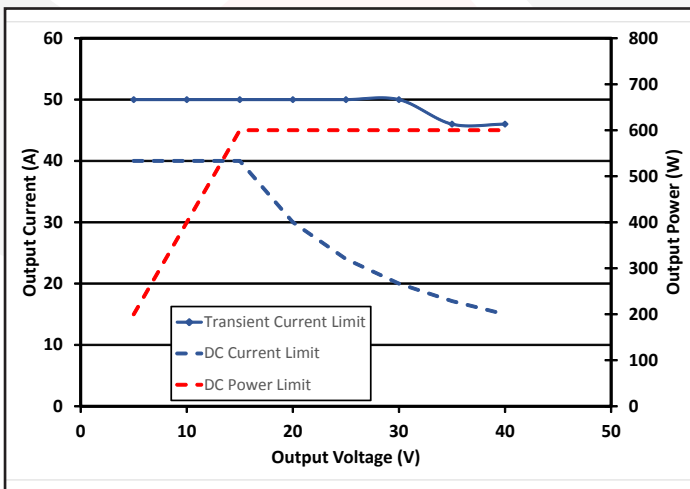

Figure C: Output Power / Current Limit as a function of Output Voltage.

OUTPUT POWER LIMIT: The filter has this feature to limit the maximum power that it can deliver during steady state (DC) or transients and to also protect itself from short circuit at its output pins. During steady state or transients if the filter exceeds the current limit as shown in Figure C the filter will shut down and reinstitute a soft start cycle in 600ms. Figure C shows the output power limit threshold as a function of output voltage and Figure F shows the power limit based on baseplate temperature.

STANDBY: The MCOTS-F-28-T filter has standby circuitry that minimizes the power drawn from the filter's input power source when the standby feature is activated.

It does this in two ways. First, the output of the filter is disconnected from the input so that there will be no power drawn by downstream converters or other loads. Second, the active circuitry within the filter is placed into a reduced power consumption mode. The net result is a current draw of only about 2mA from a 28V input power source.

Figure D shows the equivalent circuit looking into the STANDBY pin (pin 6).

This pin is referenced with respect to the filter's OUTPUT RETURN pin (pin 5). It should be pulled low to have the filter operate in its normal mode. If the pin is instead left open-circuit and pulled high by its internal circuitry, the standby feature will be activated.

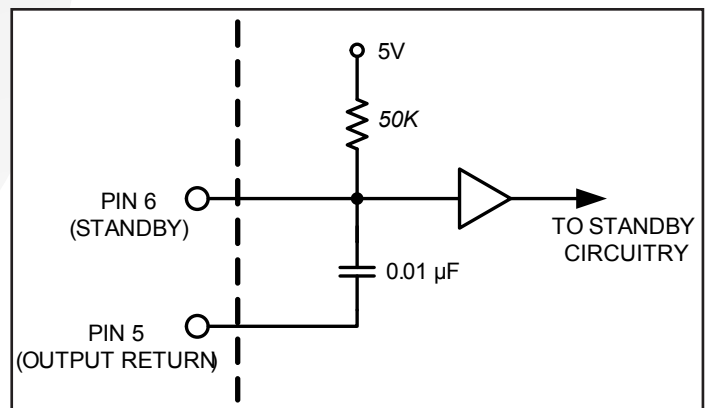

Figure D: Equivalent circuit looking into the STANDBY pin with respect to the OUTPUT RETURN pin.



Application Note: A typical application would place the MCOTS filter close to the input of the DC-DC converter, with the cases of the filter and the converter connected together through a ground plane. Both cases are electrically conductive, so connection to the cases can be made with the fasteners used to secure the device.

Do not connect the outputs of multiple MCOTS-F-28-T filters in parallel. Connecting filters in this manner may result in slightly unequal currents to flow in the positive and return paths of each filter. These unequal currents may cause the internal common-mode chokes to saturate and thus cause degraded common-mode rejection performance.

INPUT OVER VOLTAGE SHUTDOWN: To protect itself from damage due to sustained excessive power dissipation, the filter will shut down if the input voltage versus time exceeds the envelope in Figure E.

During this shutdown, power flow to the load is interrupted and the filter's ON/OFF OUTPUT pin is pulled LOW. When the input voltage returns to normal limits (and a Soft-Start Recycle Period has elapsed), the filter automatically begins a Soft-Start cycle.

All of the surges listed in the VOLTAGE SURGE AND SPIKE COMPLIANCE MATRIX on page 11 fall below the Figure E envelope. Only the DEF STAN 61-5 (Part 6)/6 DIT08.B surge exceeds this envelope. During a DIT08.B surge the filter will shutdown and then automatically restart once the surge passes. This meets the requirements of DEF STAN 61-5 (Part 6)/6 at Performance Criterion C while the DIT08.B test requires only Performance Criterion D.

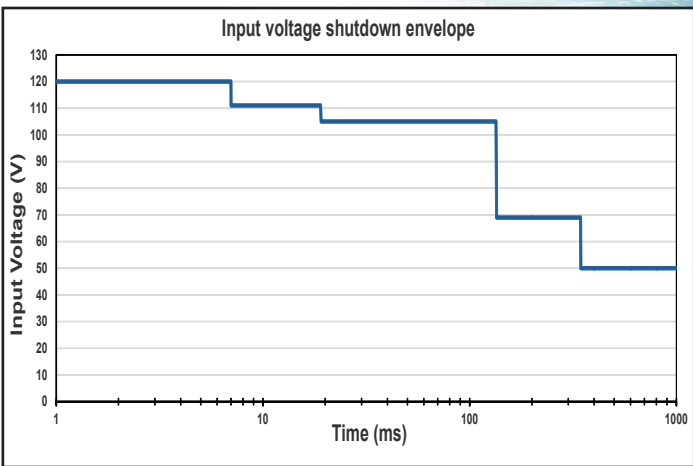

Figure E: Input Over Voltage shutdown envelope as function of time.

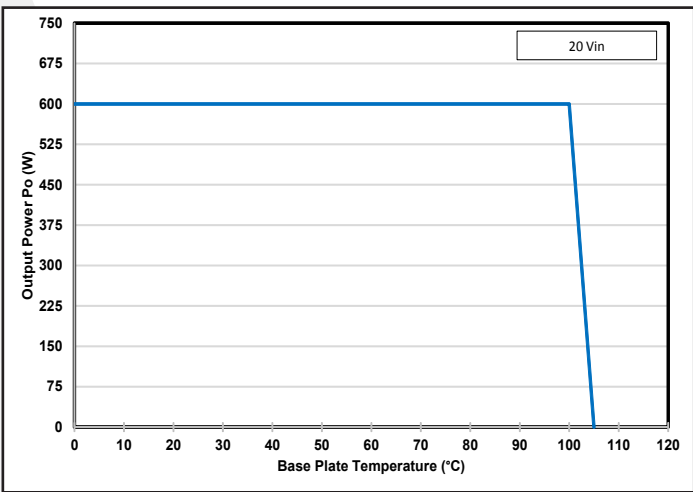
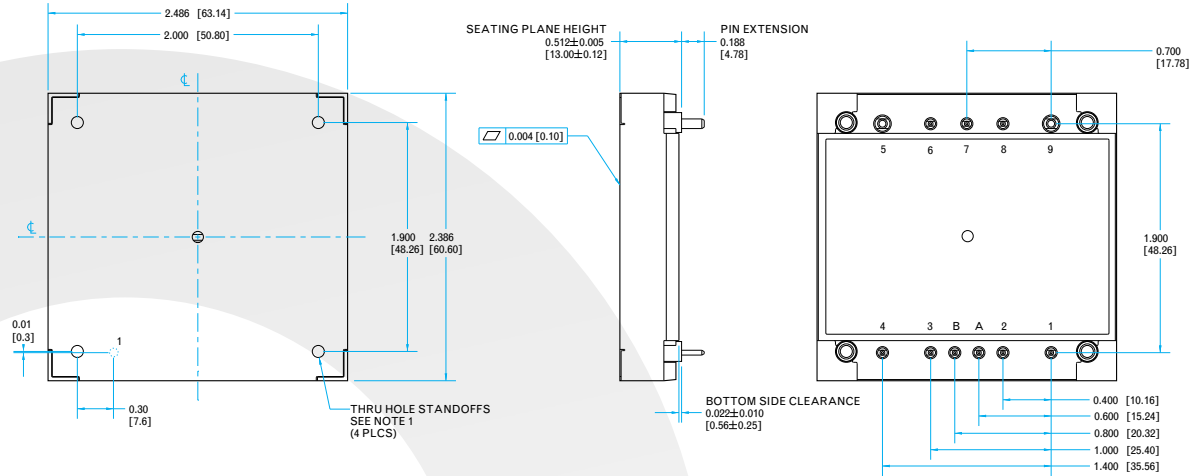

Figure F: Power vs. baseplate temperature.



Technical Specification

Mechanical Drawing



NOTES

- Applied torque per M3 screw should not exceed 6in-lb (0.7 Nm). For non-threaded standoffs, internal diameter 0.125" (3.18 mm)
- Baseplate flatness tolerance is 0.004" (0.10mm) TIR for surface.
- Pins 1-4,6-8, A, and B are 0.040" (1.02mm) diameter, with 0.080" (2.03mm) diameter standoff shoulders.
- Pins 5 and 9 are 0.080" (2.03 mm) diameter with 0.125" (3.18 mm) diameter standoff shoulders.
- All Pins: Material – Copper Alloy; Finish – Matte Tin over Nickel plate
- Undimensioned components are shown for visual reference only.
- Weight: 4.9 oz. (140 g) typical
- Threaded or Non-Threaded options available
- All dimensions in inches (mm)
Tolerances: x.xx +/-0.02 in. (x.x +/-0.5mm)
x.xxx +/-0.010 in. (x.xx +/-0.25mm)
- Workmanship: Meets or exceeds IPC-A610 Class II

PIN DESIGNATIONS

Pin	Label	Name	Function
1	+Vin	Vin(+)	Positive input voltage
2	+Vin	Vin(+)	Positive input voltage
A	COM IN	COM IN	Input-side common-mode
B	ON/OFF IN	ON/OFF IN	Input on/off
3	IN RTN	Vin(-)	Input return
4	IN RTN	Vin(-)	Input return
5	OUT RTN	Vout(-)	Output return
6	STDBY	STDBY	Standby
7	COM OUT	COM OUT	Output-side common-mode
8	ON/OFF OUT	ON/OFF OUT	Output on/off
9	+Vout	Vout(+)	Positive output voltage

Flanged Mechanical Drawing

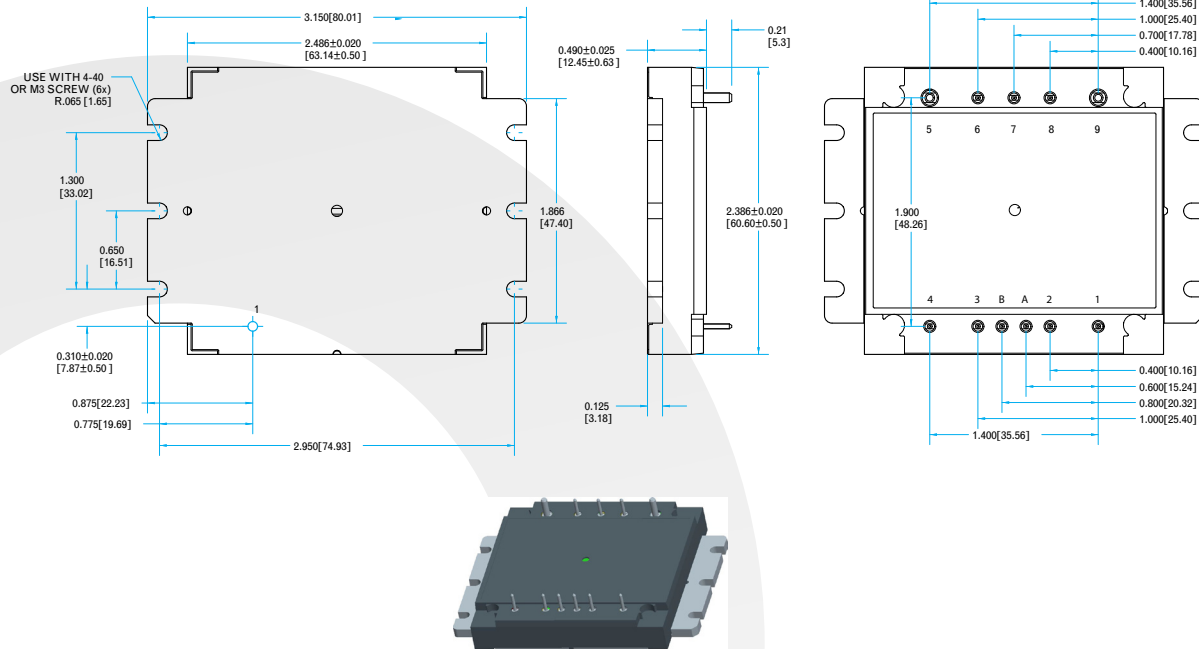

NOTES

- 1) Applied torque per M3 or 4-40 screw should not exceed 6in-lb (0.7 Nm).
- 2) Baseplate flatness tolerance is 0.010" (0.25mm) TIR for surface.
- 3) Pins 1-4,6-8, A, and B are 0.040" (1.02mm) diameter, with 0.080" (2.03mm) diameter standoff shoulders.
- 4) Pins 5 and 9 are 0.080" (2.03 mm) diameter with 0.125" (3.18 mm) diameter standoff shoulders.
- 5) All Pins: Material – Copper Alloy; Finish – Matte Tin over Nickel plate
- 6) Undimensioned components are shown for visual reference only.
- 7) Weight: 5.2 oz. (146 g) typical
- 8) All dimensions in inches (mm)
Tolerances: x.xx +/-0.02 in. (x.x +/-0.5mm)
x.xxx +/-0.010 in. (x.xx +/-0.25mm)
- 9) Workmanship: Meets or exceeds IPC-A610 Class II

PIN DESIGNATIONS

Pin	Label	Name	Function
1	+Vin	Vin(+)	Positive input voltage
2	+Vin	Vin(+)	Positive input voltage
A	COM IN	COM IN	Input-side common-mode
B	ON/OFF IN	ON/OFF IN	Input on/off
3	IN RTN	Vin(-)	Input return
4	IN RTN	Vin(-)	Input return
5	OUT RTN	Vout(-)	Output return
6	STDBY	STDBY	Standby
7	COM OUT	COM OUT	Output-side common-mode
8	ON/OFF OUT	ON/OFF OUT	Output on/off
9	+Vout	Vout(+)	Positive output voltage



MCOTS-F-28-T-HE
Current: 40A

Technical Specification

VOLTAGE SURGE AND SPIKE COMPLIANCE MATRIX

These tables show the Voltage Surge and Spike requirements/limits that have been met* by a stand-alone setup comprised of:

- MCOTS-F-28-P (or -T) Filter
- MCOTS-C-28-05-QT (or -HP) DC-DC Converter
- Resistive Load
- Metal Chassis Plane

Vehicle 28Vin	Part	Worst Case Over-Voltage Surge (Voltage/Duration)	Short Duration Spikes (Voltage/Duration/Impedance)
MIL-STD-1275D	(Gen. + Bat.)	40V / 50ms	±250V / 15mJ / 0.5Ω
	(Bat. only)	100V / 50ms	
	(Gen. only)	100V / 50ms	
DEF STAN 61-5 (PART 6)/5†	(Gen. + Bat.)	40V / 50ms	+130V to -100V max§ +90V to -60V / 10µs§
	(Bat. Only)	+70V to -40V / 5ms§	
	(Bat. Only, Non-Regen. Ld. Sw.)	+70V to -40V / 5ms§	
	(Bat. Only, Regen. Ld. Sw.)	80V / 80ms§	
	(Gen. only)	40V / 50ms	
DEF STAN 61-5 (PART 6)/6†	DIT08.B**, DIT07.B	80V / 80ms§ 100V / 50ms +110V to -50V / 5ms§	+280V to -220V max§ +130V to -70V / 10µs§
	DET03.A	+174V / 350ms	
	DET04.A	40V / 50ms§	
	DIT04.A**	+70V to -40V / 1ms§ +110V / 300ms§	

Aircraft 28Vin	Part	Worst Case Over-Voltage Surge (Voltage/Duration)	Short Duration Spikes (Voltage/Duration/Impedance)
MIL-HDBK-704-8	(704A)	80V / 50ms	N/A
	(704B, C, D, E, F)	60V / 550ms	
	(Cat A)	50V / 50ms	
RTCA/DO-160E	(Cat A)	47V / 100ms	±600V / 10µs / 50Ω
	(Cat B)	38V / 1s	
	(Cat B)	60V / 100ms	±200V / 10µs / 50Ω
	(Cat B)	40V / 1s	
	(Cat C)	80V / 100ms	N/A
(Cat C)	48V / 1s		

Met by any MCOTS Filter	Met by an MCOTS Filter having the Transient Suppression and Reverse Polarity Protection Features
-------------------------	--------------------------------------------------------------------------------------------------

* Surge/spike requirements/limits are deemed to have been met as long as transient deviations in the converter's output voltage remain within ±10% of its initial value.

** MCOTS-F-28-T filter only: Performance Criteria C. Filter will shut down and then automatically restart when the voltage returns to normal limits.

§ These are defined as the maximum disturbances that equipment can inflict upon the power system, not as disturbances imposed upon utilization equipment. To ensure compatibility, however, these are within the designed stress envelope of the indicated filters & converters.

† For the DEF STAN 61-5 specification:

- 1) Negative surges require reverse voltage protection circuitry to protect the converter (but not the filter) from a negative input. This circuitry is included in the MCOTS-F-28-T but not the MCOTS-F-28-P filter.
- 2) The negative surges may cause the converter to shut down unless additional holdup capacitance is included.
- 3) Maximum spike voltages are assumed to last <1µs



Technical Specification

MCOTS-F-28-T-HE
Current: 40A

MIL-STD-461 COMPLIANCE MATRIX

This table shows the MIL-STD-461 requirements/limits that have been met* by a stand-alone setup comprised of:

- MCOTS-F-28-T-HP Filter
- MCOTS-C-28-12-HZ DC-DC Converter
- 500W Resistive Load
- Metal Chassis Plane

	-461D/E	
	Requirement	Most Stringent Limit Listed
Conducted Emissions	CE101 CE102	Submarine Basic Curve
Conducted Susceptibility	CS101 CS114 CS115 CS116	Curve #2 Curve #5 Basic Waveform $I_{MAX} = 10A$
Radiated Emissions	RE101 RE102†	Navy Fixed Wing Internal, >25 meters Nose-to-Tail

* Susceptibility requirements/limits are deemed to have been met as long as transient deviations in the converter's output voltage remain within $\pm 10\%$ of its initial value

† Met with common-mode capacitors and a metal screen shield covering the filter, converter, and resistive load.



MCOTS-F-28-T-HE
Current: 40A

Technical Specification

Mil-COTS Qualification

Test Name	Details	# Tested (# Failed)	Consistent with MIL-STD-883F Method
Life Testing	Visual, mechanical and electrical testing before, during and after 1000 hour burn-in @ full load	15 (0)	Method 1005.8
Shock-Vibration	Visual, mechanical and electrical testing before, during and after shock and vibration tests	5 (0)	MIL-STD-202, Methods 201A & 213B
Humidity	+85 °C, 95% RH, 1000 hours, 2 minutes on / 6 hours off	8 (0)	Method 1004.7
Temperature Cycling	500 cycles of -55 °C to +100 °C (30 minute dwell at each temperature)	10 (0)	Method 1010.8, Condition A
Solderability	15 pins	15 (0)	Method 2003
DMT	-65 °C to +110 °C across full line and load specifications in 5 °C steps	7 (0)	
Altitude	70,000 feet (21 km), see Note	2 (0)	

Note: A conductive cooling design is generally needed for high altitude applications because of naturally poor convective cooling at rare atmospheres.

Mil-COTS Converter and Filter Screening

Screening	Process Description	S-Grade	M-Grade
Baseplate Operating Temperature		-55 °C to +100 °C	-55 °C to +100 °C
Storage Temperature		-65 °C to +135 °C	-65 °C to +135 °C
Pre-Cap Inspection	IPC-A-610, Class III	•	•
Temperature Cycling	MIL-STD-883F, Method 1010, Condition B, 10 Cycles		•
Burn-In	100 °C Baseplate	12 Hours	96 Hours
Final Electrical Test	100%	25 °C	-55 °C, +25 °C, +100 °C
Final Visual Inspection	MIL-STD-883F, Method 2009	•	•

STANDARDS COMPLIANCE

Parameter	Notes & Conditions
STANDARDS COMPLIANCE	
	Pending
UL 62368-1	Basic Insulation
CAN/CSA C22.2 No. 62368-1	
EN 62368-1	

Note: An external input fuse must always be used to meet these safety requirements.
 Contact SynQor for official safety certificates on new releases or download from the SynQor website.



MCOTS-F-28-T-HE
Current: 40A

Technical Specification

Ordering Information/ Part Numbering

Family	Product	Input Voltage	Filter Type	Package	Thermal Design	Screening Level
MCOTS	F: Filter	28: -40V to +40V	P: Passive T: Transient	DM: Demi Brick	N: Normal Threaded D: Normal Non-Threaded F: Flanged	S: S-Grade M: M-Grade
		28E: -70V to +70V		QT: Quarter Brick Tera		
		48: -80V to +80V		HT: Half Brick Tera		
		270: -500V to +500V		HP: Half Brick Peta HE: Half Brick Exa		

Not all combinations make valid part numbers, please contact SynQor for availability. See the Product Summary web page for more options.

Example MCOTS-F-28-T-HE-N-S

Application Notes

A variety of application notes and technical white papers can be downloaded in pdf format from our website.

Contact SynQor for further information and to order:

Phone: 1 -(603) 541-4141 **Web:** www.synqor.com
E-mail: power@synqor.com
Address: 9 Northeastern Blvd., Suite 200, Salem, NH 03079 USA

Warranty

SynQor offers a two (2) year limited warranty. Complete warranty information is listed on our website or is available upon request from SynQor.

PATENTS

SynQor holds numerous U.S. patents, one or more of which apply to most of its power conversion products. Any that apply to the product(s) listed in this document are identified by markings on the product(s) or on internal components of the product(s) in accordance with U.S. patent laws. SynQor's patents include the following:

- 7,765,687 7,787,261
- 8,149,597 8,644,027