

MILITARY FIELD-GRADE UNINTERRUPTIBLE POWER SUPPLY

1500 VA / 1250 W Output Power	102 V (L-L) - 156 V (L-L) 59 V (L-N) - 90 V (L-N) 3-Phase Delta; 45 - 65 Hz AC Input Voltage	115 Vrms or 230 Vrms 50 Hz, 60 Hz or 400 Hz AC Output Voltage Options	28 Vnom DC Input Voltage Option	500 W or 1250 W DC Output Voltage Option	>10/13.5/16 min. - 1U Battery Run Time Options
--------------------------------------	---	--	--	---	--

Sealed Construction, Ultra Low Weight, Compact Size



N+M REDUNDANCY
(optional)

DESIGNED & MANUFACTURED IN USA

SynQor's Military Field-Grade Uninterruptible Power Supply units are designed for the extreme environmental and demanding electrical conditions of Military/Aerospace applications. SynQor's UPS incorporates field proven high efficiency designs and rugged packaging technologies. This UPS will accept a wide range of input voltage and frequency values while delivering a well-conditioned AC output to the load. Up to three units can be combined to provide higher power, higher voltage and/or multiple output phases. The use of lithium ion batteries permits the lowest profile and lowest weight solution in its power class. It is designed to comply with a wide range of military standards. Options include a 500 W or single 1250 W DC output, a DC input rated for military 28 VDC sources, and an electronic breaker on the AC output provides fault-tolerant parallel operation for higher power and/or N+M redundancy.

Combine units for Higher Power, Voltage, 3-Phase AC output, and/or Redundancy

Features

- Sealed, weather-proof, shock-proof construction
- Hot swappable internal battery pack (lithium ion)
- >10 minute run-time at full power
- 1250 W (1500 VA) output power
- Full power operation: -20°C to +55°C
- 3 Phase AC input: 102-156 Vrms (L-L) / 59-90 Vrms (L-N)
- Wide range AC input frequency: 45 - 65 Hz
- Power factor correction at AC input
- Dual input (AC and optional DC)
- True on-line double conversion
- Cold start with no AC or DC input connections
- Pure sinusoidal AC output voltage
- Handles 0.0–1.0 power factor loads and non-linear loads
- Up to 3 units can be combined for higher power, voltage or a 3-Phase AC output
- Up to 32 units can be combined to form a higher power fault-tolerant, glitch-free system, perhaps with N+M redundancy, by ordering with the "AC Output Electronic Breaker" option and the appropriate configuration cable
- User I/O and Configuration signal ports
- 1U high rack mount unit (17.00"W x 22.53"D x 1.73"H)
- Low weight: 33 lbs. (including battery)

Options

- DC input (28 Vnom) for dual source
- UPS-1500-H-1U > 13.5 minutes of run-time
- UPS-1500-M-1U > 16 minutes of run-time and -40°C operation
- 115 Vrms or 230 Vrms AC output
- 50 Hz, 60 Hz, or 400 Hz output
- DC1: Auxiliary isolated DC output (up to 500 W)
- DC2: High power DC output (up to 1250 W) parallelable for higher power
- Shipboard version with floating neutral wire

Specification Compliance

This UPS is designed to meet:

- MIL-STD-1399-300-1 - Shipboard AC Power Requirements
- MIL-STD-810G - Environmental Engineering Considerations
- MIL-STD-461G - Electromagnetic Interference

Contents

Technical Specification.....	2
Application Section.....	5
Mechanical Diagrams.....	8
Ordering Information.....	10



Technical Specification

INPUT CHARACTERISTICS

Operating AC Input

Voltage Continuous	102 - 156 Vrms (L-L)
	59 - 90 Vrms (L-N)
3-Phase Connection Type	3-Wire Delta
Frequency	45 - 65 Hz
Power Factor (100% load)	0.999 at 60 Hz
Reactive Power at Input (per phase)	10 VAR at 60 Hz
Maximum Input Current (per phase)	10.8 A (full load, low line)
Internal AC Input Fuse Rating	30 A

Operating DC Input (Optional)

Voltage	22 - 33 Vdc
Continuous Maximum Input Current	62 A (full load, 22 Vdc)
Transient Maximum Input Current	75 A

OUTPUT CHARACTERISTICS

Total Output Power Continuous	1250 W (1500 VA)
Maximum DC1 Output Power	510 W
Maximum DC2 Output Power	1250 W

(Note: Available AC power is reduced by power delivered to the DC output)

AC Output

AC Output Waveform	Pure Sinusoidal	
Voltage	115 Vrms ± 3%	230 Vrms ± 3%
Frequency	60 Hz ± 0.5%	50 Hz ± 0.5%
	400 Hz ± 0.5%	
Peak Load Current	26 A (115 Vrms)	13 A (230 Vrms)
Load Power Factor	0 - 1.0 (leading or lagging)	
Total Harmonic Distortion	2% (1000 W resistive load)	

DC1 Output (optional)

Voltage Regulation (Over Load & Temperature) ± 3%		
Common Voltage/Power combinations (DC1)	12 V at 42 A	=504 W
(Other Options Available)	15 V at 34 A	=510 W
	24 V at 21 A	=504 W
	28 V at 18 A	=504 W
	40 V at 12.5 A	=500 W
	50 V at 10 A	=500 W

DC2 Output (optional)

Voltage Setpoint	± 3%	
No Sharing		
Voltage Regulation (Over Load & Temperature) -2%		
Common Voltage/Power combinations (DC2)	24 V at 50 A	=1200 W
	28 V at 44.6 A	=1250 W
	50 V at 20 A	=1000 W

Droop Share (Output droops vs. load to allow passive sharing among modules.)

24 V Option

Voltage Regulation (Over Load & Temperature) -15%		
	26 V at 0 A	
	22 V at 50 A	=1100 W

28 V Option

Voltage Regulation (Over Load & Temperature) -13%		
	30 V at 0 A	
	26 V at 48.1 A	=1250 W

50 V Option

Voltage Regulation (Over Load & Temperature) -10%		
	52 V at 0 A	
	48.5 V at 20.6 A	=1000 W

Specifications subject to change without notice.

ENVIRONMENTAL CHARACTERISTICS MIL-STD-810G

Temperature Methods 501.5, 502.5

Operating Temperature	-20°C — +55°C
Storage Temperature	-40°C — +65°C

Altitude Method 500.5

Operating	0 - 18,000 ft
Non-operating	0 - 40,000 ft

Environmental Tests

Shock/Drop	Method 516.6, Procedures 1,4,6
Temperature Shock	Method 503.5, Procedure 1
Vibration	Method 514.6, CAT 5, 7, 8, 9, 24
Fungus	Method 508.6
Salt Fog	Method 509.5
Sand and Dust	Method 510.5, Procedures 1,2
Rain	Method 506.5, Procedure 1
Humidity	Method 507.5, Procedure 2
Mechanical Vibrations of Shipboard Equipment	Method 528, Procedure 1

RELIABILITY CHARACTERISTICS MIL-HDBK-217F

MTBF	100 kHrs	MIL-217F Ground Benign, Ta=25 °C
------	----------	----------------------------------

ELECTROMAGNETIC EMISSIONS TESTED TO MIL-STD-461G

CE101 (≥ 1 kVA Limit)	Conducted Emissions < 10 kHz
CE102 (115V Limit)	Conducted Emissions > 10 kHz
RE101 (Army & Navy Limits)	Magnetic Field Radiated Emissions
RE102 (Above Deck Limit)	Electric Field Radiated Emissions

LIGHTNING EFFECTS TESTED TO MIL-STD-1399-300-1

Voltage Spikes (1 kV peak)	Section 3.5.9 / 5.3.5
----------------------------	-----------------------

MECHANICAL CHARACTERISTICS

1U (Standard Battery Pack)

Chassis Size (H x W x D)	17.00"W x 22.53"D x 1.73"(1U)
Case Material	Aluminum
Total Weight	33 lbs. (with chassis & battery)

Connectors

AC Input Connector	MS3470L14-4PW
DC Input Connector	MS3470L18-8P
AC Output Connector	MS3470L14-4S
DC1 Output Connector	MS3470L14-4SW
DC2 Output Connector	MS3470L18-8S
User I/O Ports	HD DB15 Female
Configuration I/O Port	HD DB15 Male
Ethernet Port	Amphenol RJF22N00, Code B

Cooling Exhaust Fans

Sound Pressure Level (SPL)	54 dB(A)
Air Flow	0.67(m³/min) 23.7 CFM

Two fans in system, above specs are for each fan separately.

Technical Specification

High Density DB15 Female (15 Pin Connector)

Signal	PIN	Function
TX	2	RS232 DCE Device Transmit
RX	3	RS232 DCE Device Receive
GND	4, 5	Ground reference for all digital inputs and outputs
LOW BATT	6	Open collector output where "low" indicates battery charge level <10%
ACIN GOOD	7	Open collector output where "low" indicates AC Input voltage is within range
+5V	8	Vout with minimal current drive usable as a pull-up voltage for open collector output signals. Load must be <35mA
ON BATT	9	Open collector output where "low" indicates that the UPS is running on battery power.
REMOTE START	12	Drive this line "high" with $\geq 5\text{mA}$ to enable UPS outputs
SHUTDOWN	13	Drive this line "high" with $\geq 5\text{mA}$ to disable UPS outputs
OUT OK	14	Open collector output where "low" indicates AC Output voltage is within range
OVER TEMP	15	Open collector output where "low" indicates that the UPS is at or above its maximum temperature



LITHIUM-ION BATTERY CHARACTERISTICS

UPS-1500-S-1U, BAT-0200 Pack Run Time

1250 W : 10 min	1000 W : 13 min	625 W : 21 min
-----------------	-----------------	----------------

UPS-1500-H-1U, BAT-0400 Pack Run Time

1250 W : 13.5 min	1000 W : 18 min	625 W : 27 min
-------------------	-----------------	----------------

UPS-1500-M-1U, BAT-0400 Pack Run Time

1250 W : 16 min	1000 W : 22 min	625 W : 34 min
-----------------	-----------------	----------------

Recharge Time (to 90% charge)

UPS-1500-[S,H,M]-1U, BAT-0200 or BAT-0400

Total Output Power	< 1000 W	2 hrs
--------------------	----------	-------

Temperature Range for Recharge: 0°C to 45°C

Internal heaters maintain battery temperature above 0°C when input power is present.

Battery charging only enabled below +45°C.

Block Diagram

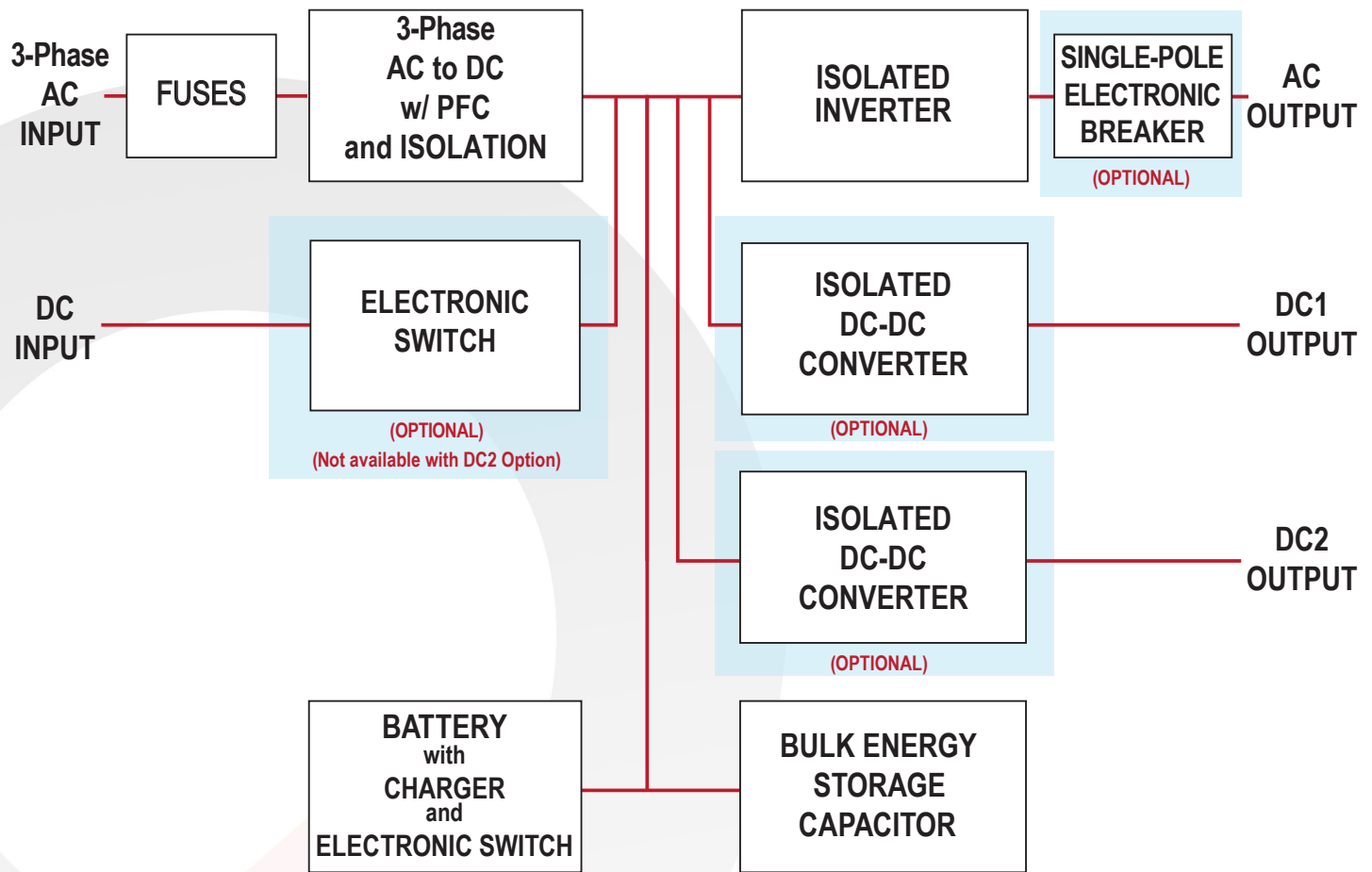

Application Section

“R” Option: AC Output Electronic Breaker

Fault Tolerant, Glitch-Free Operation

The “R” option adds an electronic breaker to the AC output of the UPS to permit fault-tolerant, glitch-free parallel operation. With this option, when several UPS units are connected in parallel at their AC outputs and one unit has an internal fault that might otherwise have pulled down the AC output bus, the electronic breaker will disconnect the failed unit so that the remaining paralleled units can continue to power the bus. This allows the system to be “fault-tolerant”. The disconnect occurs very quickly so that the AC output voltage will remain within its specified parameters as long as the remaining paralleled units can deliver the total load power. This allows the system to continue running “glitch-free”.

The electronic breaker is a single-pole breaker present in the hot-side AC output wire only. The neutral AC output wire is left floating from the UPS chassis to facilitate the paralleling of units into various configurations.

Expanded Paralleling

The “R” option also increases the total number of UPS units that can be paralleled to a maximum of 32. AC output current sharing among the paralleled units is accomplished with a high speed digital configuration cable. The units will share the total load current to within $\pm 2\%$, and for a split-phase or 3-phase system the AC voltages and AC currents will have phase balance within ± 2 degrees.

N+M Redundancy

Besides permitting a higher number of UPS units to be paralleled, the “R” option also makes it possible to set up N+1, or more generally N+M, redundant systems with a total of up to 32 UPS units. In such a system the failure of one unit (or M units) will not cause the overall system to fail. A failed unit can then be replaced to return the redundancy level to its original design. The replacement unit can be inserted into a live, operating system with proper precautions, but for safety reasons it is recommended that the system be turned off first.

Output Power Cable Connection

UPS systems are formed by first connecting the neutral wires of all the individual units together. For single phase systems, the hot wires are also connected together to form a single bank of UPS units. Split-phase systems are formed by connecting the hot output wires into two banks. One bank will have its output voltage phase-shifted 180° from the other. The phase-shift is determined by the configuration cable. Similarly, 3-phase systems are formed by grouping the hot output wires into three banks, each bank having its output voltage phase-shifted by 120° . Again, the phase shift is determined by the configuration cable. Since 3-phase systems are formed by connecting the neutral wires together and phase shifting the hot wires, the AC outputs must be wye-connected to form 3-phase systems. Delta connection of UPS units is not supported. However, once a 3-phase system is formed, loads may be connected as wye or delta.

The diagrams on the following page give examples of how multiple UPS units with the “R” option can be connected to create higher output power single-phase, split-phase, and 3-phase AC systems that will have N+M redundancy as long as N units are sufficient for the maximum load power per phase. Note, again, that the maximum total number of units that can be arranged in any of these configurations is 32.

Configuration Cables

Any system of “R” option UPS units requires a specific configuration cable that defines the arrangement of UPS units in the system. The configuration cable determines the phase shift for split-phase and 3-phase systems. The cable also provides high speed digital communication for current sharing on each phase.

Configuration cables for two parallel units and three parallel units in a single-phase system are available as standard products. Please contact the factory to purchase configuration cables for systems larger than three UPS units, or systems that have split-phase or 3-phase AC outputs.

Configuration cables are required for paralleling the AC output only. DC outputs rely on droop share for paralleling, and do not require a configuration cable. See the “Ordering Information” page for DC output options with droop share that can be placed in parallel.

Application Figures

Single Phase Output System

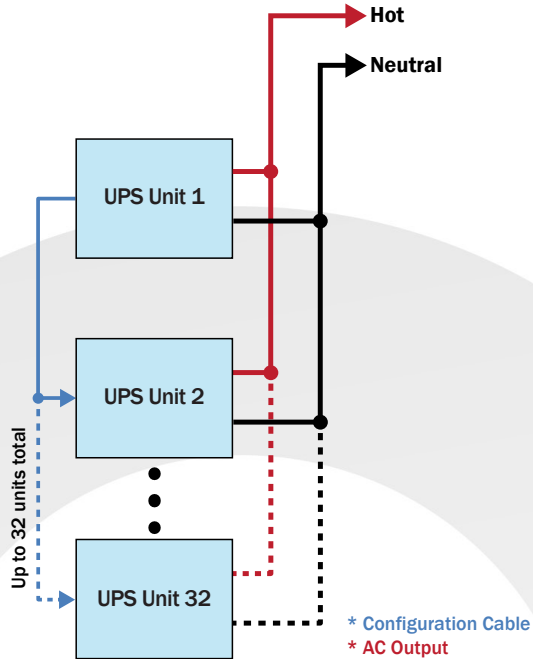

Split Phase Output System

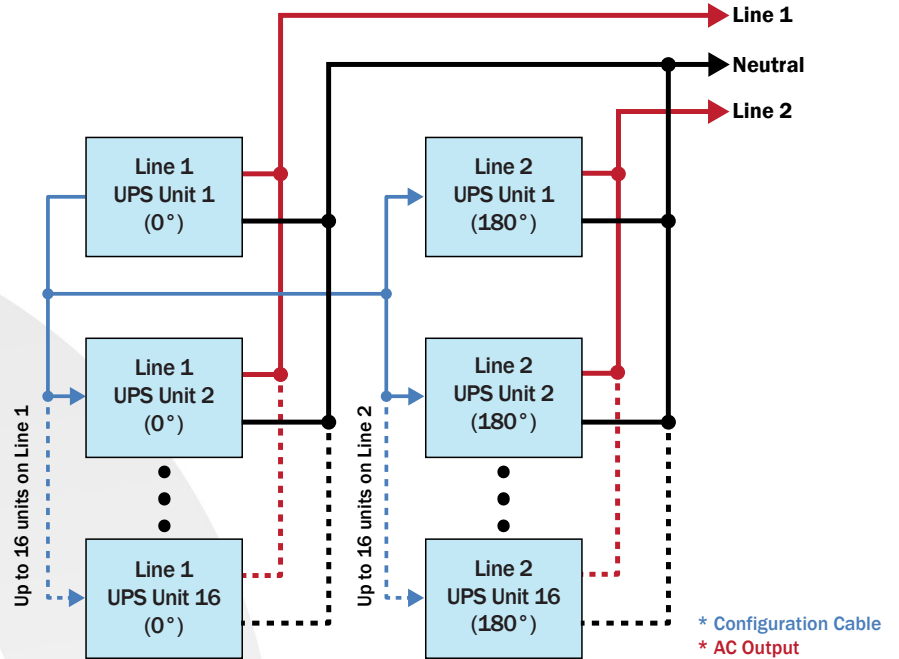

3-Phase Output System (Y - Connection Only)

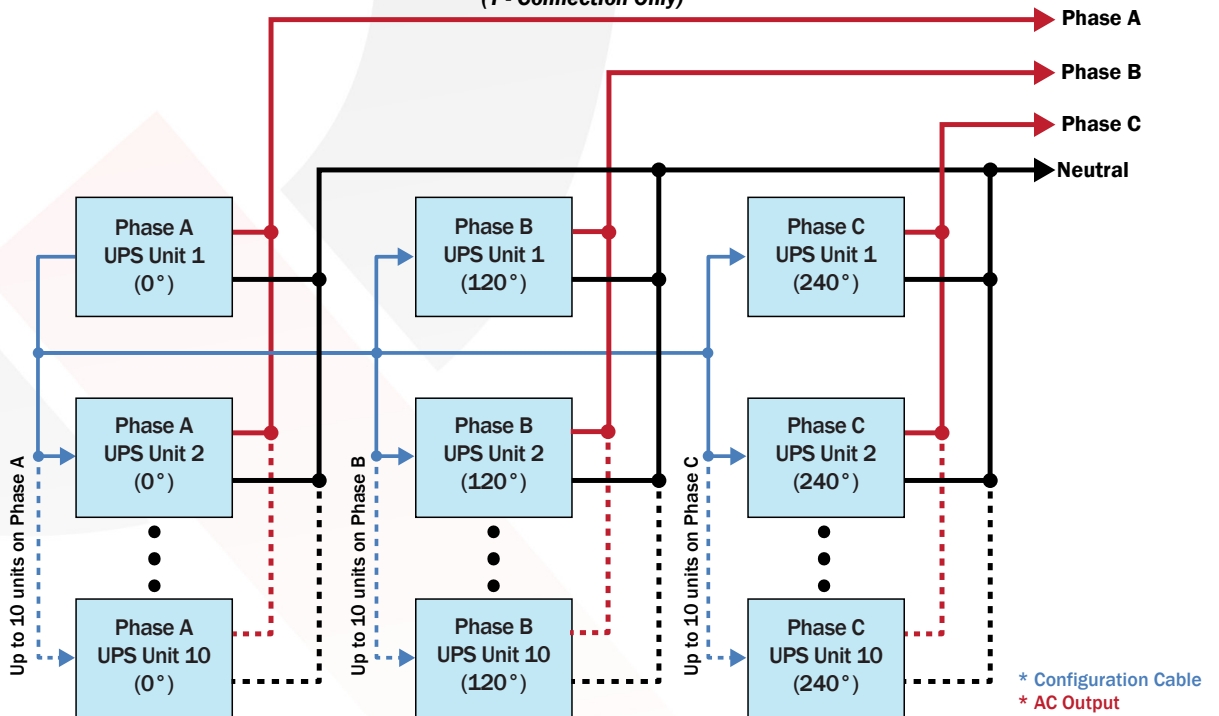

* Contact factory for system specific configuration cables.

Mechanical Features

UPS-1500-[S,H,M]-1U-3

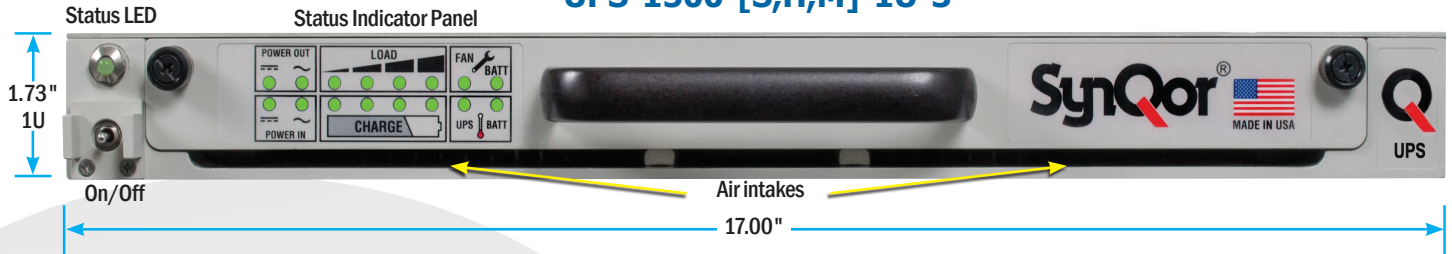

UPS-1500-[S,H,M]-1U-3 with DC Input / DC1 Output Option

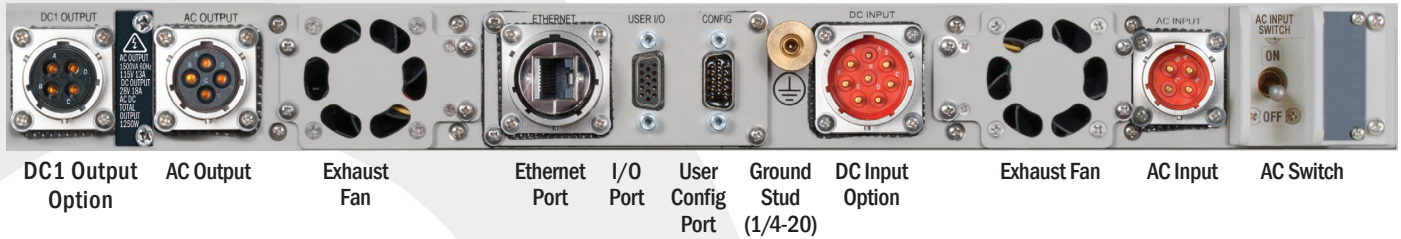

UPS-1500-[S,H,M]-1U-3 with DC1 Output / DC2 Output Option

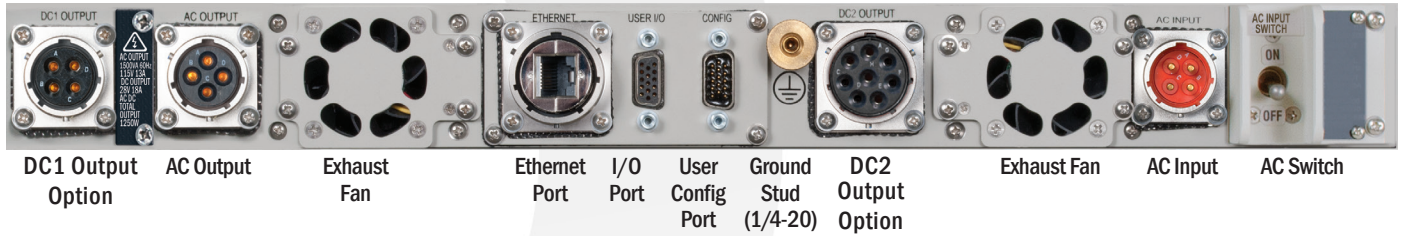

Mechanical Diagram 1U

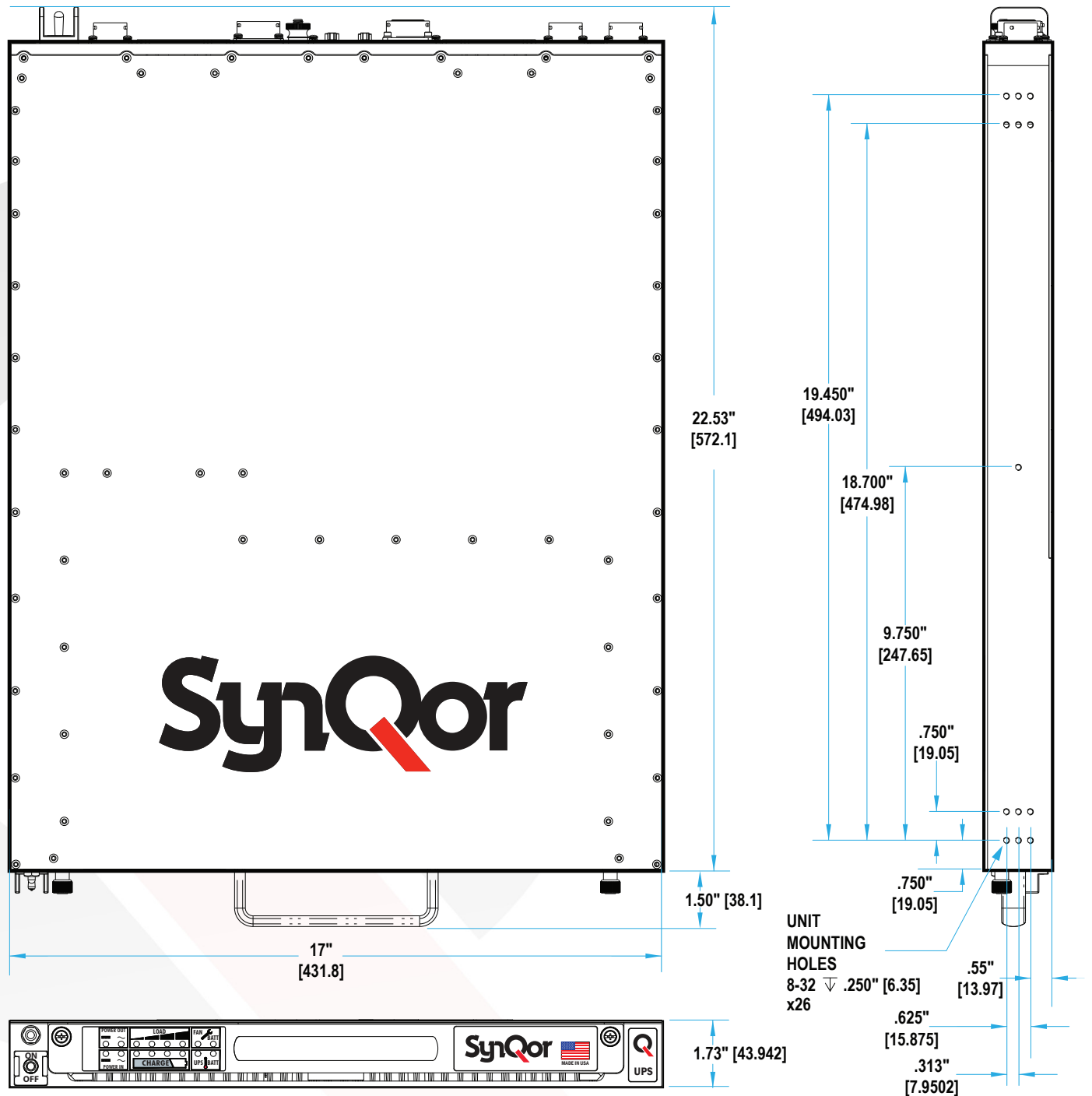

Note:

- 1) ALL DIMENSIONS IN INCHES [mm]
- TOLERANCES: X.XXIN +/- 0.02 [0.5]
- X.XXXIN +/- 0.010 [0.25]

Accessory Options

Replacement Battery Packs		1500 1U
1U: 10 lbs., >10 Min Full Load Run Time		BAT-0200-S-1U-000
1U: 11.8 lbs., >13.5 Min Full Load Run Time		BAT-0400-H-1U-000
1U: 11.8 lbs., >16 Min Full Load Run Time		BAT-0400-M-1U-000
Rail Kits		
Slide Rail Kit ²		SYN-9002
Fixed Bracket Kit ³		SYN-9031
Power Cables (10' long)		
AC Input (Hardwire)		SYN-9113
AC Output (115Vrms) (NEMA 5-20 Receptacle)		SYN-9131
AC Output (Hardwire)		SYN-9130
DC Input (Ring Connectors)		SYN-9151
DC Input (Hardwire)		SYN-9152
DC Input (NATO Connector)		SYN-9154
DC1 Output (Fork Connectors)		SYN-9171
DC1 Output (Hardwire)		SYN-9172
DC2 Output (Hardwire)		SYN-9174
DC2 Output (Fork Connectors)		SYN-9175
AC Output Power Strips (Circular Connector)		
6 NEMA Receptacles with Breaker (1U Rackmount & 3' Cable)		SYN-9232
6 NEMA Receptacles (1U Rackmount & 3' Cable)		SYN-9231
Rackmount Transit Cases		
Transit Case, 3U, Gray, with Casters ³		SYN-9410
Transit Case, 3U, Gray, No Casters ³		SYN-9412
Fan Replacement Kit		
Replaceable Fan Modules		SYN-9450

Notes:

- 1: Other Options also available, check the website or contact power@synqor.com for further information.
- 2: Slide Rail Kit (SYN-9002) is not recommended for transit and ruggedized use.
- 3: Fixed Bracket Kit (SYN-9031) with Transit Case (SYN-9410 or SYN-9412) is required for transit and ruggedized use (qualified to pass MIL-STD-810G Loose Cargo and Transit Drop requirements).



6 NEMA receptacles with Breaker



* Contact factory for additional configuration cables

User Communications (I/O) Cables		
HD DB15M to DB9F (RS232, 10')		SYN-9301
HD DB15M to DB15M (RS232 and Digital I/O, 10')		SYN-9305
Mil-Circular to RJ45 (Ethernet, 10')		SYN-9321
Configuration Cables (AC Output Only)		
HD DB15F to DB15F (2 Units Parallel, 3')		SYN-9311
HD DB15F to DB15F (3 Units Parallel, 6')		SYN-9315
HD DB15F to DB15F (2 Units Series, 3')		SYN-9313
HD DB15F to DB15F (3 Units 3 Phase, 6')		SYN-9317
R-Option Configuration Cables (AC Output Only)*		
HD DB15F to DB15F (2 Units, Expanded Paralleling, 3')		SYN-9341
HD DB15F to DB15F (3 Units 3 Phase, 6')		SYN-9343



Ordering Information

Battery Options				
Model Number	Power	Battery Run-Time @Full Power (80% Power)	Height (W x D x H)	Weight
UPS-1500-S-1U (1 BAT-0200-S Battery Pack)	1250 W 1500 VA	>10 min. (>13 min.)	1U (17.00" x 22.64" x 1.73")	33 lbs.
UPS-1500-H-1U (1 BAT-0400-H Battery Pack)	1250 W 1500 VA	>13.5 min. (>18 min.)	1U (17.00" x 22.64" x 1.73")	34.8 lbs.
UPS-1500-M-1U (1 BAT-0400-M Battery Pack)	1250 W 1500 VA	>16 min. (>22 min.)	1U (17.00" x 22.64" x 1.73")	34.8 lbs.

Base Models	Options							Options	
	AC Input Type	AC Output Voltage	AC Output Neutral Wire	AC Output Set Point Freq	DC Input / DC2 Output	DC1 Output	Additional Options	AC Input Type	AC Output Voltage
UPS-1500-S-1U- UPS-1500-H-1U- UPS-1500-M-1U-	3	1 2	G F R	5 6 4	S D M P R V W Y	00 12 15 24 28 40 50	-E 00	3 3- Phase 115 V (L-L) 45-65Hz	1 115 Vrms 2 230 Vrms
								G Grounded F Floating* R AC Output Electronic Breaker*	5 50 Hz 6 60 Hz 4 400 Hz
								S Not Installed D DC Input M DC2 Out 24 VDC with Droop Share P DC2 Out 24 VDC No Share R DC2 Out 28 VDC with Droop Share V DC2 Out 28 VDC No Share W DC2 Out 50 VDC No Share Y DC2 Out 50 VDC with Droop Share	
								00 None 12 12 V 15 15 V 24 24 V 28 28 V 40 40 V 50 50 V	
								-E Ethernet/SNMP with Configuration Loading 00 No CE Marking	

Not all combinations make valid part numbers, please contact SynQor for availability. See the Product Summary web page for more options.

***Notes:**

Order "F: Floating" option when configuring the AC output for multi-unit combinations of up to 3 units.

Order "R: AC Output Electronic Breaker" option for fault-tolerant, glitch-free parallel systems of up to 32 units with N+M redundancy. The AC output neutral wire will not be connected to the chassis.

Examples:

UPS-1500-S-1U-31G6D28-E00, UPS-1500-S-1U-32G5S00-E00

Contact SynQor for further information and to order:

Phone: 1 (603) 541-4141

Web: www.synqor.com

E-mail: power@synqor.com

Address: 9 Northeastern Blvd., Suite 200, Salem, NH 03079 USA

WARRANTY

SynQor offers a 1 year limited warranty. Complete warranty information is listed on our website or is available upon request from SynQor.

PATENTS

SynQor holds numerous U.S. patents, one or more of which apply to most of its power conversion products. Any that apply to the product(s) listed in this document are identified by markings on the product(s) or on internal components of the product(s) in accordance with U.S. patent laws. SynQor's patents include the following:

7,765,687 7,787,261
 8,149,597 8,644,027