

SynQor®

VPX-3U-AC
VPX-3U-ACUNV-1-CH-001

MILITARY COTS VITA 62 COMPLIANT POWER SUPPLY

85 - 264Vrms Continuous Input Voltage	Input EMI Filtering	6 Outputs	300W Maximum Output Power	84% Typical Efficiency
---	----------------------------	---------------------	-------------------------------------	----------------------------------

Operation: -40 °C to 85 °C (at Card Edge)



VPX Features

▶ Outputs:

VS1:	+12V	@ 25A=	300W
VS2:	+3.3V	@ 20A=	66W
VS3:	+5.0V	@ 30A =	150W
(AUX)	+3.3V_{AUX}	@ 6A =	20W
(AUX)	+12V_{AUX}	@ 1A =	12W
(AUX)	-12V_{AUX}	@ 1A =	12W

- ▶ **Maximum Total Output Power: 300W**
- ▶ **Input EMI Filtering**
- ▶ **Extended Hold-up Time**
- ▶ **Current Sharing on VS1, VS2 and VS3**
- ▶ **Over-current, Over-voltage and Over-temperature Protection**
- ▶ **-40 °C to 85 °C Operating Temperature**
- ▶ **Input Voltage Range: 85 - 264Vrms**
- ▶ **Frequency Range: 47-63Hz / 360-800Hz**
- ▶ **≥0.99 Power Factor**
- ▶ **Optional I²C Function**
 - Supports IPMI/PMBus/VITA 46.11

▶ Compliance:

- **VITA 62**
- **MIL-STD-461F**
 - CE101 ▪ CE102 ▪ CS101 ▪ CS106
 - CS114 ▪ CS115 ▪ CS116
- **VITA 47 / MIL-STD-810G**
 - ESD Protection
 - Shock
 - Vibration
 - Rapid Decompression
 - Corrosion Resistance
 - Fungus Resistance
 - Altitude
 - Humidity

- ▶ **Designed to be compliant with:**
 - **MIL-STD-704 (B-F)**
- ▶ **Height less than 1.6 inch**



Made in USA



Block Diagram for VPX-3U-ACUNV-1-CH-001

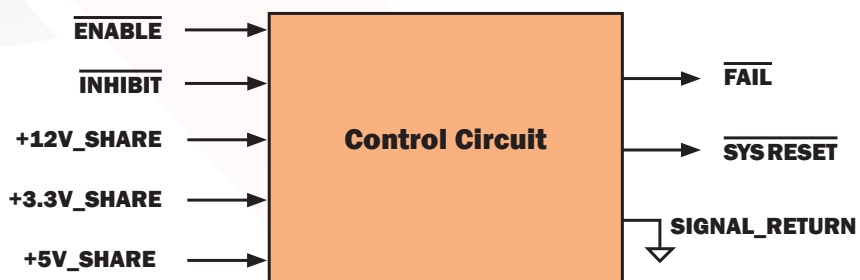
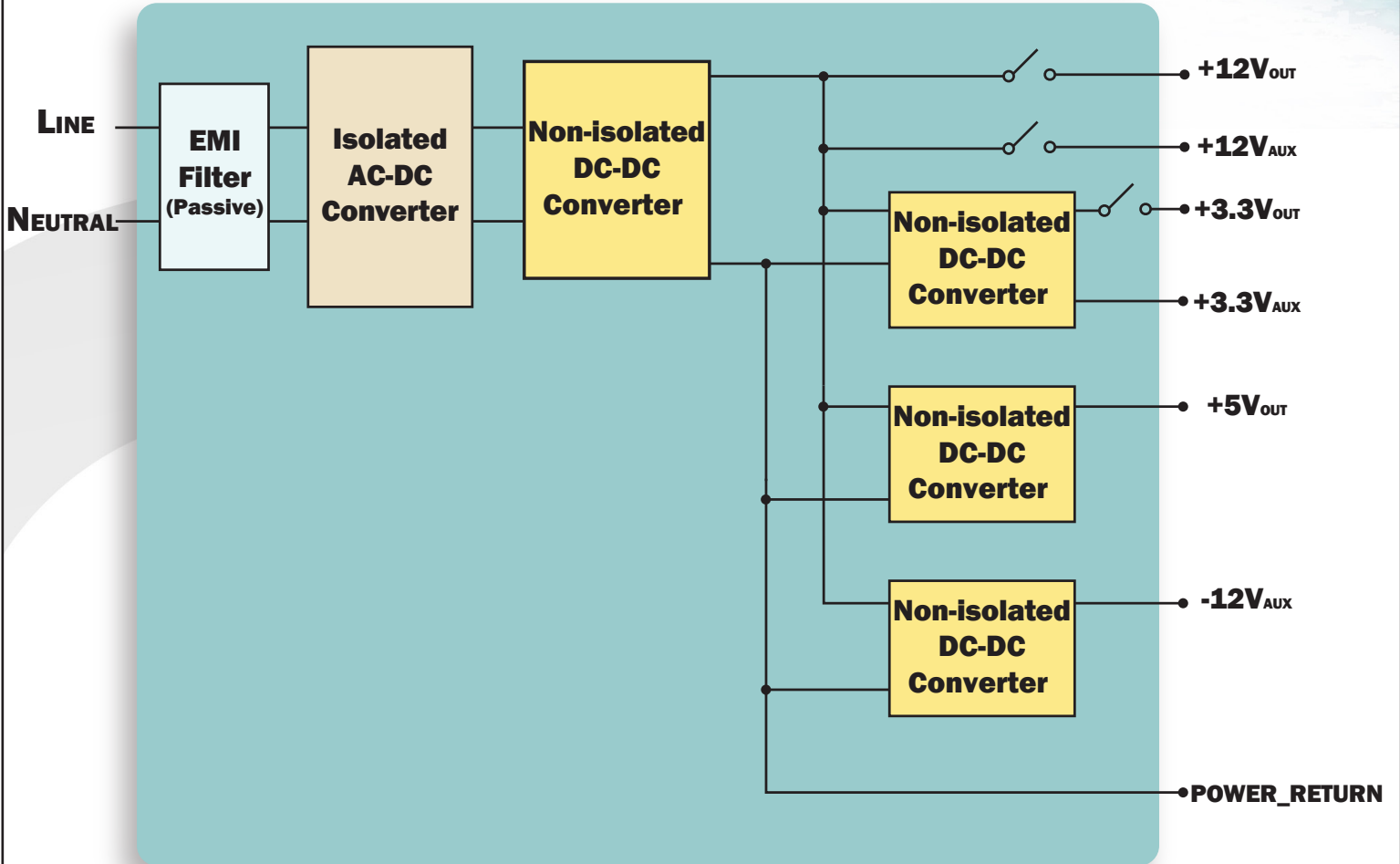

VPX-3U-ACUNV-1-CH-001 Input Characteristics

Parameter	Min.	Typ.	Max.	Units	Notes & Conditions
ABSOLUTE MAXIMUM RATINGS					
Input Voltage			575	Vpk	
Isolation Voltage			1500	Vdc	Input to Output and Input/Output to Case
Operating Temperature	-40		85	°C	Card edge temperature
Storage Temperature	-40		105	°C	
ELECTRICAL CHARACTERISTICS					
Operating Input Voltage Range					
AC Input Continuous	85		264	Vrms	Available output power reduced when <95 Vrms
AC Input 100ms Transient	40		290	Vrms	
Input Under-Voltage Lockout		30		Vrms	> 1s duration
Input Over-Voltage Shutdown		440		Vpk	
Disabled AC Input Current		180	240	mArms	115 Vrms input
Operating Input Frequency	47		800	Hz	
Power Factor of AC Input Current		0.99			50/60Hz, min 200W output
		0.97			400Hz, min 200W output
THD of AC Input Current		3		%	min 200W output
Inrush of AC Input Current					
50/60Hz			10	Apk	
400Hz			20	Apk	
FAIL*/SYSRESET* Signal					
Pull-up resistance	100			Ω	Pull-up to 3.3V on backplane, compliant to VITA 46.0
Sinking current			40	mA	Pull-up to 3.3V on backplane, compliant to VITA 46.0
FEATURE CHARACTERISTICS					
VITA 62 ON/OFF Control					
ENABLE* high-state Voltage	2		3.6	V	ENABLE* regards a no-connect as a high
ENABLE* low-state Voltage			0.8	V	
INHIBIT* high-state Voltage	2		3.6	V	INHIBIT* regards a no-connect as a high
INHIBIT* low-state Voltage			0.8	V	
HOLD-UP CHARACTERISTICS					
Hold-up Time					
300W Output Power, 25°C		90		ms	
250W Output Power, -40°C		90		ms	
RELIABILITY CHARACTERISTICS					
Calculated MTBF (MIL-217) MIL-HDBK-217F		1600		kHrs	Ground Benign, T _a = 25°C
Calculated MTBF (MIL-217) MIL-HDBK-217F		145		kHrs	Ground Mobile, T _a = 25°C

VPX-3U-ACUNV-1-CH-001 Output Characteristics

Parameter	+12V	+5V	+3.3V	+3.3V _{AUX}	+12V _{AUX}	-12V _{AUX}
OUTPUT CHARACTERISTICS						
Output Voltage Set Point See Note 1	12V (+/-1.5%)	5V (+/-1.5%)	3.3V (+/-1.5%)	3.3V (+/-1.5%)	12V (+/-1.5%)	-12V (+/-1.5%)
Total Output Voltage Range See Note 2	12V (+/-4%)	5V (+/-3%)	3.3V (+/-3%)	3.3V (+/-2%)	12V (+/-4%)	-12V (+/-3%)
Output Voltage Ripple (pk-pk) See Note 3	120mV	120mV	40mV	40mV	80mV	120mV
Operating Current Range Maximum Total Output Power = 300W	0-25A	0-30A	0-20A	0-6A	0-1A	0-1A
Over-Voltage Protection	13.0V	6.0V	6.0V	6.0V	14.8V	NA
Current-Limit Inception	30A	40A	40A	40A	2A	1.8A
Maximum Output Capacitance	4mF	10mF	10mF	10mF	1mF	10mF
MAXIMUM TOTAL OUTPUT POWER				300W		

Note 1: 115Vrms, 50% load

Note 2: Over line, load, temperature at steady state

Note 3: Full Load, measured with 1μF capacitor and 10uF tantalum capacitor

Maximum Total Output Power = 300W (Vin > 95 Vrms, T > -20°C)

Maximum Total Output Power derates to 230W at 85 Vrms.

Maximum Total Output Power derates to 250W between -20°C and -40°C.

Temperature specifications are relative to the temperature at the thermal interface, on the flange opposite the wedge locks.



PIN DESCRIPTIONS

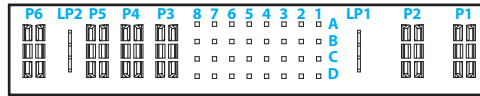

3U PO Connector

PIN	Function	DESCRIPTION
P1	AC_Neutral	Neutral
P2	AC_Line	Line
LP1	CHASSIS	Chassis
A1	STARTUP_SYNC	Startup synchronization
B1	No Connection	
C1	No Connection	
D1	No Connection	
A2	No Connection	
B2	FAIL*	When any of the output is not within specification, FAIL* signal will be driven low to indicate a failure
C2	INHIBIT*	Input control signal as defined in VITA 62, referenced to SIGNAL_RETURN
D2	ENABLE*	Input control signal as defined in VITA 62, referenced to SIGNAL_RETURN
A3	No Connection	
B3	+12V_AUX	+12V auxiliary output voltage, 1A rated
C3	No Connection	
D3	No Connection	
A4	+3.3V_AUX	+3.3V auxiliary output voltage, 6A rated (1.5A per pin)
B4		
C4		
D4		
A5	GA0*	Geographical Address, See Note 1
B5	GA1*	Geographical Address, See Note 1
C5	SM0	Primary I ² C Clock Line, See Note 1
D5	SM1	Primary I ² C Data Line, See Note 1
A6	SM2	Redundant I ² C Clock Line, See Note 1
B6	SM3	Redundant I ² C Data Line, See Note 1
C6	-12V_AUX	-12V auxiliary output voltage, 1A rated
D6	SYSRESET*	System Reset is actively low. It will float when all outputs are within specification
A7	+12V_SHARE	Active current share for +12V_MAIN
B7	+3.3V_SHARE	Active current share for +3.3V_MAIN
C7	+5V_SHARE	Active current share for +5V_MAIN
D7	SIGNAL_RETURN	Ground pin for control signals
A8	+12V_SENSE(+)	Should be connected to +12V_MAIN either remotely or at the connector
B8	+3.3V_SENSE(+)	Should be connected to +3.3V_MAIN either remotely or at the connector
C8	+5V_SENSE(+)	Should be connected to +5V_MAIN either remotely or at the connector
D8	SENSE_RETURN	Should be connected to POWER_RETURN either remotely or at the connector
P3	+5V_MAIN	+5V main output voltage, 30A rated
P4	POWER_RETURN	Common output voltage return pin, 40A rated per pin
P5	POWER_RETURN	
LP2	+3.3V_MAIN	+3.3V main output voltage, 20A rated
P6	+12V_MAIN	+12V main output voltage, 25A rated

Note 1: Refer to SynQor "VPX 3U I²C Operator's Guide" for details regarding the I²C interface.



Mechanical Diagram

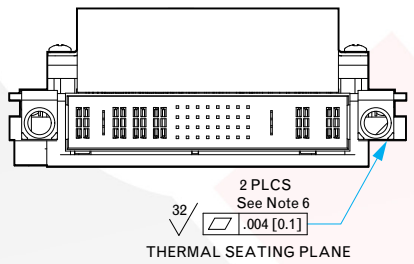
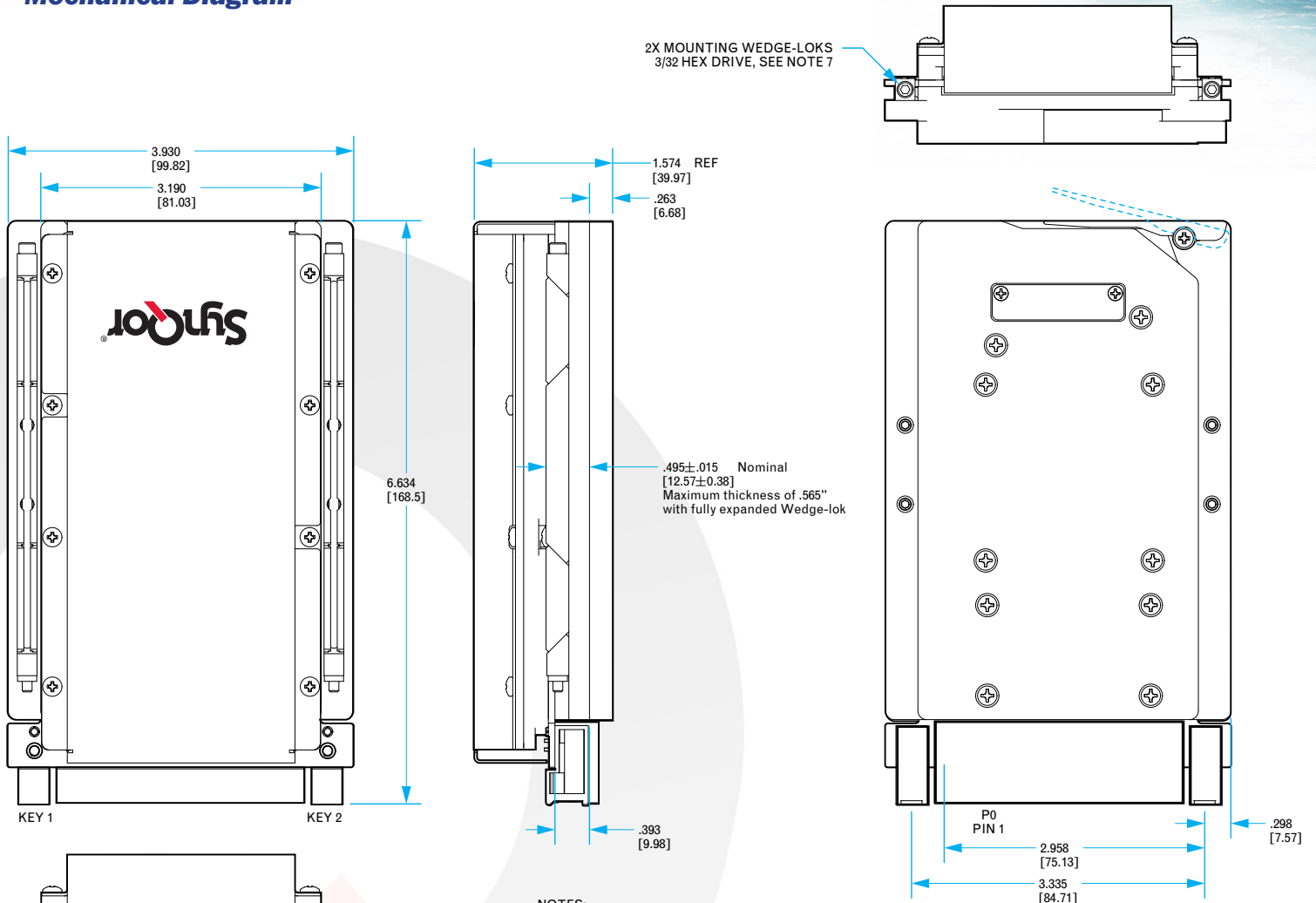

- NOTES:
1. ALL DIMENSIONS IN INCHES
 2. TOLERANCES: X.XX ±0.02in [0.5mm]
X.XXX ±.010in [0.25mm]
 3. CONNECTOR PART NUMBERS:
P0 - TE CONNECTIVITY 6450849-7
P0 - FOXCONN HM811C3-B84F
 4. WEIGHT: SEE TABLE
 5. SEE TABLE FOR KEYWAY POSITION AND ANGLE.
 6. FLATNESS AND SURFACE FINISH REQUIREMENT APPLIES TO BOTH RAILS
 7. RECOMMENDED TORQUE PER EACH MOUNTING WEDGE-LOK: 7 IN-LBS [80 N-CM].

VPX-3U-ACUNV-1-CH-001		
Weight		2.0lbs (.9kg)
Key Position	Alignment Angle	TE Connectivity Part Number
1	270°	1-1469492-7
2	45°	1-1469492-2



Application Notes

Control Features

ENABLE*	Standard VITA 62 control signal. It is used to turn off all of the output voltages when it is high, including +3.3V_AUX. When it is pulled low to SIGNAL_RETURN, +3.3V_AUX will be turned on and the status of the other outputs will be dependent on the state of INHIBIT*. ENABLE* signal regards a no-connect as a high.
INHIBIT*	Standard VITA 62 control signal. It is used to turn off all the output voltages except +3.3V_AUX. When it is pulled low to SIGNAL_RETURN, VS1, VS2, VS3, +12V_AUX and -12V_AUX will be turned off. INHIBIT* signal regards a no-connect as a high. At power-on, if ENABLE* and INHIBIT* are configured to turn all outputs on, +3.3V_AUX will be powered up 100ms prior to when the other outputs are powered up.
FAIL*	FAIL* signal is used to indicate a failure has occurred. It will be pulled low when any of the outputs are outside the voltage specification. FAIL* is an active low open-drain signal. It is expected there will be a pull-up resistor on the backplane to 3.3V. A typical resistor value is 4.7kΩ.
SYSRESET*	SYSRESET* signal is an output generated from the module. It is used to indicate that startup has completed. At power-on, SYSRESET* is pulled low. It will be high impedance when all outputs are within voltage specification. It will be pulled low if any failure has occurred or if the outputs are disabled by the user during operation. SYSRESET* signal is an active low open-drain signal. It is expected there will be a pull-up resistor on the backplane to 3.3V. A typical resistor value is 4.7kΩ.

VITA 62 Control States

ENABLE*	INHIBIT*	+3.3V_AUX	VS1, VS2, VS3, +12V_AUX, -12V_AUX
HIGH	HIGH	OFF	OFF
LOW	HIGH	ON	ON
HIGH	LOW	OFF	OFF
LOW	LOW	ON	OFF

Parallel Operation

+12V_MAIN +5V_MAIN & +3.3V_MAIN	Active current sharing on +12V_MAIN, +5V_MAIN & +3.3V_MAIN are supported with analog sharing schemes. To implement the current sharing function, SHARE pins, ENABLE*, INHIBIT* and SYNC pins should be connected together between all paralleled modules. These SHARE pins are referenced to POWER_RETURN. A clean ground plane is important, and ground drop between each module should be minimized.
+3.3V_AUX +12V_AUX & -12V_AUX	Active current sharing is not supported on auxiliary outputs. However, all rails have OR'ing MOSFETs or OR'ing diodes implemented, so that they can still be operated in parallel. Total output current on these rails should not exceed the current rating of a single module.



VPX-3U-AC
VPX-3U-ACUNV-1-CH-001

VPX Module Qualification (VITA 47 Compliant)

Test Name	Method
Random Vibration	MIL-STD-810, 514.6 - Procedure I, Class V3
Shock	MIL-STD-810, 516.6 - Procedure I, VI, Class OS2
Altitude	MIL-STD-810, 500.5 - Procedure I, II, III
Fungus Resistance	MIL-STD-810, 508.6
Corrosion Resistance	ASTM G85, Annex A4
Humidity	MIL-STD-810, 507.5 - Procedure II
High Temperature	MIL-STD-810, 501.5 - Procedure I, II
Low Temperature	MIL-STD-810, 502.5 - Procedure I, II
Temperature Cycling	MIL-STD-202, 107 - Class C4
ESD	EN61000-4-2, Level 3; 8kV Air Discharge

Internal Mil-COTS Converter and Filter Module Screening

Screening	Process Description	S-Grade	M-Grade
Baseplate Operating Temperature		-55 °C to +100 °C	-55 °C to +100 °C
Storage Temperature		-65 °C to +135 °C	-65 °C to +135 °C
Pre-Cap Inspection	IPC-A-610, Class III	•	•
Temperature Cycling	MIL-STD-883F, Method 1010, Condition B, 10 Cycles		•
Burn-In	100 °C Baseplate	12 Hours	96 Hours
Final Electrical Test	100%	25 °C	-55 °C, +25 °C, +100 °C
Final Visual Inspection	MIL-STD-883F, Method 2009	•	•



VPX-3U-AC
VPX-3U-ACUNV-1-CH-001

Ordering Information / Part Numbering

Series	Package Size (U)	Input Range	Number of Phases	Mil Std Filtering	Output Voltage Combination Code	Packaging Options
VPX	3U	ACUNV	1	CH	001	Y1Y2Y3
VPX	3U	ACUNV:AC Universal Input	1: Single Phase	CH: Clamped Passive Filter Hold-up Capability	001: 001	Y1: Internal Module Screening S - S-Grade (MCOTS) M - M-Grade (MCOTS) Y2: Conformal Coating N - No Conformal Coating C - Conformal Coating Y3: I ² C Function [] - No I ² C 2 - I ² C

Examples: VPX-3U-ACUNV-1-CH-001-SN

Not all combinations make valid part numbers, please contact SynQor for availability.

Contact SynQor for further information and to order:

Phone: 978-849-0600 Fax: 978-849-0602
 E-mail: power@synqor.com Web: www.synqor.com
 Address: 155 Swanson Road, Boxborough, MA 01719 USA

WARRANTY

SynQor offers a one (1) year limited warranty. Complete warranty information is listed on our website or is available upon request from SynQor.

PATENTS

SynQor holds numerous U.S. patents, one or more of which apply to most of its power conversion products. Any that apply to the product(s) listed in this document are identified by markings on the product(s) or on internal components of the product(s) in accordance with U.S. patent laws. SynQor's patents include the following:

7,765,687 7,787,261
 8,149,597 8,644,027