

# SynQor®

**VPX-6U**  
**VPX-6U-DC270P-001**

## MILITARY COTS

# VITA 62 COMPLIANT POWER SUPPLY

<b>155V - 425V</b> Continuous Input Voltage	<b>Input EMI Filtering</b>	<b>5</b> Outputs	<b>730W</b> Maximum Output Power	<b>89%</b> Typical Efficiency
--	----------------------------	---------------------	-------------------------------------	----------------------------------

**Operation: -40 °C to 85 °C (at Card Edge)**



### VPX Features

► **Outputs:**

- VS1: } +12V @ 50A = 600W
- VS2: }
- VS3 (standard): +5.0V @ 30A = 150W
- VS3 (I<sup>2</sup>C option): +5.0V @ 60A = 300W
- (AUX) +3.3V<sub>AUX</sub> @ 40A = 132W
- (AUX) +12V<sub>AUX</sub> @ 1A = 12W
- (AUX) -12V<sub>AUX</sub> @ 1A = 12W

- **Maximum Total Output Power: 730W**
- **Input EMI Filtering**
- **-40 °C to 85 °C Operating Temperature (at Card Edge)**
- **Over-current, over-voltage and over-temperature protection**
- **Current Sharing on +12V, +5.0V & +3.3V<sub>AUX</sub>**
- **Standard VITA 62 Controls**
- **No Electrolytic Capacitors**
- **Optional I<sup>2</sup>C Function**
- **Supports IPMI/PMBus/VITA 46.11**

► **Compliance:**

- **VITA 62**
- **MIL-STD-704**
- **MIL-STD-461**
  - CE102 ▪ CS101 ▪ CS114
  - CS115 ▪ CS116
- **VITA 47 / MIL-STD-810G**
  - ESD Protection
  - Shock
  - Vibration
  - Rapid Decompression
  - Corrosion Resistance
  - Fungus Resistance
  - Altitude
  - Humidity



Made in USA



## Block Diagram for VPX-6U-DC270P-001

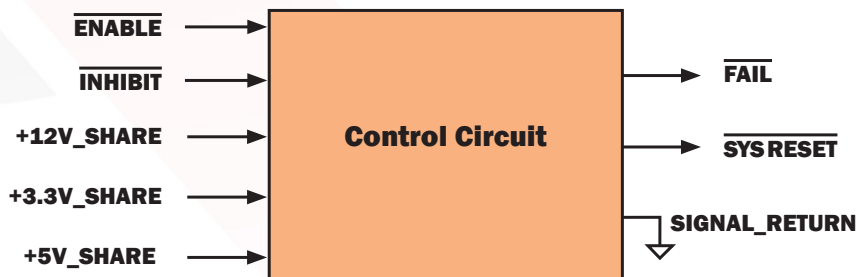
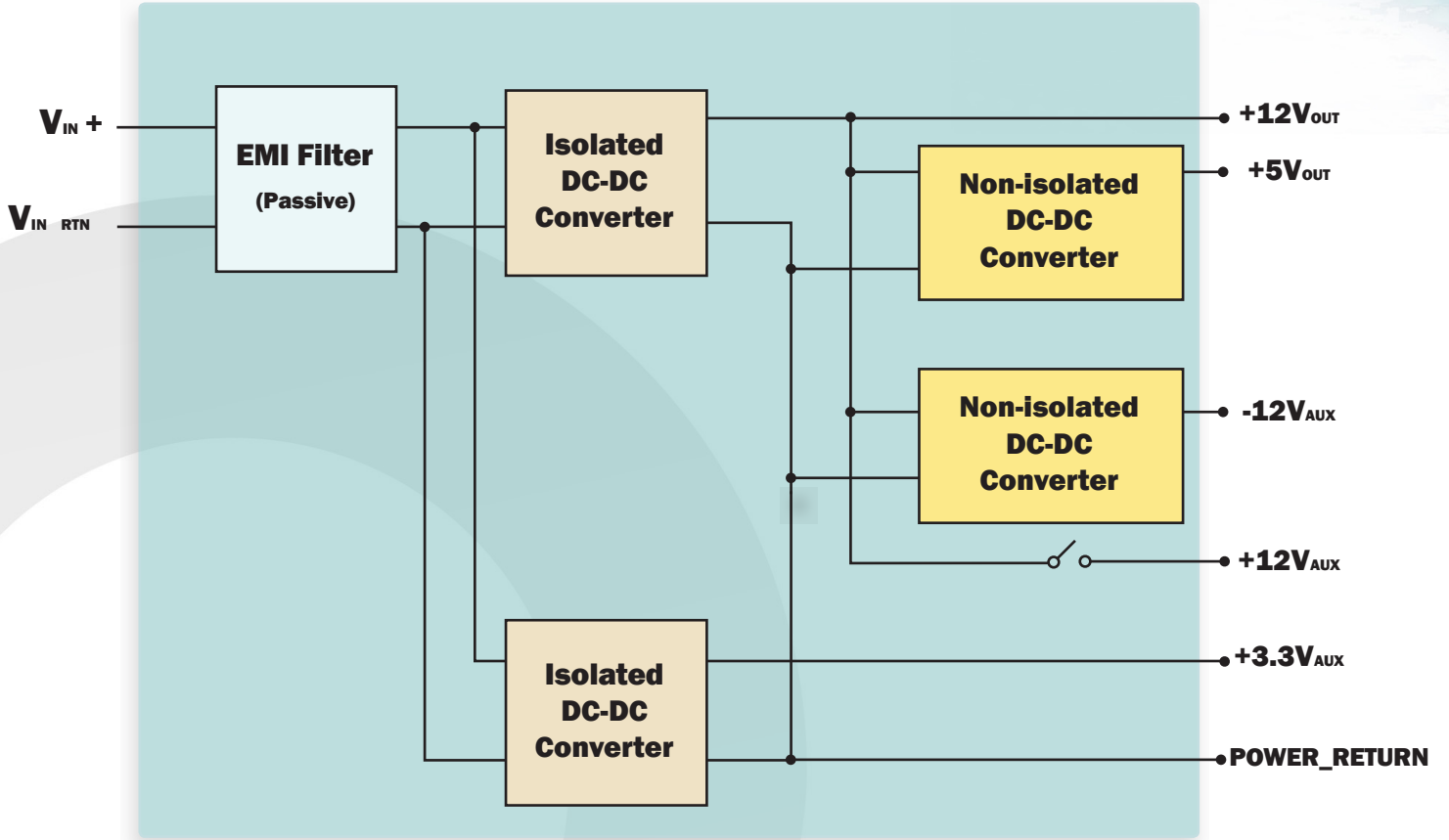



**VPX-6U**  
**VPX-6U-DC270P-001**

## VPX-6U-DC270P-001 Input Characteristics

Parameter	Min.	Typ.	Max.	Units	Notes & Conditions
<b>ABSOLUTE MAXIMUM RATINGS</b>					
<b>Input Voltage</b>					
Non-Operating	-0.5		600	V	Continuous
Operating			425	V	Continuous
Operating Transient Protection			475	V	1s transient, square wave
<b>Isolation Voltage</b>					
Input to Output			2300	Vdc	
Input/Output to Case			2300	Vdc	
<b>Operating Temperature</b>	-40		85	°C	Card edge temperature
<b>Storage Temperature</b>	-55		105	°C	
<b>ELECTRICAL CHARACTERISTICS</b>					
<b>Input Voltage</b>					
Continuous	155	270	425	V	
Transient	155	270	475	V	475V Transient for 1s
<b>Under-Voltage Lockout</b>					
Turn-On Input Voltage Threshold	146	150	154	V	
<b>FAIL*/SYSRESET* Signal</b>					
Pull-up resistance	100			Ω	Pull-up to 3.3V on backplane, compliant to VITA 46.0
Sinking current			40	mA	Pull-up to 3.3V on backplane, compliant to VITA 46.0
<b>FEATURE CHARACTERISTICS</b>					
<b>VITA 62 ON/OFF Control</b>					
ENABLE* high-state Voltage	2		3.6	V	Control signals referenced to SIGNAL_RETURN ENABLE* regards a no-connect as a high
ENABLE* low-state Voltage			0.8	V	
INHIBIT* high-state Voltage	2		3.6	V	INHIBIT* regards a no-connect as a high
INHIBIT* low-state Voltage			0.8	V	
<b>RELIABILITY CHARACTERISTICS</b>					
Calculated MTBF (MIL-217) MIL-HDBK-217F		1600		kHrs	Ground Benign, T <sub>A</sub> = 25°C
Calculated MTBF (MIL-217) MIL-HDBK-217F		160		kHrs	Ground Mobile, T <sub>A</sub> = 25°C

## VPX-6U-DC270P-001 Output Characteristics

Parameter	+12V	+5V	+3.3V <sub>AUX</sub>	+12V <sub>AUX</sub>	-12V <sub>AUX</sub>
<b>OUTPUT CHARACTERISTICS</b>					
<b>Output Voltage Set Point</b> See Note 1	<b>12V</b> (+/-1.5%)	<b>5V</b> (+/-1.5%)	<b>3.3V</b> (+/-1.5%)	<b>12V</b> (+/-1.5%)	<b>-12V</b> (+/-1.5%)
<b>Total Output Voltage Range</b> See Note 2	<b>12V</b> (+/-4%)	<b>5V</b> (+/-3%)	<b>3.3V</b> (+/-3%)	<b>12V</b> (+/-4%)	<b>-12V</b> (+/-3%)
<b>Output Voltage Ripple (pk-pk)</b> See Note 3	<b>80mV</b>	<b>50mV</b>	<b>80mV</b>	<b>80mV</b>	<b>50mV</b>
<b>Operating Current Range</b> Maximum Total Output Power = 730W	<b>0-50A</b>	<b>30A (std)</b> <b>60A (I<sup>2</sup>C)</b>	<b>0-40A</b>	<b>0-1A</b>	<b>0-1A</b>
<b>Over-Voltage Protection</b>	<b>15.0V</b>	<b>6.0V</b>	<b>4.1V</b>	<b>15V</b>	<b>NA</b>
<b>Current-Limit Inception</b>	<b>62.5A</b>	<b>40A/120A</b>	<b>75A</b>	<b>2A</b>	<b>1.8A</b>
<b>Maximum Output Capacitance</b>	<b>10mF</b>	<b>10mF</b>	<b>25mF</b>	<b>1mF</b>	<b>10mF</b>
<b>MAXIMUM TOTAL OUTPUT POWER</b>	<b>730W</b>				

**Note 1:** 270V<sub>in</sub>, 50% load

**Note 2:** Over line, load, temperature

**Note 3:** Full Load, measured with 1μF capacitor and 10uF tantalum capacitor

**Maximum Total Output Power = 730W (Full Temperature Range)**

LED Appearance	Description
Red	Input applied, all outputs are disabled
Amber	+3.3V_AUX is enabled, all other outputs are disabled
Green	All outputs are enabled and there is no fault condition
Blinking Red	Unit has a fault condition
Off	No input applied or LED disabled by user



### PIN DESCRIPTIONS

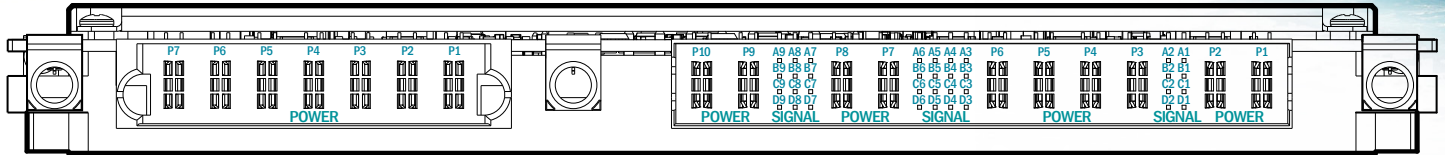

6U P0 Connector

6U P1 Connector

PIN	Function	DESCRIPTION
P7	+DC_IN	Vin+
P6	+DC_IN	Vin+
P5	-DC_IN	Vin-
P4	-DC_IN	Vin-
P3	No Connection	
P2	No Connection	
P1	CHASSIS	Chassis

PIN	Function	DESCRIPTION
P10	+12V_MAIN	+12V main output voltage, 50A rated
P9	+12V_MAIN	
A9	+12V_SENSE(+)	Should be connected to +12V_MAIN either remotely or at the connector
B9	+12V_SENSE(+)	
C9	+5V_SENSE(+)	Should be connected to +5V_MAIN either remotely or at the connector
D9	LED_DISABLE	Internally pulled up to 3.3V, connect to SIGNAL_RETURN to disable LED
A8	+12V_SENSE(-)	Should be connected to POWER_RETURN either remotely or at the connector
B8	+12V_SENSE(-)	
C8	+5V_SENSE(-)	Should be connected to POWER_RETURN (available on I <sup>2</sup> C option only)
D8	+12V_SYNC	Startup synchronization for +12V_MAIN
A7	+12V_SHARE	Active current share for +12V_MAIN
B7	+5V_SHARE	Active current share for +5V_MAIN
C7	+3.3V_SHARE	Active current share for +3.3V_AUX
D7	SIGNAL_RETURN	Ground pin for control signals
P8	POWER_RETURN	Common output voltage return pin, 40A rated per pin
P7	POWER_RETURN	
A6	SM2	Redundant I <sup>2</sup> C Clock Line, See Note 1
B6	SM3	Redundant I <sup>2</sup> C Data Line, See Note 1
C6	-12V_AUX	-12V auxiliary output voltage, 1A rated
D6	SYSRESET*	System Reset is actively low. It will float when all outputs are within specification
A5	GAP*	Geographical Address, See Note 1
B5	GA4*	Geographical Address, See Note 1
C5	SM0	Primary I <sup>2</sup> C Clock Line, See Note 1
D5	SM1	Primary I <sup>2</sup> C Data Line, See Note 1
A4	GA3*	Geographical Address, See Note 1
B4	GA2*	Geographical Address, See Note 1
C4	GA1*	Geographical Address, See Note 1
D4	GA0*	Geographical Address, See Note 1
A3	+5V_SYNC	Startup synchronization for +5V_MAIN
B3	+12V_AUX	+12V auxiliary output voltage, 1A rated
C3	No Connection	
D3	No Connection	
P6	+5V_MAIN	+5V main output voltage, 30A rated for standard option and 60A for I <sup>2</sup> C option
P5	+5V_MAIN	
P4	POWER_RETURN	Common output voltage return pin, 40A rated per pin
P3	POWER_RETURN	
A2	No Connection	
B2	FAIL*	When any of the output is not within specification, FAIL* signal will be driven low
C2	INHIBIT*	Input control signal as defined in VITA 62, referenced to SIGNAL_RETURN
D2	ENABLE*	Input control signal as defined in VITA 62, referenced to SIGNAL_RETURN
A1	+3.3V_SYNC	Startup synchronization for +3.3V_AUX
B1	No Connection	
C1	No Connection	
D1	No Connection	
P2	+3.3V_AUX	+3.3V auxiliary output voltage, 40A rated
P1	POWER_RETURN	Common output voltage return pin, 40A rated per pin

Note 1: Refer to SynQor "VPX 6U I<sup>2</sup>C Operator's Guide" for details regarding the I<sup>2</sup>C interface.



**VPX-6U**  
**VPX-6U-DC270P-001**

**Mechanical Diagram**

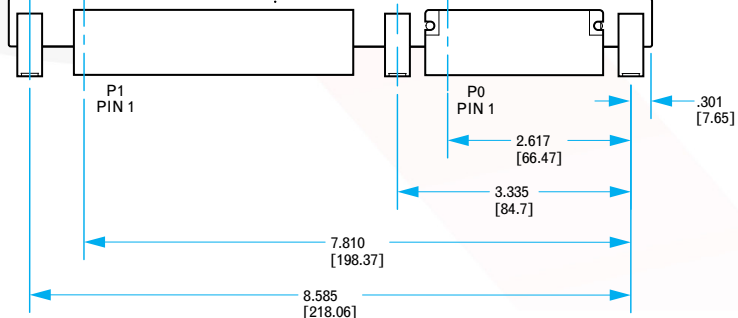
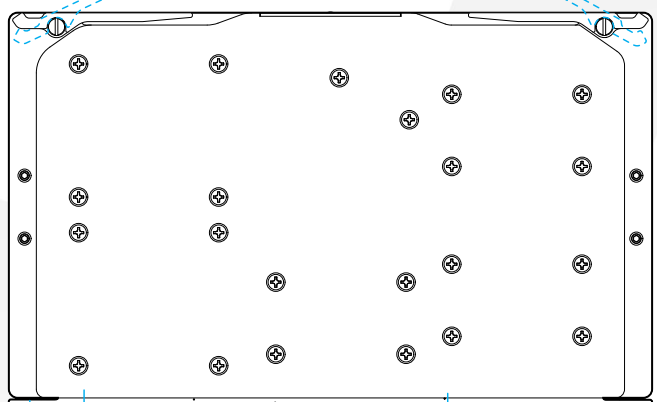
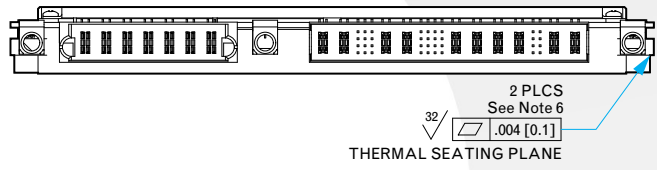
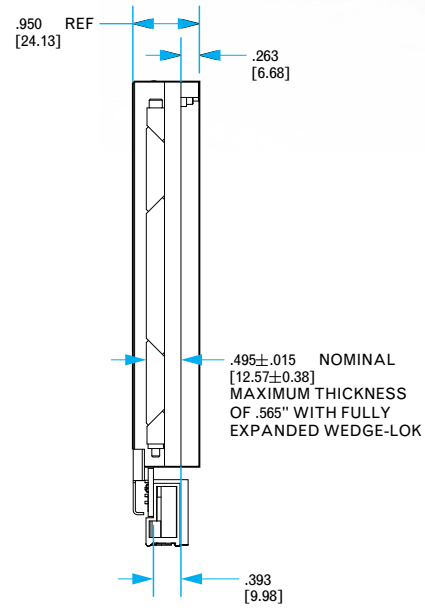
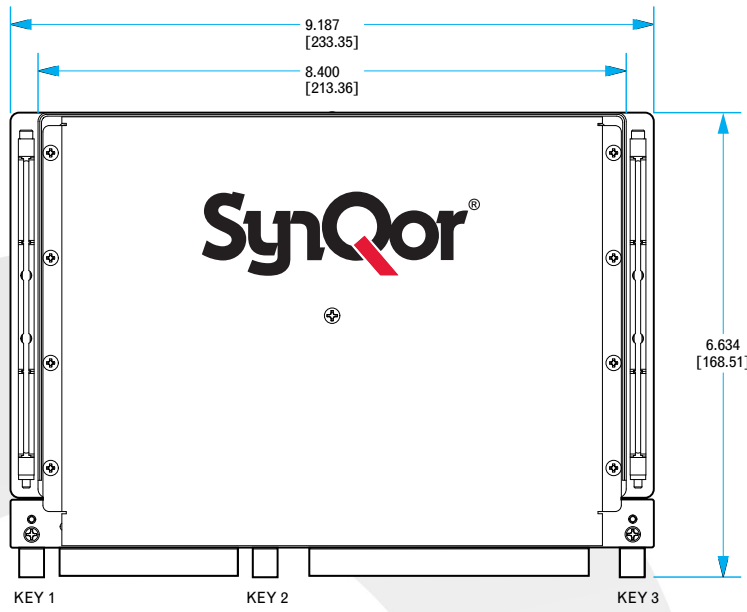

- NOTES:**
1. ALL DIMENSIONS IN INCHES
  2. TOLERANCES: X.XX ±0.02in [0,5mm]  
X.XXX ±.010in [0,25mm]
  3. CONNECTOR PART NUMBERS:  
P0 - TE CONNECTIVITY 6450843-6  
P0 - FOXCONN HM811J3-B84F  
P1 - TE CONNECTIVITY 6450849-6  
P1 - FOXCONN HM811L3-B84F
  4. WEIGHT: SEE TABLE
  5. SEE TABLE FOR KEYWAY POSITION AND ANGLE.
  6. FLATNESS AND SURFACE FINISH REQUIREMENT APPLIES TO BOTH RAILS
  7. RECOMMENDED TORQUE PER EACH MOUNTING WEDGE-LOK: 7 IN-LBS [80 N-CM].

VPX-6U-DC270P-001		
Weight	3.8lbs (1.7kg)	
Key Position	Alignment Angle	TE Connectivity Part Number
1	315°	1-1469492-8
2	0°	1-1469492-1
3	0°	1-1469492-1



## Application Notes

### Control Features

<b>ENABLE*</b>	Standard VITA 62 control signal. It is used to turn off all of the output voltages when it is high, including +3.3V_AUX. When it is pulled low to SIGNAL_RETURN, +3.3V_AUX will be turned on and the status of the other outputs will be dependent on the state of INHIBIT*. ENABLE* signal regards a no-connect as a high.
<b>INHIBIT*</b>	Standard VITA 62 control signal. It is used to turn off all the output voltages except +3.3V_AUX. When it is pulled low to SIGNAL_RETURN, VS1, VS2, VS3, +12V_AUX and -12V_AUX will be turned off. INHIBIT* signal regards a no-connect as a high. At power-on, if ENABLE* and INHIBIT* are configured to turn all outputs on, +3.3V_AUX will be powered up 100ms prior to when the other outputs are powered up.
<b>FAIL*</b>	FAIL* signal is used to indicate a failure has occurred. It will be pulled low when any of the outputs are outside the voltage specification. FAIL* is an active low open-drain signal. It is expected there will be a pull-up resistor on the backplane to 3.3V. A typical resistor value is 4.7kΩ.
<b>SYSRESET*</b>	SYSRESET* signal is an output generated from the module. It is used to indicate that startup has completed. At power-on, SYSRESET* is pulled low. It will be high impedance when all outputs are within voltage specification. It will be pulled low if any failure has occurred or if the outputs are disabled by the user during operation. SYSRESET* signal is an active low open-drain signal. It is expected there will be a pull-up resistor on the backplane to 3.3V. A typical resistor value is 4.7kΩ.

### VITA 62 Control States

ENABLE*	INHIBIT*	+3.3V_AUX	VS1, VS2, VS3, +12V_AUX, -12V_AUX
HIGH	HIGH	OFF	OFF
LOW	HIGH	ON	ON
HIGH	LOW	OFF	OFF
LOW	LOW	ON	OFF

### Parallel Operation

<b>+12V_MAIN +5V_MAIN &amp; +3.3V_AUX</b>	Active current sharing on +12V_MAIN, +5V_MAIN & +3.3V_AUX are supported with analog sharing schemes. To implement the current sharing function, SHARE pins, ENABLE*, INHIBIT* and SYNC pins should be connected together between all paralleled modules. These SHARE pins are referenced to POWER_RETURN. A clean ground plane is important, and ground drop between each module should be minimized.
<b>+12V_AUX &amp; -12V_AUX</b>	Active current sharing is not supported on +12V_AUX and -12V_AUX. However, both rails have ORing MOSFETs or ORing diodes implemented, so that they can still be operated in parallel. Total output current on these rails should not exceed the current rating of a single module.



## VPX Module Qualification (VITA 47 Compliant)

Test Name	Method
Random Vibration	MIL-STD-810, 514.6 - Procedure I, Class V3
Shock	MIL-STD-810, 516.6 - Procedure I, VI, Class OS2
Altitude	MIL-STD-810, 500.5 - Procedure I, II, III
Fungus Resistance	MIL-STD-810, 508.6
Corrosion Resistance	ASTM G85, Annex A4
Humidity	MIL-STD-810, 507.5 - Procedure II
High Temperature	MIL-STD-810, 501.5 - Procedure I, II
Low Temperature	MIL-STD-810, 502.5 - Procedure I, II
Temperature Cycling	MIL-STD-202, 107 - Class C4
ESD	EN61000-4-2, Level 4; 15kV Air Discharge

### Internal Mil-COTS Converter and Filter Module Screening

Screening	Process Description	S-Grade	M-Grade
Baseplate Operating Temperature		-55 °C to +100 °C	-55 °C to +100 °C
Storage Temperature		-65 °C to +135 °C	-65 °C to +135 °C
Pre-Cap Inspection	IPC-A-610, Class III	•	•
Temperature Cycling	MIL-STD-883F, Method 1010, Condition B, 10 Cycles		•
Burn-In	100 °C Baseplate	12 Hours	96 Hours
Final Electrical Test	100%	25 °C	-55 °C, +25 °C, +100 °C
Final Visual Inspection	MIL-STD-883F, Method 2009	•	•



## Ordering Information / Part Numbering

Series	Package Size (U)	Input Range	Mil Std Filtering	Output Voltage Combination Code	Packaging Options
VPX	6U	DC270	P	001	Y1Y2Y3
VPX	6U	DC270: 270V	P: Passive Filter	001: 001	<b>Y1:</b> Internal Module Screening S - Standard (MCOTS) M - Military (MCOTS) <b>Y2:</b> Conformal Coating N - No Conformal Coating C - Conformal Coating <b>Y3:</b> I <sup>2</sup> C Function [ ] - No I <sup>2</sup> C 2 - I <sup>2</sup> C

### Examples:

VPX-6U-DC270P-001-SN

VPX-6U-DC270P-001-MC2

Not all combinations make valid part numbers, please contact SynQor for availability.

### Contact SynQor for further information and to order:

**Phone:** 978-849-0600  
**Toll Free:** 888-567-9596  
**Fax:** 978-849-0602  
**E-mail:** [power@synqor.com](mailto:power@synqor.com)  
**Web:** [www.synqor.com](http://www.synqor.com)  
**Address:** 155 Swanson Road  
 Boxborough, MA 01719  
 USA

### PATENTS

SynQor holds numerous U.S. patents, one or more of which apply to most of its power conversion products. Any that apply to the product(s) listed in this document are identified by markings on the product(s) or on internal components of the product(s) in accordance with U.S. patent laws. SynQor's patents include the following:

7,050,309 7,765,687 7,787,261  
8,149,597 8,644,027

### WARRANTY

SynQor offers a one (1) year limited warranty. Complete warranty information is listed on our website or is available upon request from SynQor.