

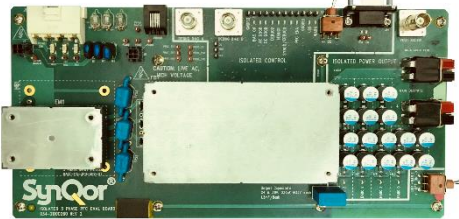

Advancing The Power Curve®



EVAL-KIT-1000033-01

Evaluation KIT for Isolated 3-Phase PFC Converters

Summary

SynQor has developed EVAL-1000033-01, an evaluation board to facilitate testing of our Isolated 3-Phase PFC converters and our AC Line Filters specifically designed to interface with our Isolated 3-Phase PFC converters.

Introduction

This application note is a guide to the features, schematic, component placement, and BOM for this evaluation board. The applicable modules are MACF-115-3PH-UNV-QG (3-Phase AC Line Filter) and the MPFIC-115-3PH-28R-FT (3-Phase PFC converters).

Contents

- Section 1 – Converter Description
- Section 2 – Evaluation Board Block Diagram
- Section 3 – Schematic
- Section 4 – Component Placement
- Section 5 – Basic Operating Instructions

This evaluation board and schematic are intended for demonstration purposes only and no guarantees are made for standards compliance.

Section 1 – Converter Description

The MPFICQor Military Isolated PFC Module is a high power, high efficiency AC-DC converter. It operates from a 3-Phase AC input (115 Vrms L-N / 200 Vrms L-L) and generates an isolated DC output. Used in conjunction with a holdup capacitor, and SynQor's QG series MCOTS AC line filter, the MPFICQor will draw a nearly perfect sinusoidal current that is in phase with the 3-Phase AC input voltage ($PF > 0.99$).

The 3-Phase PFC converter has two stages. The input stage takes 3-Phase AC (115 Vrms L-N / 200 Vrms L-L) and shapes and balances the three AC input currents. The PFC module works with any input phase rotation. The 3-Phase PFC will startup and operate under any valid load condition. The second stage utilizes a Bus Converter to generate an isolated regulated DC output. A boost converter between the active PFC and the Bus converter's input supports the output during input line sags and brownout conditions.

The term "line-to-neutral (L-N) voltage" is used in this document even though this converter does not utilize a neutral wire. If a neutral wire is present in the application, it should not be connected to the PFC.

Thermal Considerations: When testing EMI Filters and converters on an evaluation board, ensure adequate cooling. Apply cooling air with a fan blowing across the EMI Filter and the converter or across the heatsinks attached to the EMI Filter and converter. Monitor the EMI Filter and converter temperatures to ensure they don't exceed the maximum rated per the data sheets' specifications.

Shock Warning: There are areas of this evaluation board that have exposed access to hazardous voltage levels. Exercise caution to avoid contact with those voltages. Also note that the evaluation board may retain high voltage temporarily after input power has been removed. Exercise caution when handling.

Isolation Warning: Circuitry on this evaluation board is both isolated and non-isolated with respect to the AC line inputs on J16. This requires great care in making connections and taking measurements. As such, take great care before taking any measurement with equipment that may make a connection to earth ground. Use isolated differential probes or clamp on style current probes to avoid these issues. The circuits that are isolated from the AC line inputs can use a regular grounded scope probe to take measurements.

In most applications, the output of the 3-Phase PFC will be followed by an isolated DC-DC converter. The serial port J14 and enable switch S1 are isolated.

Section 2 – Evaluation Board Block Diagram

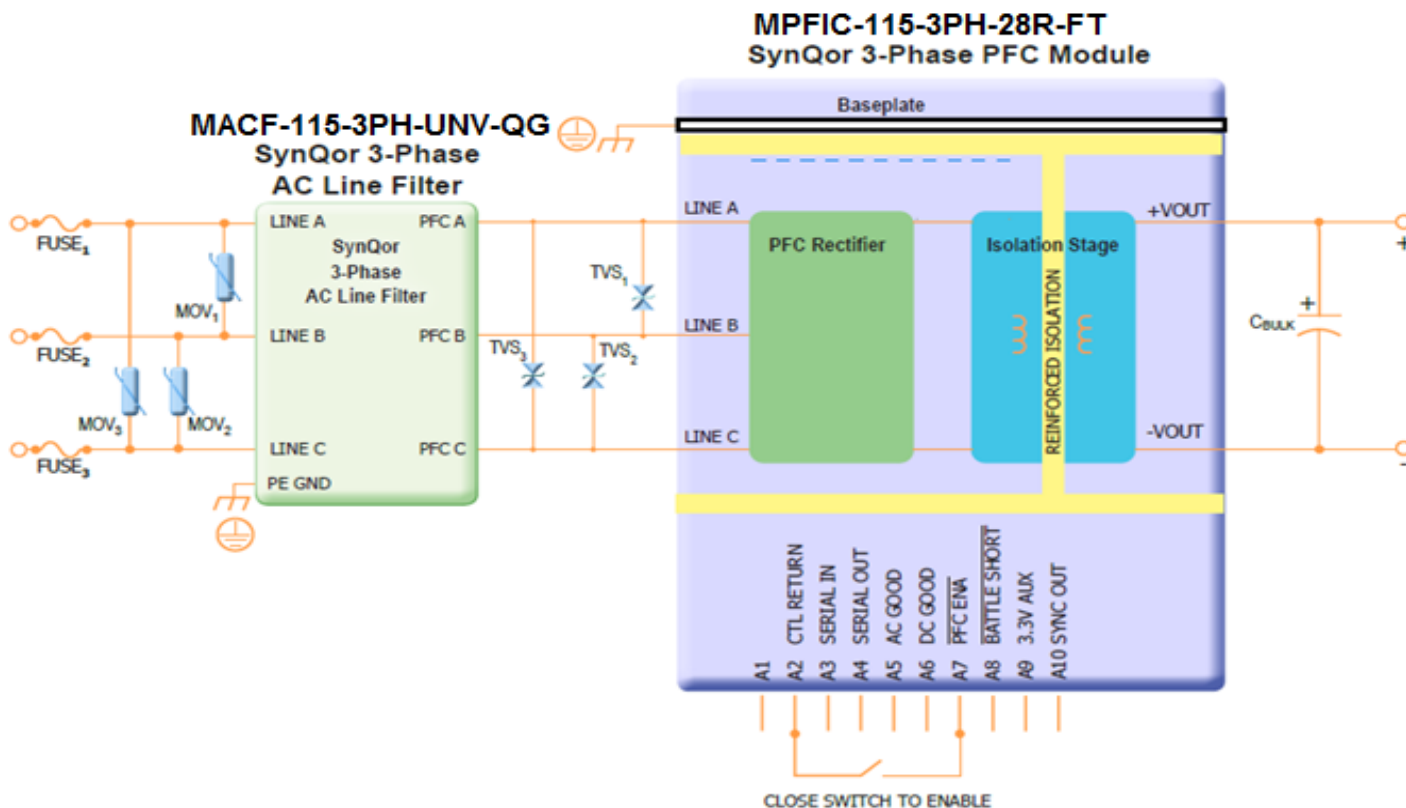

Suggested Parts:

MOV 1-3 : 300 Vrms, 60 J ; EPCOS S10K300E2
 TVS 1-3 : 430 Vpk, 20 J; Littelfuse AK3-430C or Bourns PTVS-430C-TH
 Fuse 1-3 : 250 Vrms, 10 A; Littelfuse R451 010. MR

Notes:

Note 1: Additional Hold-Up capacitance across CBulk may be required for normal operation through interruptions in input power.

Note 2: DC-DC Converters can be used as a load across Vout, An Input Stability calculation will need to be performed to ensure proper damping of the system. Typically, CBulk will be a sufficient capacitance and ESR for damping the network across Vout. An additional capacitor or capacitor with a resistor in series may be required in parallel with CBulk to achieve the final values to ensure proper damping of the system. SynQor’s application notes “Guidelines for Testing SynQor DC-DC Converters” and “Input System Instability” explain in detail how to configure a test when the load connected to the DC output of this application board is comprised of one or more DC to DC converters.

Section 3 – Schematic

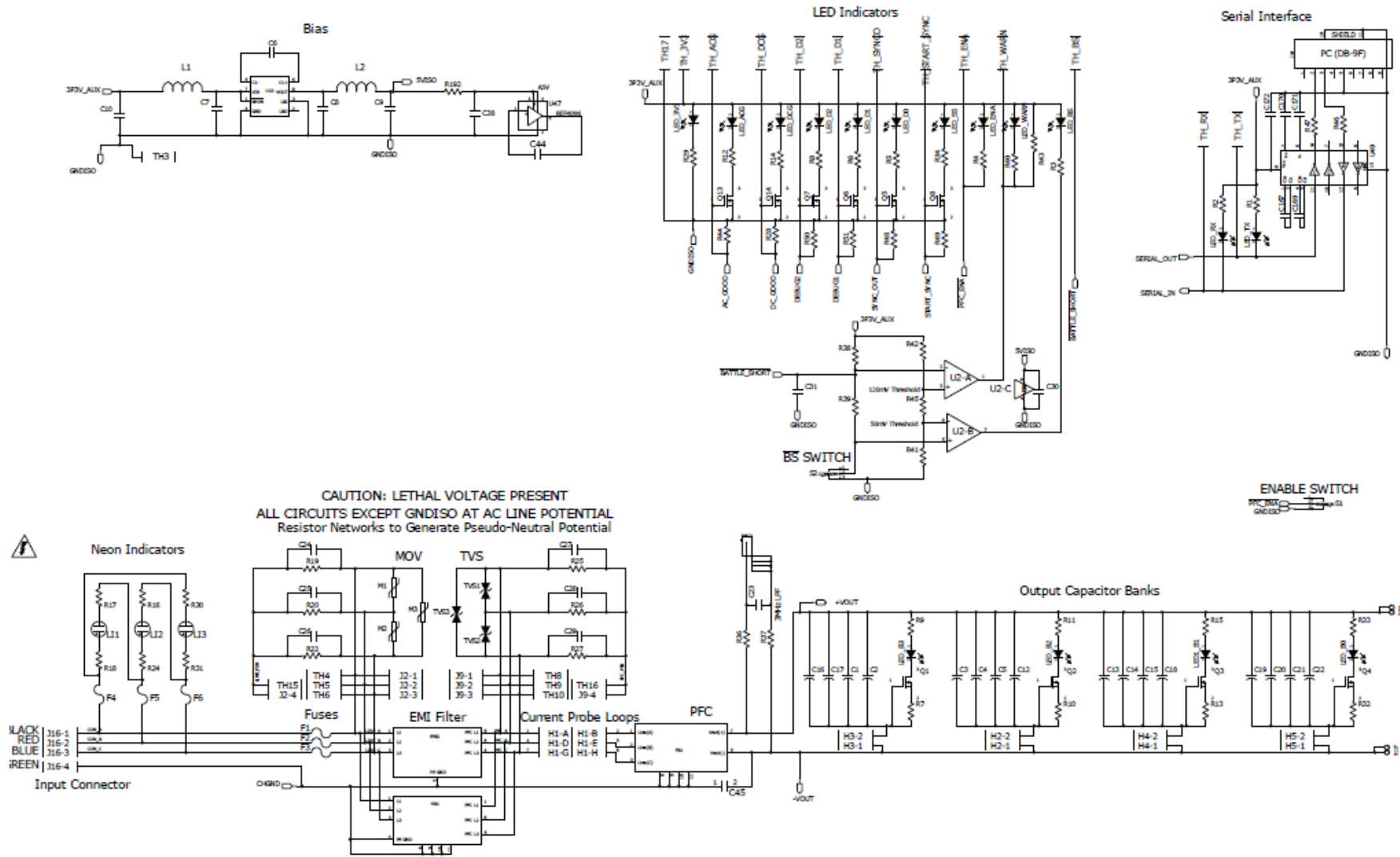

Section 4 – Component Placement

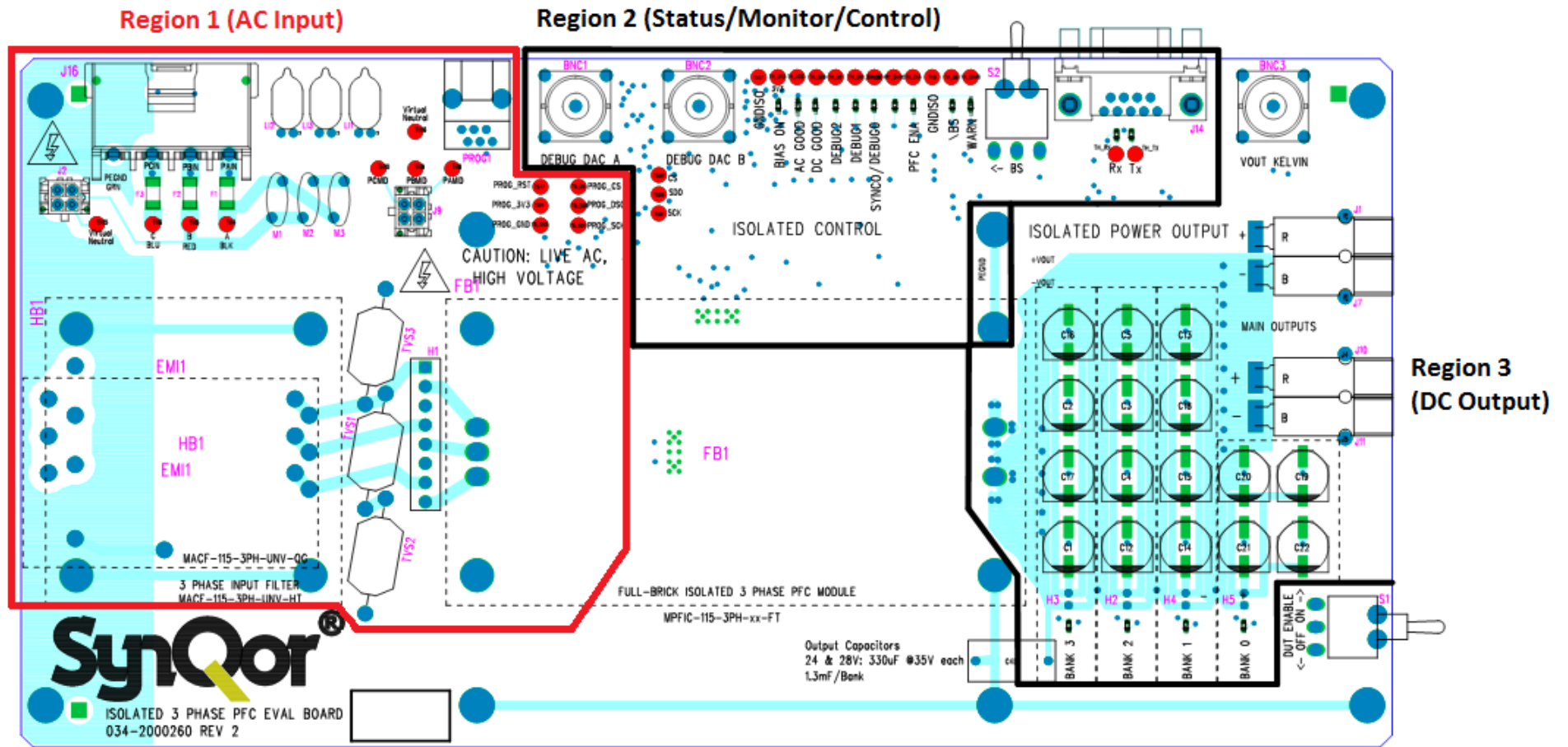

Section 4 – Component Placement

Region 1 (AC Input)

CAUTION: All the signals in Region 1 are LIVE to the AC Input. All the testpoints here are red – indicating that differential scope probes must be used in monitoring these signals.

Input power is applied through connector J16, see Table 1. Phases A, B, and C are labeled. There is no neutral connection, and phase rotation (A, B, C) does not matter to the device. Tables 2 and 3 list the fuses, TVS and MOV devices, along with suggested part numbers.

Table 1: Input Power Connector J16

Connector Terminal #	Signal Name	Part Number
J16-1	AC Line A Input	Hirose Electric Company, DF22-4S-7.92C (28)
J16-2	AC Line B Input	
J16-3	AC Line C Input	
J16-4	Earth Ground	

Table 2: Fuses

RefDes	Value	Package	Part Number
F1, F2, F3	10 A	2410	Littlefuse, 0451 010.MRL
F4, F5, F6	0.25 A	2410	Littlefuse, 0451 .250MRL

Table 3: TVS and MOV Devices:

RefDes	Value	Package	Part Number
M1, M2, M3	300V AC	Radial, 10mm disc	Metal Oxide Varistor, Epcos, S10K300E2
TVS1, TVS2, TVS3	430V	Through Hole	High Energy Bidirectional TVS, Littelfuse, AK3-430C

Neon Lamp Indicators LI1 – LI3 (Top left hand side of board)

- LI1: AC voltage present from Line A to Line B when illuminated.
- LI2: AC voltage present from Line B to Line C when illuminated.
- LI3: AC voltage present from Line C to Line A when illuminated.

Reference Designator	Test Point Signal Names	Test Point Color
TH4	LINE_A	Red
TH5	LINE_B	Red
TH6	LINE_C	Red
TH15/TH16	VIRTUAL NEUTRAL	Red
TH8	PAMID	Red
TH9	PBMID	Red
TH10	PCMID	Red

Section 4 – Component Placement

AC Input - Scope Probing Options.

- AC Line-Line Input voltages can be monitored with differential scope probes attached between any of the test points labeled A (Blk), B (Red) and C (Blu). A resistive averaged Virtual Neutral testpoint is provided for making L-N measurements.
- AC Input voltages at the PFC module can be monitored with differential scope probes attached between any of the test points labeled PAMID, PB MID and PC MID. A separate Virtual Neutral testpoint is also provided at the PFC input
- AC Input Phase currents can be monitored by installing current loops in to Header H1 and using an isolated current probe to measure each of the currents.

The evaluation board includes protective MOV devices across all three input lines. These are in place to absorb energy from potential transients that may be present on the AC line. The MOV devices are EPCOS S10K300E2.

Line to Line transient voltage suppressors (TVS) are included after each filter to clamp the peak voltage seen by the PFC module, when stimulated by an input transient. The TVS devices are Littelfuse AK3-430C or Bourns PTVS-430C-TH

Region 2 (Status/Monitor/Control)

All signals in this region are reference to GND ISO – which is fully isolated from both the AC Input and the DC Output regions/signals. The testpoints here are black – indicating that standard scope probes may be utilized.

There are several different test points on the (Status/Monitor/Control) section of the evaluation board that can be visually monitored via the LEDs or probed on the adjacent test points as described below.

LED LABEL	Test Point Signal	Meaning
	GNDISO	Reference level for control signals
BIAS ON	3P3V_AUX	DUTs 3v3 Aux Bias Output
AC GOOD	AC_GOOD	DUT's AC_GOOD Output Pin
DC GOOD	DC_GOOD	DUT's DC_GOOD Output Pin
DEBUG2	DEBUG2	NA
DEBUG1	DEBUG1	NA
DEBUG0/SYNCO	SYNC_OUT	DUT's SYNC OUT Output Pin
(blank)	START_SYNC	DUT's START_SYNC I/O Pin
PFC ENA	PFC_ENA	DUT's PFC_ENA Input Pin
	GNDISO	Reference level for control signals
\BS	DEBUG 2	DUT's /BS IO Pin
WARN	TH_WARN	Lit/High when DUT is warning shutdown
RX		Blinks when characters are being received
TX		Blinks when characters are being transmitted

Control Switches

Enable On/Off Switch

Setting S1 switch to the ON position enables the 3-Phase PFC converter; setting S1 switch to the OFF position disables the 3-Phase PFC converter.

Section 4 – Component Placement

Battle Short On/Off Switch

Settling S2 switch to the ON position disables the OTP and AC Line Imbalance protection circuitry of the 3-Phase PFC converter as described in its datasheet.

Serial Interface Communications

To communicate with the adaptor board kit, a DB9 Male to RS232 cable can be used for a direct connection to an RS-232 port.

The serial port uses 9600 baud, 8 data bits, no parity, and one stop bit. Commands can be sent, and output viewed, with any standard terminal emulator.

Manufacturer	Part Number	Description
Assmann WSW Components	AE1324-ND	Cable DB9/25Male

Please refer to application note [SynQor 3-Phase PFC Terminal Commands](#) for information regarding the communications standards and parameters available for monitoring.

Region 3 (DC Output)

The Isolated DUT Output Power is delivered to external loads through the MAIN OUTPUT connectors J1/J10 (Vout+) and J7/J11 (Vout-). See Table 4. Mating connectors are provided.

Table 4: Output Power Connectors

Connector Terminal #	Signal Name
J1/J10	+VOUT
J7/J11	-VOUT

DC Output - Scope Probing Options.

- BNC3 connector labeled Vout Kelvin provides a Kelvin connection for monitoring Vout during testing.
- The output current can be measured using a standard current probe clamped on to one of the output load lines

Capacitor Bank on the Evaluation Board

The test board includes four banks of 1,320 μ F (5,280 μ F total) solid polymer electrolytic output capacitors. The bank capacitors are for good ESR at low temperature and lifetime at high temperature. They are rated from -55 $^{\circ}$ C to 125 $^{\circ}$ C.

Each bank can be individually connected (or disconnected) from the DC Power Output using the two pin jumpers H2, H3, H4 and H5. An LED near each jumper will indicate (when the DUT is enabled) that the corresponding bank is active. Ensure at least one string of the capacitors is active at all times to stabilize the input system both for this converter and downstream power converters.

Additional output capacitance can be attached through the MAIN OUTPUT terminals. Please refer to the applications section of the datasheet for more detailed information on additional capacitance.

http://www.synqor.com/Datasheets/MPFIC-115-3PH-28R-FT-N-S_Datasheet.pdf

Section 5 – Basic Operating Instructions

Attach scope probes, control stimuli as desired.

- 1) Connect the desired load to the DC Output
- 2) Apply the 3-phase input, 115 Vrms (L-N) at J16 on left, using the provided cable assembly. Lamps LI1, LI2, LI3 should light to indicate the presence of hazardous voltages at the input.
- 3) Use Switch S1 in lower right for PFC enable / disable to turn the unit on and off.
- 4) Use Switch S2 in upper right to provide a logic low to turn on Battle Short and disable protection.

The following figures show the AC current and voltage waveforms that should be observed if the 100033-01 board has been configured properly. These waveforms were taken using differential voltage probes (L-N) and isolated current probes.

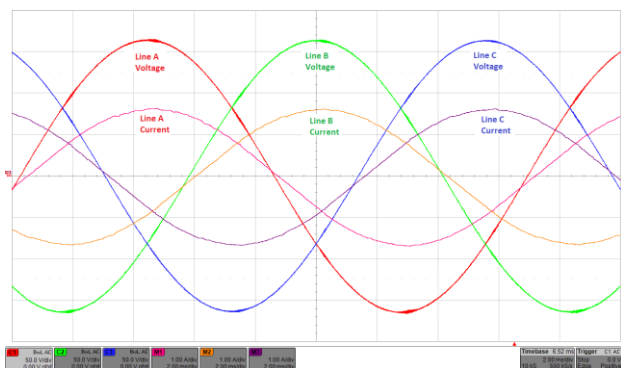

Figure 1 - 60Hz, 50% Load, 2 msec/div
Line Voltage: 50 V/div
Line Current 1 A/div



Figure 2 - 60Hz, Full Load, 5 msec/div
Line Voltage: 50 V/div
Line Current 2 A/div

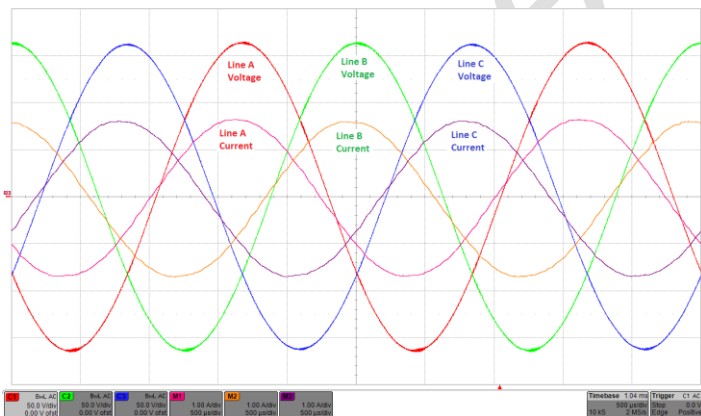

Figure 3 - 400Hz, 50% Load, 0.5 msec/div
Line Voltage: 50 V/div
Line Current 1 A/div

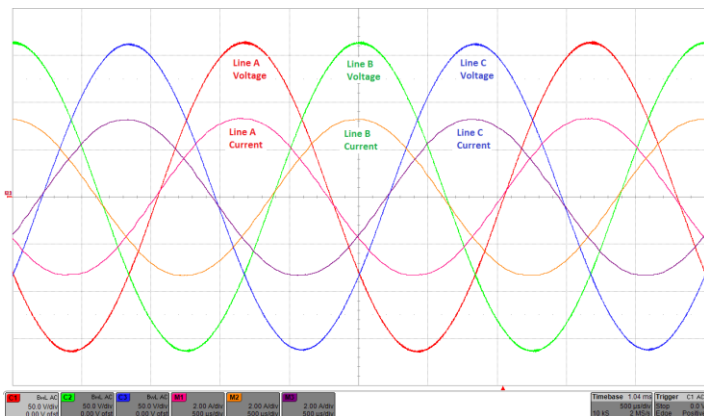

Figure 4 - 400Hz, Full Load, 0.5 msec/div
Line Voltage: 50 V/div
Line Current 2 A/div