

SynQor

Mil-COTS 270V
Full Feature
Recommendations

Mil-COTS 270V Half Brick Full Feature

Application Note

Mil-COTS



Designed and Manufactured in the USA

This application note explains how to implement the features of Full Featured Mil-COTS 270 and 270N Half Brick Converters. Features include active current sharing, clock synchronization, and start-up synchronization. These items are explained in detail and layout suggestions and wiring schemes are presented.

Key Considerations When Using Full Feature Mil-COTS 270V Half Brick Converters

1. The current share pin of the 270V Mil-COTS half brick products is referenced to the primary, and its voltage varies from 0.5V to 3.5V as the converter's output current ranges from zero to full rated load.
2. To force two or more modules to current share the Ishare pins need to be connected together. Care should be taken to minimize the circuit impedance between the IN RTN pins of the different modules. Any voltage mismatch on the IN RTN pins will result in discrepancies in the current share signal measured by the individual converters. This will cause a current miss-match between the converters.
3. When using the current share feature SynQor recommends that the START SYNC pins of all the modules be connected together. Connecting the START SYNC pins together allows all of the modules to start together. This is an important feature for systems that have a total system load that exceeds the load requirement of a single converter. Without this connection, any set of converters attempting to asynchronously start (or re-start) with a load greater than the current limit of a single unit will "hiccup". This "hiccup" mode will continue until one converter attempts to start at the same time as the minimum number of additional units necessary to sustain the load condition.

For example, three 43A 8.0V units starting into an 80A load would require two units to simultaneously attempt a start. The Start Sync pin connection synchronizes these starting attempts and provides a more consistent and reliable start-up sequence.
4. Synchronizing the clock frequencies of the different converters isn't required for parallel operation. All SynQor DC/DC converters have input and output filters that minimize any interactions from mismatches in switching frequencies.
5. If external clock synchronization is required, a clock signal with a frequency in the range of 600 to 650 kHz must be supplied to each converter. The signal on the CLOCK SYNC pin should not exceed 5V amplitude (0 – 5V signal) and should have a 40% to 60% duty cycle. SynQor recommends that the CLOCK SYNC signal be applied prior to power-up of the different converters. Changing the system frequency once the converters are running is not recommended.
6. To avoid input instability a local damping network is recommended at the input power pins of each converter. An instability condition can occur because DC/DC converters appear at their inputs as an incrementally negative resistance load. A detailed application note titled "Input System Instability" is available on the SynQor web site (www.synqor.com) that provides guidelines for selecting the proper input damping network.
(http://www.synqor.com/documents/appnotes/appnt_System_Instability.pdf)
7. Simple paralleling as described above does not provide full system redundancy. Achieving full redundancy requires OR'ing devices which can be Schottky diodes or MOSFETS driven by a suitable circuit. The OR'ing device disconnects the output of the specific converter from the system voltage in the event of a shorted converter output stage. A single converter failure should not result in a system failure. Additionally, a small MOSFET should be added in series with the +SNS line of each converter to disconnect the +SNS line in case of a module failure.

An internal switch disconnects the converter from the Ishare line when a failure occurs, preserving load share functionality. Clock sync and frequency sync functions are not affected by a converter failure and don't need protective external switches.

Key Considerations When Using Full Feature Mil-COTS 270V Half Brick Converters

8. If an EMI filter is used, care should be taken to avoid increasing the circuit impedance between the IN RTN pins of any converters connected for current sharing. SynQor recommends that a single EMI filter be used for each power board. SynQor further recommends if multiple power boards are used that a supplemental current share mechanism be used to force the power boards to share the system load. Due to the increased IN RTN impedance between the power boards, the current share circuitry provided with each Mil-COTS module will not work well when trying to implement load share between physically separate power boards.
9. Load share controllers from TI (UCC39002, UCC3907) could be used to implement load share between multiple power boards. These two load controller chips sense the output current (load current) and adjust the output voltage of the module to force load sharing. In order to reduce the power dissipation on the sense resistor, the output current from a single Mil-COTS converter can be sensed using the UCC39002 load share controller and its output voltage adjusted by driving the TRIM pin voltage. SynQor's recommends adjusting the TRIM pin voltage instead of pulling from the +SNS leads as described in the applications notes of the UCC39002. Since all of the modules in a single power board are forced to current share using the primary side current share feature in the 270V Mil-COTS product, adjusting the current in one of the modules in the power board will force all of the other converters in the power board to share. When using a load share controller like the UCC39002, good results are obtained when the load share controller responds very slowly to any changes in current (suggest having a current share cross over frequency of less than 50 Hz).
10. When using multiple EMI filters as suggested here (one EMI filter per power board), the ON/OFF signal between power boards is no longer referenced to a common voltage. In this case opto couplers should be used to transfer and control the ON/OFF signals to the converters in each power board. The ON/OFF pins between the different converters on a given power board can be connected together as long as independent control of each module is not needed. SynQor recommends a small filter capacitor of 0.01 μF be placed locally between each ON/OFF pin and the IN RTN pin of the respective converter.
11. Similarly the START SYNC and Ishare pins between power boards are no longer referenced to a common reference and therefore these signals should not be connected together between power boards. Trying to implement the START SYNC function between different power boards becomes complex because the START SYNC signal has three states, high, low, and high impedance. The simplest solution would be to sequence the load so that the load is not enabled unless the system bus is present. Implementing a time delay between when the output voltage is enabled and the time the loads are enabled (~ 100 ms) is a good approach.

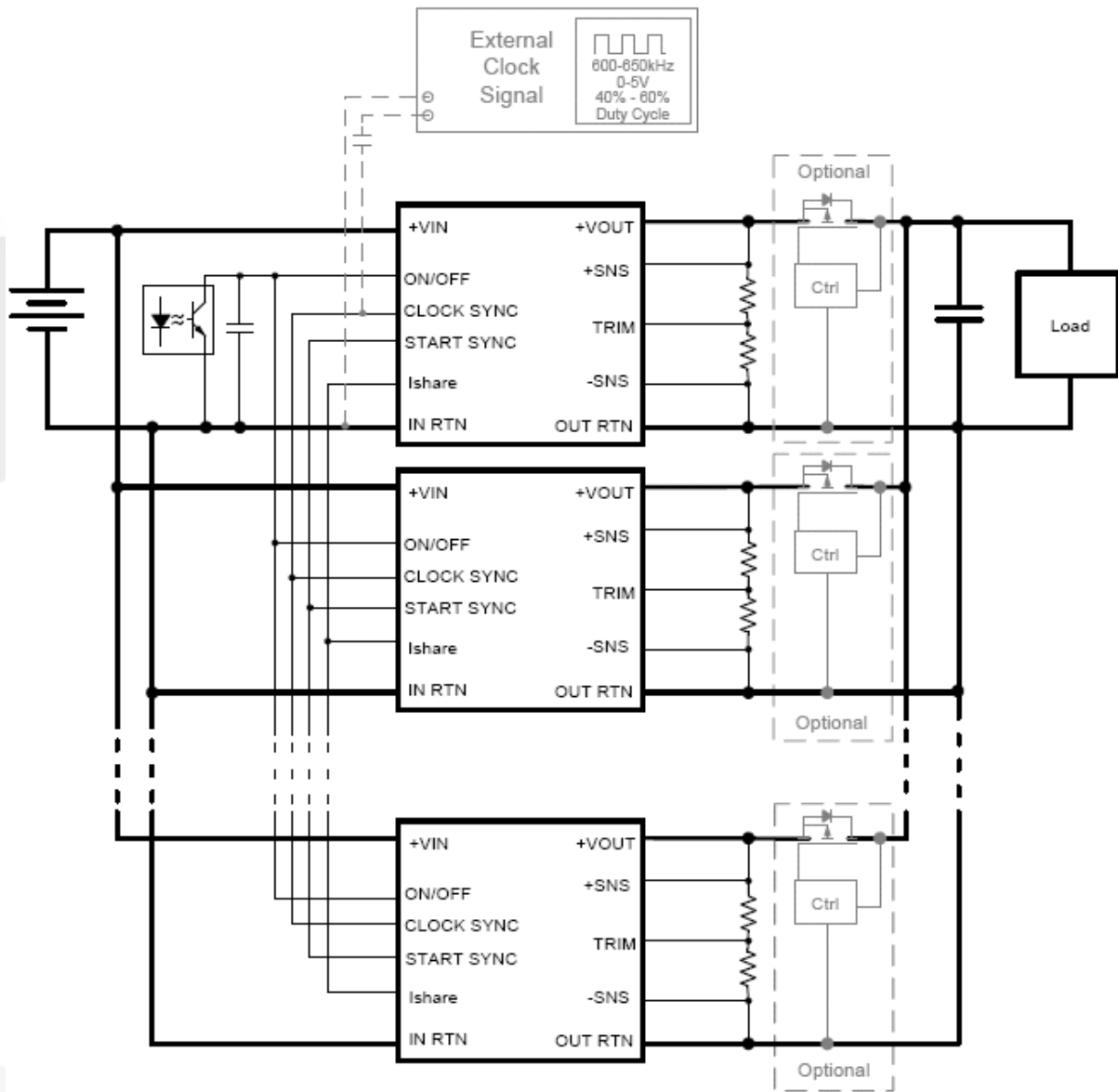

Figure A: *Wiring diagram for multiple Mil-COTS half brick converters.*

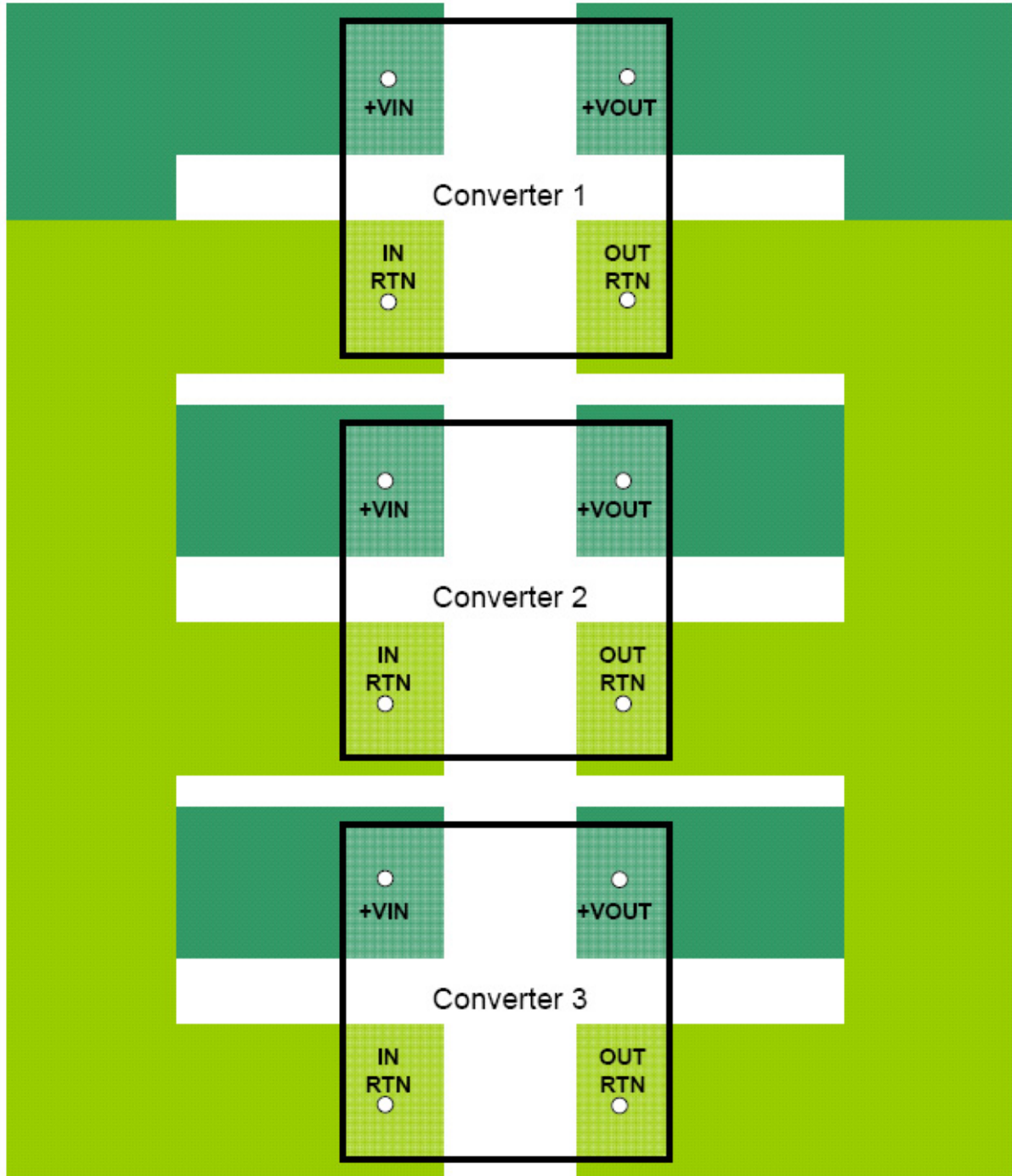

Figure B: Suggested layout for input and output power planes.

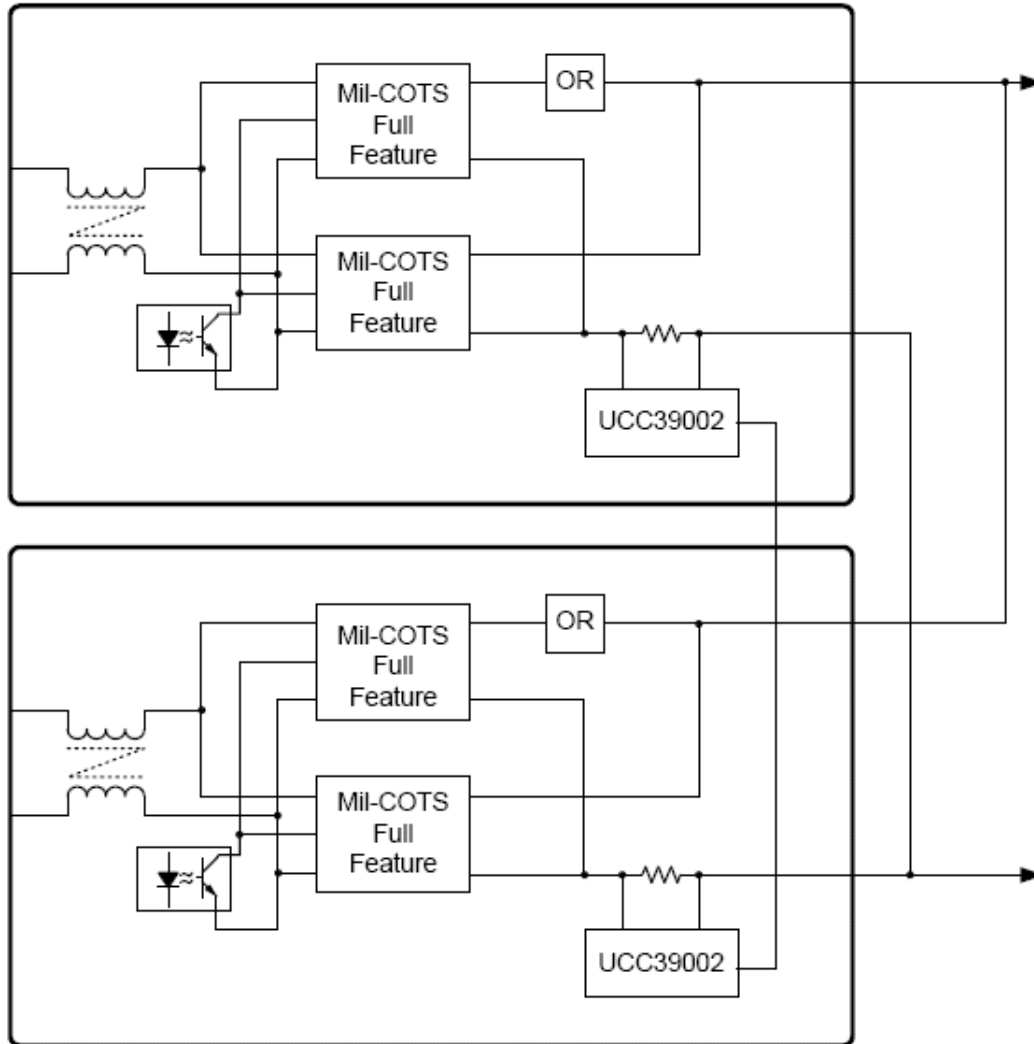
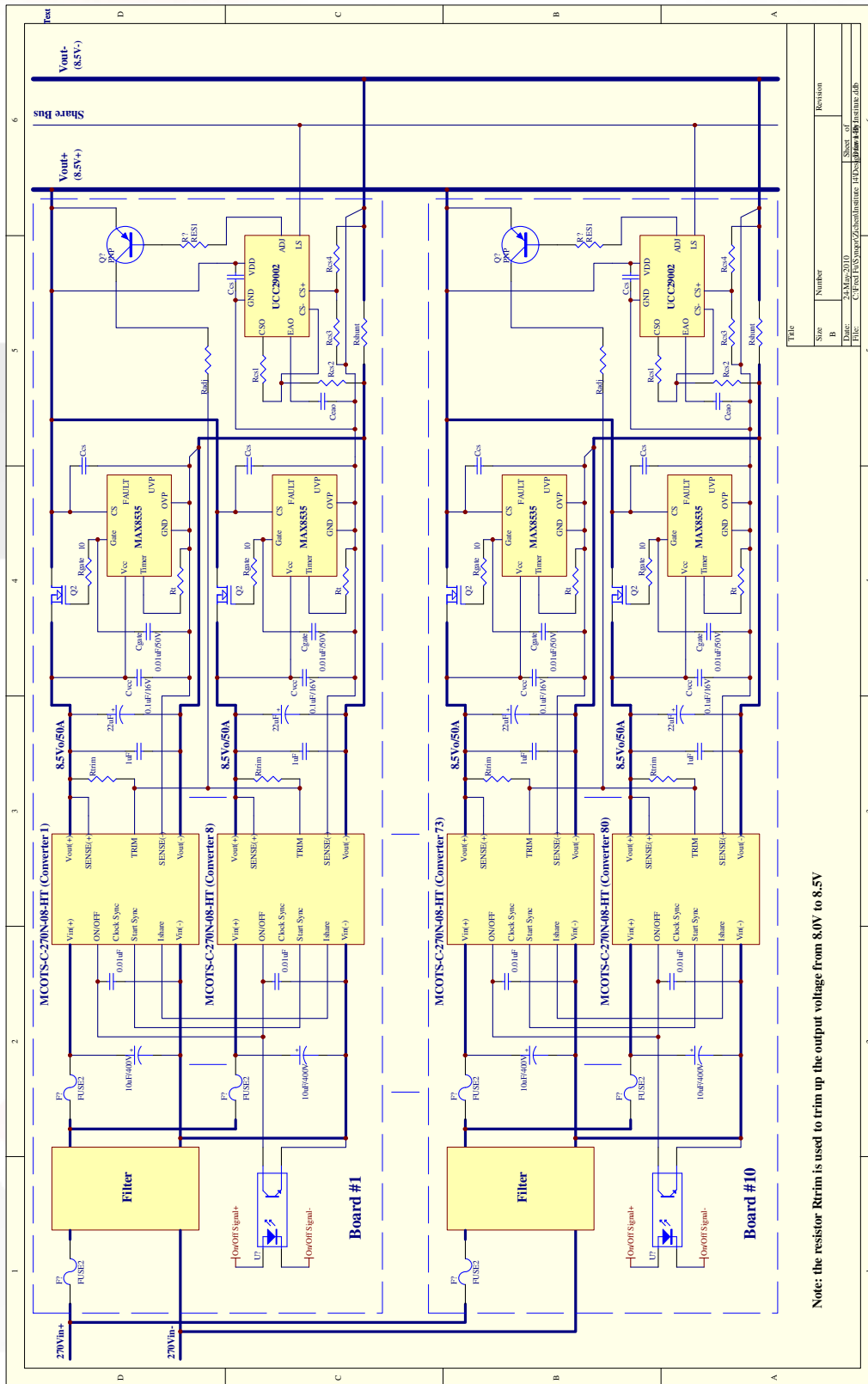

Figure C: Suggested functional interconnect for multiple Mil-COTS half brick converters and multiple boards.

Note: Details of the load-share chip have been omitted for clarity. See UCC39002 datasheet for details.



Note: the resistor Rtrim is used to trim up the output voltage from 8.0V to 8.5V

Figure D: Example schematic for a functional interconnect for multiple Mil-COTS converters and multiple boards.

HALF BRICK PIN LOCATIONS

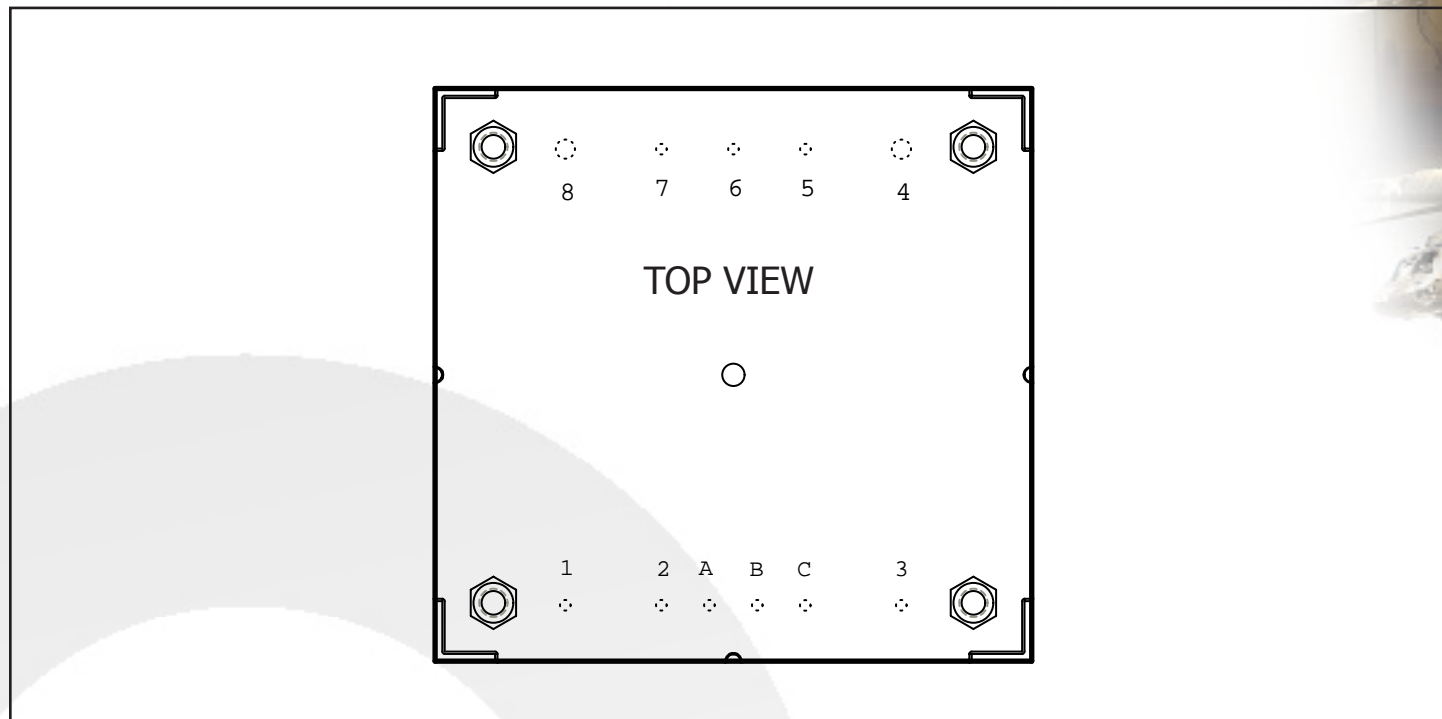

PIN DESIGNATIONS

Pin	Name	Function	Pin	Name	Function
1	+VIN	Positive input voltage	4	OUT RTN	Negative output voltage
2	ON/OFF	TTL input to turn converter on and off, referenced to Vin(-), with internal pull up	5	-SNS	Negative remote sense
A	CLOCK SYNC	Clock synchronization	6	TRIM	Output voltage trim
B	START SYNC	Start-up synchronization	7	+SNS	Positive remote sense
C	Ishare	Active current sharing	8	+VOUT	Positive output voltage
3	IN RTN	Negative input voltage			

Contact SynQor for further information:

Phone: 978-849-0600
Toll Free: 888-567-9596
Fax: 978-849-0602
E-mail: mqnbofae@synqor.com
Web: www.synqor.com
Address: 155 Swanson Road
 Boxborough, MA 01719
 USA