

“Discover a New World without Baseplates”

A Technical White Paper by **SynQor**

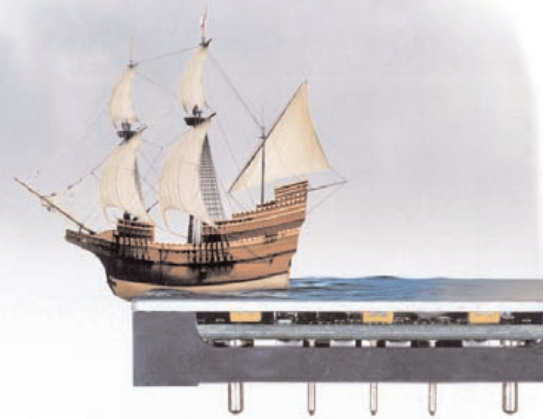

Some still believe in the old world thinking that all dc/dc converters must have baseplates. SynQor's high-efficiency converter design sinks that myth.

Introduction

In the old world of dc/dc converter "bricks", conversion efficiencies were so low that heatsinks were required to keep the converters cool. As a result, converter manufacturers employed a mechanical design that is optimized to transfer the dissipated heat to the heatsink, as shown in Figure 1. An essential element in this design was a metal baseplate to which the heatsink was attached. Although it was a necessary part of the converter, the baseplate added cost, height, weight, and several layers of failure-prone thermal and mechanical connections. In addition to these problems, the baseplate also exacerbated the converter's common-mode noise generation.

Today, the best dc/dc converters use synchronous rectification to improve their conversion efficiency. These new converters are so efficient that they do not require a heatsink. Nevertheless, most of these high efficiency converters still employ a metal baseplate as shown in Figure 2, which acts like an anchor on the converter's performance and design. Significant advantages result when the baseplate is jettisoned, as in SynQor's high efficiency converters, an example of which is shown in Figure 3.

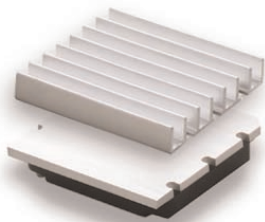

Figure 1: Conventional dc/dc converter with heatsink



Figure 2: High-efficiency base-plated converter



Figure 3: SynQor converter with no heatsink or baseplate

This paper will detail the many advantages of removing the baseplate from dc/dc converters. But let's first review how a converter with a baseplate is typically constructed.

Construction of a Conventional Baseplated Converter

Although the details vary slightly among manufacturers, virtually all converters designed with a baseplate have a tight thermal connection between the baseplate and the power circuit's components (e.g. transistors, rectifiers, transformers, etc.).

The typical approach is to use a "metal board substrate", which is a layer of metal (the baseplate) covered with a thin layer of insulator and a single layer of copper that is patterned according to the power circuit's topology. The power circuit components are then soldered to the copper, providing an electrical connection to the copper layer and a thermal connection (through the thin insulator) to the baseplate.

With only one surface to build on, the metal board substrate does not have enough room for all of the circuitry required in a typical dc/dc converter. Most converters therefore have a second substrate (a printed circuit board) that holds the control circuitry.

With all these layers of material and components inside a conventional dc/dc converter, it is difficult to maintain a 0.5" total thickness. To facilitate this goal, the control circuit substrate usually has cutouts to fit around the taller power components such as the transformer. Also, the baseplate may be thinner in some regions to accommodate the taller components.

The control substrate is sandwiched above the metal board substrate and connected with several extra pins, many of which are not available to the user in the final product. All of these pins, including the input and output power pins, are held in place by solder only. There are no separate mechanical connections to the power substrate to hold the pins in place.

Finally, to help transfer the small, but nevertheless meaningful, amount of dissipated heat from the control substrate to the baseplate, a potting material is used to fill the space between the two.

Figure 4a shows such a baseplated converter upon final assembly. Figure 4b shows the same converter with the outside casing and internal potting material removed. This view shows how the control board and power board substrates are connected in a sandwich configuration.

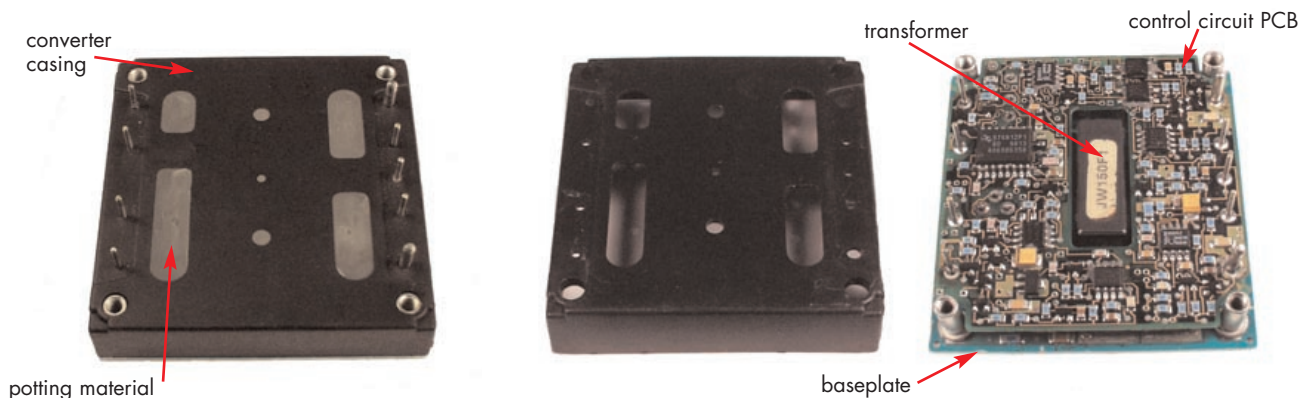

Figure 4a: Conventional dc/dc converter (fully assembled)

Figure 4b: Same converter with potting and casing removed

Figure 4c details the converter with the two substrates separated. This view shows the details of the power substrate and mechanical connection of the pins.

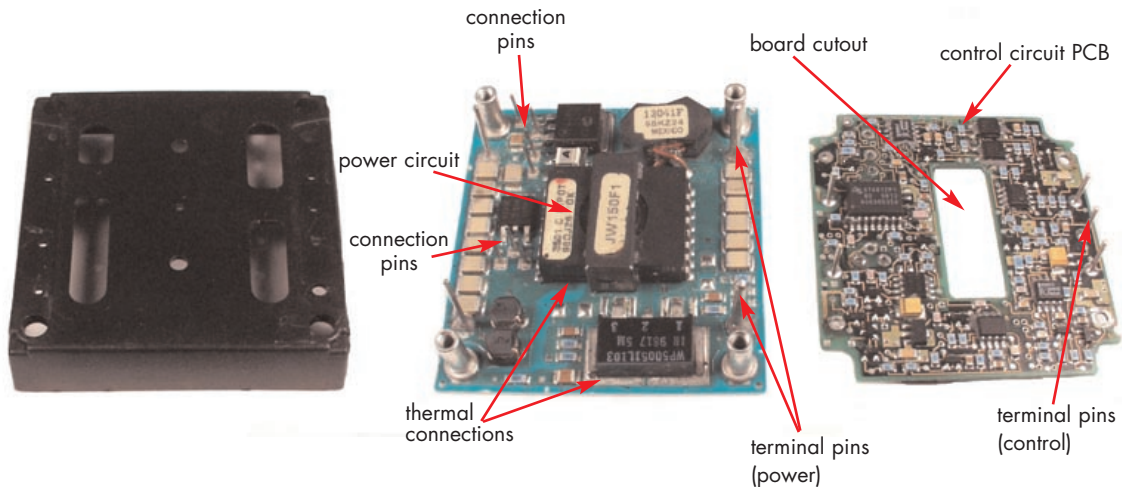

Figure 4c: Same baseplated converter with substrates separated

Over time, there have been slight variations on this typical converter design. Some converters no longer use the potting material. These have been labeled “open-frame” converters because the frame of the converter does allow some limited air to flow through the unit. Other converter designs connect (both mechanically and thermally) the packages of the heat producing components to a simple metal baseplate, but then make the necessary electrical connections on the second PCB substrate by bending the leads of the components. Still others construct the entire converter on a PCB substrate, and then attach a metal baseplate to this substrate in a way that makes a reasonably good thermal contact between the baseplate and the power components.

An “Open Board” DC/DC Converter

Today's leading edge dc/dc converters use synchronous rectifiers (rather than Schottky diodes) to achieve efficiencies greater than 90% for a 3.3V output. With this level of efficiency, the converter dissipates less than half the heat of a Schottky diode based converter that is only 80% efficient. As a result, there is no longer a need to attach a heatsink to the converter to keep its components cool. With no heatsink, there is no need to provide a baseplate to which the heatsink would normally be attached. Removing this design limitation permits the use of an "open-board" construction technique, like the one used by SynQor (shown in Fig. 3).

With this open-board construction there is only a single substrate, a PCB (shown in Fig. 5). The board has many layers of extra thick copper, depending on the current rating of the converter, but it is otherwise a normal PCB. All of the converter's power and control circuit components are surface mounted to this PCB on both the top and bottom sides using a standard SMT process.

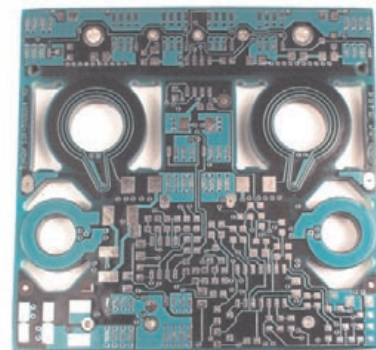

Figure 5: Single PCB substrate used in SynQor converters

In the SynQor converter, the windings for the magnetic components (transformers and inductors) are also formed in the PCB. Ferrite cores are then inserted through cutouts in the PCB and epoxied together to the PCB to complete the construction of the magnetic components.

The pins for the SynQor converter are press-fit into pre-set holes to give a solid mechanical connection to the PCB. The polygonal cross-sectional shape of the inserted portion of the pin provides a path for solder to flow down the pin and make an excellent electrical and mechanical connection between the pin and the PCB's via.

Notice that the pins of SynQor's converters have flanges at their bottom ends. These flanges provide a "stand-off" function that keeps the converter's components at least 40 mils above the load board. They do so while taking up the minimum amount of space on the converter's substrate and on the load board. The total height of the SynQor converter is only 0.4 inches. However, only a few components reach this maximum height while most of the converter is even lower. Figure 7 shows a cross section comparison of a typical baseplated converter versus the SynQor open-board converter.

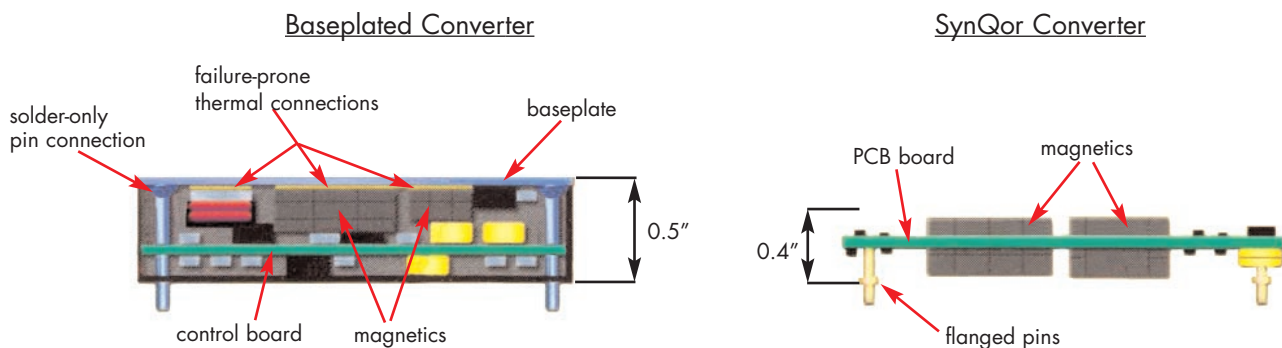

Figure 7: Cross-section comparison of conventional converter and SynQor "open-board", no baseplate converter showing differences in construction techniques.

Advantages of Open-Board Construction with No Baseplate

Several advantages result from an open-board, no-baseplate construction approach:

1. Simpler construction
2. Higher reliability
3. Lower height
4. Better flow of cooling air
5. Reduced common-mode EMI generation
6. Lower weight
7. Easier to use

Each of these advantages is discussed in more detail below.

Simpler Construction

SynQor's open-board converters are built on an SMT line where standard surface mount components are placed on a PCB by conventional pick-and-place machines. Only the magnetic elements require special handling. SynQor has further simplified this process by incorporating the windings into the PCB. The magnetic cores are then added with a simple, semi-automated process that epoxies the core pieces to each other and to the PCB. All of the cores are identical for each converter size (half-brick or quarter-brick), independent of the output voltage or the rated output current.

One advantage of this simplicity is the ease with which SynQor can expand its manufacturing capacity to meet the growth of today's dc/dc converter marketplace. No special machinery or process controls are needed. SynQor can also easily take advantage of the manufacturing capacity offered by contract manufacturers and offer quicker response time to its customers.

In addition, the simpler construction means there is far less chance of problems occurring during manufacturing. There are no large-area solder joints to watch for "voids", no pins that are held in place only by solder, no potting material that may lift-up or break a component, and no thermal pads to be pressed together. In the final product, all of the components in a SynQor dc/dc converter are available for visual inspection, where most (if not all) of the components in a baseplated converter are hidden.

Higher Reliability

A dc/dc converter constructed on a metal board substrate has many failure prone mechanical/thermal connections that contribute significantly to its lack of reliability compared to the load's digital circuitry.

For instance, as mentioned above, every power transistor and diode in such a converter comes in a package with a metal header that is soldered to copper traces on the metal board substrate. Typically, the area of these headers is one square centimeter, or larger. It is not easy to get a perfect solder joint under such a large area. In some percentage of the population, these solder joints will have voids. A void (or bubble) in a solder joint under a header makes the thermal connection of the header to the baseplate much more resistive (see Fig. 7). Under full power operation, the semiconductor device in such a poorly mounted package may therefore reach a temperature 20-30°C higher than it would have been in a perfect solder joint. The long-term reliability of that part is therefore significantly reduced.

Another source of mechanical failure in a typical baseplated converter are the pins used for power and control. As stated earlier, in a typical baseplated converter there are no separate mechanical connections to the power substrate to hold the pins firmly in place. All the pins are held in place by solder only (see Fig. 7). By contrast the pins for the SynQor converter are press-fit into pre-set holes to give a solid mechanical connection to the PCB. The cross-sectional shape of the inserted portion of the pin provides a path for solder to flow down the pin and make an excellent electrical and mechanical connection between the pin and the PCB's via.

Reliability is further compromised in most baseplated converters by the potting material used to help transfer the dissipated heat from the internal components to the baseplate. The process of filling and hardening of this compound can cause some parts to be lifted or pushed out of place on the converter's PCB boards. This potting also experiences thermal expansion and contraction as the converter heats up and cools down during normal operation. This pushing and pulling motion can cause undue stress on internal components and reduce their long-term reliability. With SynQor's converters there is no potting material to cause disruption of components or subject them to unwanted stresses.

Finally, potting materials preclude the ability to perform a proper visual inspection of the converter. Even with "open-frame" converters that use no potting materials, a visual assessment is extremely difficult since the baseplate hides nearly all of the internal components. With SynQor's "open-board" converters there is no potting material or baseplate to impede a thorough visual inspection by the manufacturer or end-user. This unique attribute facilitates quality control and failure diagnostics.

Lower Height

Typical brick converters with a baseplate construction are 0.5" high. SynQor's open-board, no-baseplate converters are only 0.4" high. The difference may appear to be slight but often the dc/dc converter is the tallest component on a load board. A small height savings can mean the difference between using a 0.6" board-to-board pitch versus a 0.9" pitch. In the highly competitive telecom and datacom markets, that could mean adding an extra 10 load boards on a standard 19" wide rack-mounted product. The difference is magnified when one considers that most conventional dc/dc converters still require a heatsink to operate at or near full rated load. As a result, the converter module with heatsink is typically a full 1.0" or more in height. The SynQor converter at 0.4" can provide significant height savings for engineers looking to create a tighter board pitch in their end product (see Figure 8). Meanwhile the SynQor converter can still produce more power output than a baseplated converter with an attached heatsink. (for additional information, read SynQor's white paper "Get the Heatsink Off Your Back")

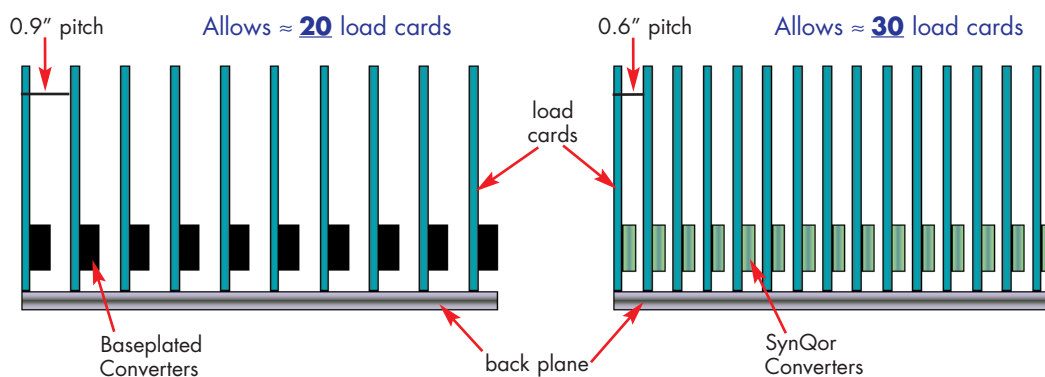

Figure 8: Lower height on SynQor converter allows tighter card pitch and more total cards in rack. (one-half of a standard 19" rack is represented in each image)

Better Flow of Cooling Air

Another major benefit of the open-board, no-baseplate converter is its effect on cooling airflow. The highest components on the SynQor converter measure 0.4" but this tallest height only represents a small portion of the total converter board area. Many of the components are much lower in profile, similar to a city skyline with buildings of various heights. With a baseplated converter the entire structure is 0.5", meaning the entire city skyline is comprised of the tallest building. This has a detrimental impact on cooling airflow as it hits the front end of the converter and is diverted well above and around the unit, creating a large boundary layer above the baseplate. With the SynQor unit, the air hits the lower profile front edge of the converter and hugs the top of the unit, creating a smaller boundary layer and allowing cooling air to more effectively carry heat away from the module (see Fig. 9).

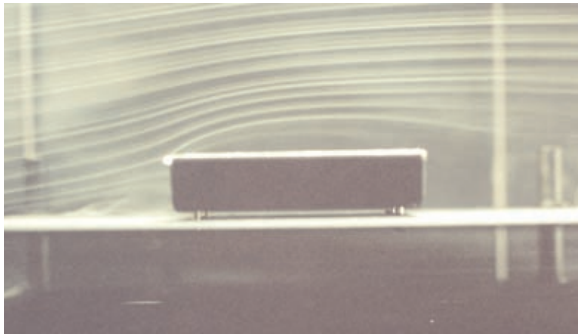

Figure 9a: Airflow over baseplated converter showing large boundary layer



Figure 9b: Airflow over SynQor converter showing small boundary layer

Figure 9 represents a typical test set-up when evaluating the thermal performance of any converter. In this situation there is infinite space above the converter. However, this is not indicative of a real-life application. In most cases there is limited space between the top of the converter and the back of the next load board in series. Figure 10 illustrates this set-up, showing a side view of each converter with a 0.7" high face to face spacing. With this tighter card pitch the baseplated converter allows only 0.2" between the baseplate and the next load board. The limited space above the baseplate causes increased pressure and forces the air to move around the converter in a very disruptive pattern (Fig. 11 will show this in even greater detail).

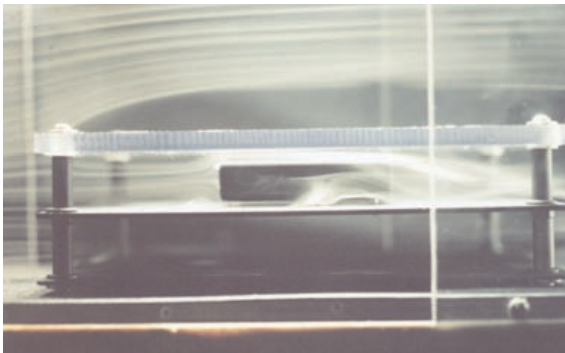

Figure 10a: Airflow into conventional converter showing disruption of airflow with 0.7" card spacing

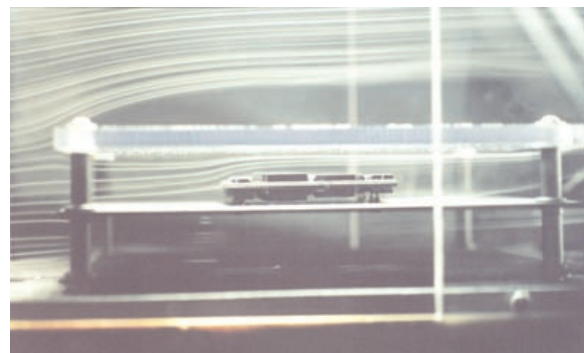

Figure 10b: Airflow into SynQor converter showing unimpeded flow of air with 0.7" card spacing

The SynQor converter allows at least 0.3" between its tallest components and the next load board and significantly more space above its smaller components. This lower profile allows the air to flow smoothly over the converter, instead of being diverted around the converter. As a result, the height of the boundary layer (Fig. 9 vs. Fig. 10) is actually reduced and cooling of the unit improved.

A top view with the same 0.7" board spacing (Fig. 11a) shows that the air is completely diverted around the baseplated converter. Therefore, virtually no cooling air reaches the baseplate to carry the dissipated heat from the unit. In the same configuration with the SynQor converter (Fig. 11b), the air passes directly over the unit allowing cooling air to reach components on the top and bottom of the converter board.

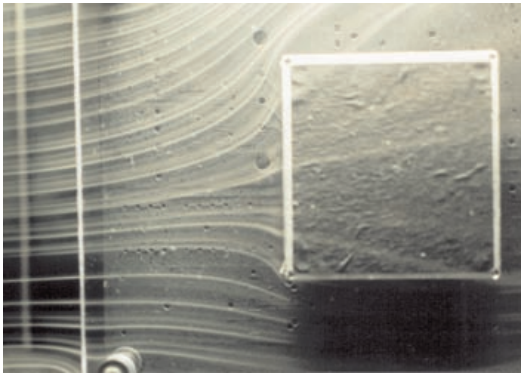

Figure 11a: *Airflow over conventional converter showing blockage and diversion of airflow above and around the converter*



Figure 11b: *Airflow over SynQor converter showing free flow of air over the converter*

The limited disruption of the airflow also benefits the components on the load board that are "down stream" from the converter. Since air is not blocked, these components receive more cooling air than if they were obstructed by a baseplated converter. This is especially true when there is a tight board pitch and the space between the top of the converter is very close to the next board in series (see Fig. 10).

Figures 9 to 11 demonstrate that the low-profile SynQor converter provides better airflow and cooling properties than a baseplated converter, with or without a tight board pitch. With a wide board pitch, the SynQor converter has a smaller boundary layer and limited disruption of airflow. In the case of a tight board pitch the SynQor converter actually reduces its boundary layer and improves its cooling properties while the baseplated converter gets relatively worse. This airflow analysis reveals that real-life performance of a baseplated dc/dc converter can differ dramatically from test results listed in a specification sheet. By contrast, SynQor provides detailed thermal profiles of its converters over temperature, airflow speed and orientation so that one can determine true output power performance and accurate component temperatures.

Reduced Common-Mode EMI

An isolated dc/dc converter creates common-mode EMI because differential ac waveforms created by circuitry on one side of the isolation barrier couple to the circuitry of the other side of the barrier. A

baseplate accentuates this coupling, as explained in detail below. Removing the baseplate can significantly reduce the converter's common-mode EMI, particularly in the troublesome 20-50 MHz frequency range.

Consider a MOSFET power transistor used to implement the input side circuitry of an isolated dc/dc converter that has a baseplate. As this transistor turns on and off, its drain-source voltage changes very quickly from perhaps 100 volts to nearly zero volts and back again. Each transition is typically followed by a parasitic "ringing" where the voltage waveform oscillates in the 20-50 MHz range for several cycles.

The drain of this transistor is both thermally and electrically connected to the metal header of the transistor's package. This header is, in turn, thermally connected to the converter's baseplate through a thin layer of electrically insulating material so that the heat dissipated by the transistor can get to the baseplate, but the baseplate can still be connected to chassis ground.

Although the drain of the transistor is not directly connected to the baseplate, it is very tightly coupled to it capacitively through the thin insulating layer. With a metal board substrate, this layer may only be 10-15 μm thick, and so this capacitor is relatively large (e.g. 300 pF). See Figure 12 for a schematic diagram of this connection.

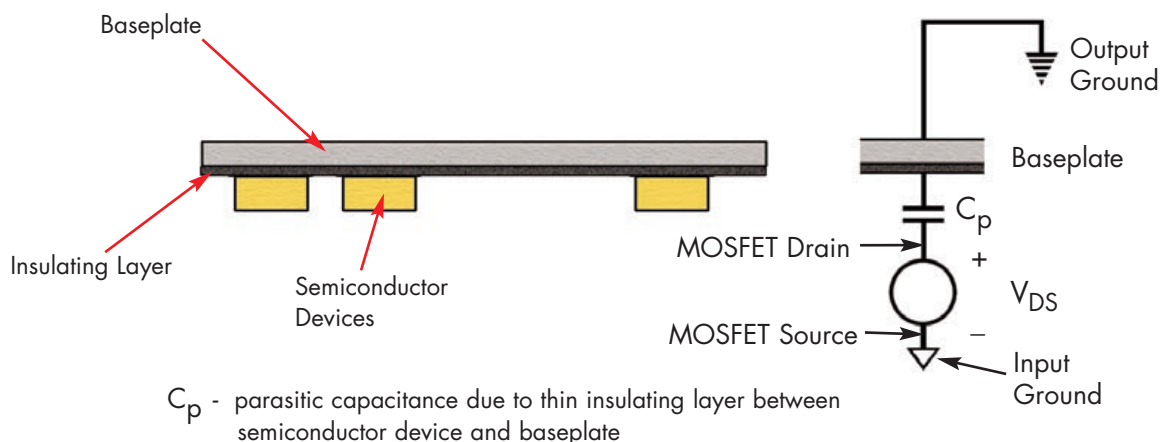

Figure 12: Traditional physical design for baseplated dc/dc modules.

The capacitive connection provides a path for common-mode currents to flow from input ground to output ground. The transistor's differential drain voltage, relative to the ground of the input side of the converter, is applied to one side of this parasitic capacitor. The other side of the capacitor is connected to the baseplate, which is usually connected to the ground of the output side of the converter. As such, a common-mode circuit is formed with the transistor's drain voltage as the driving force and the parasitic capacitor as a series impedance.

How much common-mode current flows depends on the impedance of the rest of the common-mode circuit formed when the output side ground is eventually coupled back to the input side ground, typically through an EMI filter. However, the parasitic capacitor connecting the drain to the baseplate is so large that it is seldom a limiter to how much common-mode current that will flow. For instance, at 30 MHz, 300 pF capacitor has an impedance of less than 20Ω whereas the impedance of a typical common-

mode choke is greater than 20kΩ at this frequency.

In an open-board converter without a baseplate, there is still an input side transistor drain voltage that is undergoing fast and large transients. The difference is that it is not tightly coupled to a baseplate that is connected to the output ground. Instead, the drain node is typically many centimeters away from any output side circuitry, and as such the capacitive coupling to the output ground is very small (e.g. 3 pF). The common-mode currents that flow, for a given EMI filter, are therefore much smaller.

Thought of another way, less common-mode filtering is required for a converter that does not have a baseplate compared to one that does. Typically, the low common-mode EMI levels that would only be achieved with two stages of common-mode chokes in a baseplated converter can instead be achieved with a single stage of a common-mode choke in a converter without a baseplate.

Lower Weight

SynQor's half-brick sized converter weighs less than 2 ounces. In comparison, a similarly sized baseplated converter with potting weighs 3-4 ounces (and if a 0.5" high heatsink is required, the total weight goes up to 4-5 ounces). Often several such converters are required on a single load board, so the total weight savings can be substantial.

Most applications are not sensitive to the dead weight of a converter, but they are affected by the converter's mass when it is subjected to acceleration. The digital load boards on which converters are placed are often quite large (e.g. 20" x 30"), and they are therefore relatively flexible. When these boards are mechanically shocked or vibrated (for instance, during shipment), the heavy mass of conventional dc/dc converters will tend to bend the boards. This bending can cause damage to the components mounted on the board, or to the solder joints that connect them to the board. With a lighter converter, this problem is minimized. In fact, an open-board converter without a heatsink has approximately the same weight per unit area as does the digital load board itself.

Easier to Use

All the advantages described above translate into a converter that is much easier to implement and operate in both new and existing designs. The SynQor high efficiency converters eliminate the need for attached heatsinks. Freedom from this constraint allows significant advantages in height, weight, cost and application effort. Once the heatsink is eliminated, the need for a metal baseplate disappears. Removing the baseplate from the converter design allows a greatly simplified construction technique that eliminates the failure prone thermal connections found in most dc/dc converters. The simple SMT construction allows quick capacity expansion, second sourcing of manufacturing and final visual inspection for higher quality.

Physical differences in the converter provides a lower overall height and weight which permit a tighter board pitch as well as reduced effects of shock and vibration and better airflow across the converter. With no baseplate the common-mode EMI is reduced significantly, allowing less common-mode filtering and easier implementation.

Conclusion

If the old-world, flat converter technology is limiting your horizons, it's time to explore the new shape of high efficiency, no-baseplate converters. SynQor's open-board dc/dc converters have eliminated all the non-essential construction materials that were required by conventional converters. SynQor's revolutionary design offers many important advantages with no cost penalty.

Baseplated converters have served the industry well for nearly 15 years but their performance limitations have made this technology nearly obsolete. Don't sink your next design with an old style converter. Chart a new course with SynQor and let the high-efficiency, no-baseplate converters put the wind back in your sails.



Don't let an old style baseplated dc/dc converter sink your next design. Expand your horizons with SynQor's line of high-efficiency, no-baseplate converters.

SynQor

Advancing The Power Curve

155 Swanson Rd., Boxboro, MA 01719

Phone: 978-849-0600

Toll Free: 888-567-9596

Fax: 978-849-0602

Web: www.synqor.com

e-mail: sales@synqor.com

QMS: 066-0000008-PDF

Rev: 1

